



## CFDSA2VM07/ CFDSA2VM11

### Features:

- Designed specifically for the Toughpad FZ-A2
- Accommodates FZ-A2 with large configuration options, handstraps and cases
- Pinch lock mechanism for ease of use
- Lock accessible with both hands
- VESA 75mm mounting pattern
- Composite ABS construction for weight saving and durability
- Docking mechanism tested to 30,000 cycles (not limited to)
- Designed and tested to MIL-STD-810G test criteria
- 1 year standard warranty (pick-up and return)
- Extended Warranty and Accidental Damage coverage available

## EXPANDED VEHICLE DOCK FOR TOUGHPAD FZ-A2

A rugged, expanded vehicle dock for the Toughpad FZ-A2, specially designed by Panasonic to accommodate the FZ-A2 tablet with large configuration options, cases and hand straps. The ergonomic pinch lock mechanism and slam latch allow easy lock and release operation with both hands, while the rugged, impact-resistant casing allows this dock to be both durable and lightweight.



# EXPANDED VEHICLE DOCK FOR TOUGHPAD FZ-A2

Model Number :	CF-CDSA2VM07	CF-CDSA2VM11
Antenna Pass-Through	Yes	No
Lock Type	Keyed Alike	Keyed Alike
Power Input	DC-16V	
LAN	1 X	
USB	2 x USB 2.0	
Serial	-	
VGA	-	
HDMI	-	
<b>Dimensions</b>		
Width	11.7"	
Height	10.1"	
Depth	4.62"	
Weight	TBC	
Warranty	1 year standard warranty, extended options available	
Configurations supported :	With handstraps, case, or other large configuration options	
Non Electronic Version?	No	Yes

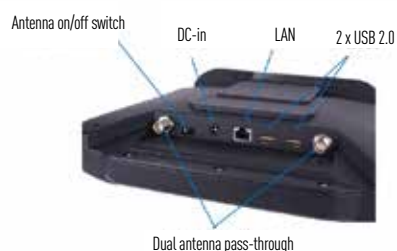
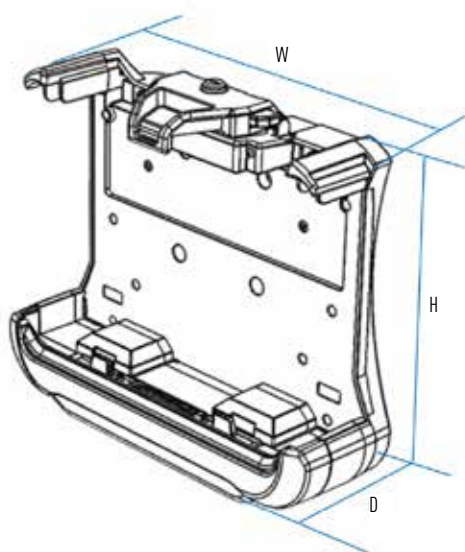

## CERTIFICATIONS AND TESTING:

- Tested to MIL-STD-810G test criteria
- Europe: CE & Automotive CE (EN50498) (Covers E-Mark); Product Safety (EN60950); UNECE Reg. 17 impact Test (Tested under controlled conditions at Horiba MIRA but does not constitute type approval);
- USA: FCC, Product Safety (UL60950-1), SAE J1455 (Covered in UNECE Reg 17 Impact Test)
- Australia / New Zealand: RCM
- Japan: VCCI
- Rest of World: CB Certification (Product Safety IEC60950-1)

**1.866.413.3099**

**business.panasonic.ca**

Panasonic is constantly enhancing product specifications and accessories. Specifications subject to change without notice. Trademarks are property of their respective owners.  
© 2016 Panasonic Corporation of North America. All rights reserved. Toughpad FZ-A2 Expanded\_Vehicle\_Dock\_Spec\_Sheet\_10/06/2016

**TOUGHBOOK**