

Service Manual

Air Conditioner

Indoor Unit
CS-ME5SD3UA
CS-ME7SD3UA

Destination
USA

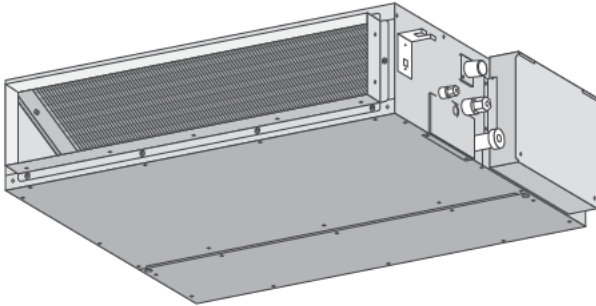

Please file and use this manual together with the service manual for Model No. CU-2E18SBU, Order No. PAPAMY1604017CE.

WARNING

This service information is designed for experienced repair technicians only and is not designed for use by the general public. It does not contain warnings or cautions to advise non-technical individuals of potential dangers in attempting to service a product. Products powered by electricity should be serviced or repaired only by experienced professional technicians. Any attempt to service or repair the product or products dealt with in this service information by anyone else could result in serious injury or death.

IMPORTANT SAFETY NOTICE

There are special components used in this equipment which are important for safety. These parts are marked by  in the Schematic Diagrams, Circuit Board Diagrams, Exploded Views and Replacement Parts List. It is essential that these critical parts should be replaced with manufacturer's specified parts to prevent shock, fire or other hazards. Do not modify the original design without permission of manufacturer.

PRECAUTION OF LOW TEMPERATURE



In order to avoid frostbite, be assured of no refrigerant leakage during the installation or repairing of refrigerant circuit.

TABLE OF CONTENTS



	PAGE		PAGE
1. Safety Precautions	3	15.1 Indoor Electronic Controller, Blower Fan, Fan Motor & Drain Motor Removal Procedure.	68
2. Specifications	5	16. Technical Data	71
3. Features	9	16.1 Fan Performance.....	71
4. Location of Controls and Components	10	17. Exploded View and Replacement Parts List	73
4.1 Indoor Unit.....	10	17.1 Indoor Unit.....	73
4.2 Remote Control	10		
5. Dimensions	11		
5.1 Indoor Unit.....	11		
6. Refrigeration Cycle Diagram	12		
6.1 Indoor Unit.....	12		
7. Block Diagram	13		
7.1 Indoor Unit.....	13		
8. Wiring Connection Diagram	14		
8.1 Indoor Unit.....	14		
9. Electronic Circuit Diagram	15		
9.1 Indoor Unit.....	15		
10. Printed Circuit Board	16		
10.1 Indoor Unit.....	16		
11. Installation Instruction	17		
11.1 Indoor Unit.....	18		
12. Operation and Control	26		
12.1 Basic Function.....	26		
12.2 Quiet Operation (Cooling Mode/Cooling Area of Soft Dry Mode).....	29		
12.3 Powerful Mode Operation.....	30		
12.4 Timer Control.....	30		
12.5 Auto Restart Control.....	30		
12.6 Indication Panel.....	30		
12.7 Electric Heater Control 1	31		
12.8 Electric Heater Control 2	32		
13. Servicing Mode	33		
13.1 TEST RUN OPERATION (FOR PUMP DOWN/SERVICING PURPOSE)	33		
13.2 Auto OFF/ON Button	34		
13.3 Remote Controller Room Temperature Thermoshift Control	35		
14. Troubleshooting Guide	39		
14.1 Refrigeration Cycle System.....	39		
14.2 Relationship Between the Condition of the Air Conditioner and Pressure and Electric Current.....	40		
14.3 Breakdown Self Diagnosis Function.....	41		
14.4 Error Codes Table	42		
14.5 Self-diagnosis Method	44		
15. Disassembly and Assembly Instructions	68		

1. Safety Precautions











- Read the following "SAFETY PRECAUTIONS" carefully before installation.
- Electrical work must be installed by a licensed electrician. Be sure to use the correct rating of the power plug and main circuit for the model to be installed.
- The caution items stated here must be followed because these important contents are related to safety. The meaning of each indication used is as below. Incorrect installation due to ignoring of the instruction will cause harm or damage, and the seriousness is classified by the following indications.

 WARNING	This indication shows the possibility of causing death or serious injury.
 CAUTION	This indication shows the possibility of causing injury or damage to properties only.

- The items to be followed are classified by the symbols:





	Symbol with white background denotes item that is PROHIBITED.
	Symbol with dark background denotes item that must be carried out.

- Carry out test running to confirm that no abnormality occurs after the installation. Then, explain to user the operation, care and maintenance as stated in instructions. Please remind the customer to keep the operating instructions for future reference.

 WARNING	
1.	Do not install outdoor unit near handrail of veranda. When installing air-conditioner unit on veranda of a high rise building, child may climb up to outdoor unit and cross over the handrail causing an accident. 
2.	Do not use unspecified cord, modified cord, joint cord or extension cord for power supply cord. Do not share the single outlet with other electrical appliances. Poor contact, poor insulation or over current will cause electrical shock or fire. 
3.	Do not tie up the power supply cord into a bundle by band. Abnormal temperature rise on power supply cord may happen. 
4.	Do not insert your fingers or other objects into the unit, high speed rotating fan may cause injury.  
5.	Do not sit or step on the unit, you may fall down accidentally.  
6.	Keep plastic bag (packaging material) away from small children, it may cling to nose and mouth and prevent breathing. 
7.	When installing or relocating air conditioner, do not let any substance other than the specified refrigerant, eg. air etc mix into refrigeration cycle (piping). Mixing of air etc will cause abnormal high pressure in refrigeration cycle and result in explosion, injury etc. 
8.	Do not add or replace refrigerant other than specified type. It may cause product damage, burst and injury etc. 
9.	<ul style="list-style-type: none"> • For R410A model, use piping, flare nut and tools which is specified for R410A refrigerant. Using of existing (R22) piping, flare nut and tools may cause abnormally high pressure in the refrigerant cycle (piping), and possibly result in explosion and injury. • Thickness for copper pipes used with R410A must be more than 1/32" (0.8 mm). Never use copper pipes thinner than 1/32" (0.8 mm). • It is desirable that the amount of residual oil less than 0.0008 oz/ft (40 mg/10 m).
10.	Engage authorized dealer or specialist for installation. If installation done by the user is incorrect, it will cause water leakage, electrical shock or fire.
11.	Install according to this installation instructions strictly. If installation is defective, it will cause water leakage, electrical shock or fire.
12.	Use the attached accessories parts and specified parts for installation. Otherwise, it will cause the set to fall, water leakage, fire or electrical shock.
13.	Install at a strong and firm location which is able to withstand the set's weight. If the strength is not enough or installation is not properly done, the set will drop and cause injury.
14.	For installation work, follow all electrical, building, plumbing, local codes, regulations and these installation instructions. If electrical circuit capacity is not enough or a defect is found in electrical work, it will cause electrical shock or fire.
15.	Do not use spliced wires for indoor/outdoor connection cable. Use the specified indoor/outdoor connection cable, refer to instruction CONNECT THE CABLE TO THE INDOOR UNIT and connect tightly for indoor/outdoor connection. Clamp the cable so that no external force will have impact on the terminal. If connection or fixing is not perfect, it will cause heat-up or fire at the connection.
16.	Wire routing must be properly arranged so that control board cover is fixed properly. If control board cover is not fixed perfectly, it will cause fire or electrical shock.
17.	This equipment must installed with an Earth Leakage Circuit Breaker (ELCB) or Ground Fault Current Interrupter (GFCI) or Appliance Leakage Current Interrupter (ALCI) that has been certified by an NRTL Certified Testing Agency and that is suitable for the voltages and amperages involved. Otherwise, it may cause electrical shock and fire in case of equipment breakdown.

18.	During installation, install the refrigerant piping properly before running the compressor. Operation of compressor without fixing refrigeration piping and valves at opened condition will cause suck-in of air, abnormal high pressure in refrigeration cycle and result in explosion, injury etc.
19.	During pump down operation, stop the compressor before removing the refrigeration piping. Removal of refrigeration piping while compressor is operating and valves are opened will cause suck-in of air, abnormal high pressure in refrigeration cycle and result in explosion, injury etc.
20.	Tighten the flare nut with torque wrench according to specified method. If the flare nut is over-tightened, after a long period, the flare may break and cause refrigerant gas leakage.
21.	After completion of installation, confirm there is no leakage of refrigerant gas. It may generate toxic gas when the refrigerant comes into contact with fire.
22.	Ventilate if there is refrigerant gas leakage during operation. It may cause toxic gas when the refrigerant comes into contact with fire.
23.	This equipment must be properly earthed. Earth line must not be connected to gas pipe, water pipe, earth of lightning rod and telephone. Otherwise, it may cause electrical shock in case of equipment breakdown or insulation breakdown.

 **CAUTION**

1.	Do not install the unit at place where leakage of flammable gas may occur. In case gas leaks and accumulates at surrounding of the unit, it may cause fire.	
2.	Do not release refrigerant during piping work for installation, re-installation and during repairing a refrigeration parts. Take care of the liquid refrigerant, it may cause frostbite.	
3.	Do not install this appliance in a laundry room or other location where water may drip from the ceiling, etc.	
4.	Do not touch the sharp aluminium fin, sharp parts may cause injury. 	
5.	Carry out drainage piping as mentioned in installation instructions. If drainage is not perfect, water may enter the room and damage the furniture.	
6.	Select an installation location which is easy for maintenance.	
7.	Installation work. It may take two people to carry out the installation work.	

2. Specifications

Model		Indoor		CS-ME5SD3UA				
		Outdoor		CU-2E18SBU				
Performance Test Condition				AHRI				
Power Supply		Phase, Hz		Single, 60				
		V		208		230		
		Min.	Mid.	Max.	Min.	Mid.	Max.	
Cooling	Capacity	kW	1.32	1.62	2.30	1.32	1.62	2.30
		BTU/h	4400	5500	7800	4400	5500	7800
	Running Current	A	-	2.3	-	-	2.0	-
	Input Power	W	250	400	640	250	400	640
	EER	W/W	5.20	4.05	3.59	5.20	4.05	3.20
		Btu/hW	17.60	13.75	12.20	17.60	13.75	12.20
	Indoor Noise (H / L)	dB-A	35 / 28			35 / 28		
Power Level dB		51 / -			51 / -			
Heating	Capacity	kW	1.20	2.61	3.20	1.20	2.61	3.20
		BTU/h	4100	8900	10900	4100	8900	10900
	Running Current	A	-	3.4	-	-	3.0	-
	Input Power	W	300	600	960	300	600	960
	COP	W/W	4.00	4.35	3.33	4.00	4.35	3.33
		Btu/hW	13.65	14.85	11.35	13.65	14.85	11.35
	Indoor Noise (H / L)	dB-A	35 / 28			35 / 28		
Power Level dB		51 / -			51 / -			
Indoor Fan	Type		Sirocco					
	Material		GFZ010A / GF20					
	Motor Type		Transistor (8-poles)					
	Input Power		W					
	Output Power		W					
	Speed	QLo	Cool	rpm		880		
			Heat	rpm		800		
		Lo	Cool	rpm		940		
			Heat	rpm		880		
		Me	Cool	rpm		1080		
			Heat	rpm		1040		
		Hi	Cool	rpm		1200		
			Heat	rpm		1200		
	SHi	Cool	rpm		1320			
Heat		rpm		1320				
Moisture Removal		L/h (Pt/h)		0.4 (0.8)				
Indoor Airflow	QLo	Cool	m ³ /min (ft ³ /min)		9.30 (328)			
		Heat	m ³ /min (ft ³ /min)		8.50 (300)			
	Lo	Cool	m ³ /min (ft ³ /min)		9.90 (350)			
		Heat	m ³ /min (ft ³ /min)		9.30 (328)			
	Me	Cool	m ³ /min (ft ³ /min)		11.20 (395)			
		Heat	m ³ /min (ft ³ /min)		10.90 (385)			
	Hi	Cool	m ³ /min (ft ³ /min)		12.90 (455)			
		Heat	m ³ /min (ft ³ /min)		12.90 (455)			
	SHi	Cool	m ³ /min (ft ³ /min)		13.70 (484)			
		Heat	m ³ /min (ft ³ /min)		13.70 (484)			

Model		Indoor	CS-ME5SD3UA	
		Outdoor	CU-2E18SBU	
Dimension	Height (I/D)	mm (inch)	200 (7-7/8)	
	Width (I/D)	mm (inch)	750 (29-17/32)	
	Depth (I/D)	mm (inch)	640 (25-7/32)	
Weight	Net (I/D)	kg (lb)	19 (42)	
Piping	Pipe Diameter (Liquid / Gas)	mm (inch)	6.35 (1/4) / 9.52 (3/8)	
Drain Hose	Inner Diameter	mm (inch)	16 (0.63)	
	Length	mm (inch)	117 (4.63)	
Indoor Heat Exchanger	Fin Material		Aluminium (Pre Coat)	
	Fin Type		Slit Fin	
	Row x Stage x FPI		3 x 12 x 18	
	Size (W x H x L)	mm (inch)	590 x 282 x 38.1	
Power Supply			Outdoor	
Power Supply Cord		A	-	
			DRY BULB	WET BULB
Indoor Operation Range (Cooling)	Maximum °F (°C)		89.6 (32)	73.4 (23)
	Maximum °F (°C)		60.8 (16)	51.8 (11)
Outdoor Operation Range (Cooling)	Maximum °F (°C)		114.8 (46)	78.8 (26)
	Maximum °F (°C)		14.0 (-10)	-
Indoor Operation Range (Heating)	Maximum °F (°C)		86.0 (30)	-
	Maximum °F (°C)		60.8 (16)	-
Outdoor Operation Range (Heating)	Maximum °F (°C)		75.2 (24)	64.4 (18)
	Maximum °F (°C)		-4 (-20)	-5.8 (-21)

1. Cooling capacities are based on indoor temperature of 27°C Dry Bulb (80.6°F Dry Bulb), 19.0°C Wet Bulb (66.2°F Wet Bulb) and outdoor air temperature of 35°C Dry Bulb (95°F Dry Bulb), 24°C Wet Bulb (75.2°F Wet Bulb).
2. Heating capacities are based on indoor temperature of 20°C Dry Bulb (68°F Dry Bulb) and outdoor air temperature of 7°C Dry Bulb (44.6°F Dry Bulb), 6°C Wet Bulb (42.8°F Wet Bulb).
3. Specifications are subjected to change without notice for further improvement.

Model		Indoor		CS-ME7SD3UA					
		Outdoor		CU-2E18SBU					
Performance Test Condition				AHRI					
Power Supply		Phase, Hz		Single, 60					
		V		208		230			
		Min.	Mid.	Max.	Min.	Mid.	Max.		
Cooling	Capacity		kW	1.80	2.01	2.90	1.80	2.01	2.90
			BTU/h	6100	6900	9900	6100	6900	9900
	Running Current		A	-	2.8	-	-	2.5	-
	Input Power		W	340	500	810	340	500	810
	EER		W/W	5.29	4.02	3.58	5.29	4.02	3.58
			Btu/hW	17.95	13.80	12.20	17.95	13.80	12.20
Indoor Noise (H / L)		dB-A	36 / 29			36 / 29			
		Power Level dB	52 / -			52 / -			
Heating	Capacity		kW	1.20	3.21	4.10	1.20	3.21	4.10
			BTU/h	4100	10900	14000	4100	10900	14000
	Running Current		A	-	4.1	-	-	3.7	-
	Input Power		W	300	740	1.23k	300	740	1.23k
	COP		W/W	4.00	4.34	3.33	4.00	4.34	3.33
			Btu/hW	13.65	14.75	11.40	13.65	14.75	11.40
Indoor Noise (H / L)		dB-A	36 / 29			36 / 29			
		Power Level dB	52 / -			52 / -			
Indoor Fan	Type		Sirocco						
	Material		GFZ010A / GF20						
	Motor Type		Transistor (8-poles)						
	Input Power		W	-					
	Output Power		W	51					
	Speed	QLo	Cool	rpm	880				
			Heat	rpm	800				
		Lo	Cool	rpm	940				
			Heat	rpm	880				
		Me	Cool	rpm	1090				
			Heat	rpm	1060				
		Hi	Cool	rpm	1230				
			Heat	rpm	1230				
	SHi	Cool	rpm	1350					
Heat		rpm	1350						
Moisture Removal			L/h (Pt/h)	0.5 (1.1)					
Indoor Airflow	QLo	Cool	m ³ /min (ft ³ /min)	9.30 (328)					
		Heat	m ³ /min (ft ³ /min)	8.50 (300)					
	Lo	Cool	m ³ /min (ft ³ /min)	9.90 (350)					
		Heat	m ³ /min (ft ³ /min)	9.30 (328)					
	Me	Cool	m ³ /min (ft ³ /min)	11.35 (401)					
		Heat	m ³ /min (ft ³ /min)	11.05 (390)					
	Hi	Cool	m ³ /min (ft ³ /min)	13.20 (465)					
		Heat	m ³ /min (ft ³ /min)	13.20 (465)					
SHi	Cool	m ³ /min (ft ³ /min)	14.00 (494)						
	Heat	m ³ /min (ft ³ /min)	14.00 (494)						

Model		Indoor	CS-ME7SD3UA	
		Outdoor	CU-2E18SBU	
Dimension	Height (I/D)	mm (inch)	200 (7-7/8)	
	Width (I/D)	mm (inch)	750 (29-17/32)	
	Depth (I/D)	mm (inch)	640 (25-7/32)	
Weight	Net (I/D)	kg (lb)	19 (42)	
Piping	Pipe Diameter (Liquid / Gas)	mm (inch)	6.35 (1/4) / 9.52 (3/8)	
Drain Hose	Inner Diameter	mm (inch)	16 (0.63)	
	Length	mm (inch)	117 (4.63)	
Indoor Heat Exchanger	Fin Material		Aluminium (Pre Coat)	
	Fin Type		Slit Fin	
	Row x Stage x FPI		3 x 12 x 18	
	Size (W x H x L)	mm (inch)	590 x 282 x 38.1	
Power Supply			Outdoor	
Power Supply Cord		A	-	
			DRY BULB	WET BULB
Indoor Operation Range (Cooling)	Maximum °F (°C)		89.6 (32)	73.4 (23)
	Maximum °F (°C)		60.8 (16)	51.8 (11)
Outdoor Operation Range (Cooling)	Maximum °F (°C)		114.8 (46)	78.8 (26)
	Maximum °F (°C)		14.0 (-10)	-
Indoor Operation Range (Heating)	Maximum °F (°C)		86.0 (30)	-
	Maximum °F (°C)		60.8 (16)	-
Outdoor Operation Range (Heating)	Maximum °F (°C)		75.2 (24)	64.4 (18)
	Maximum °F (°C)		-4 (-20)	-5.8 (-21)

- Cooling capacities are based on indoor temperature of 27°C Dry Bulb (80.6°F Dry Bulb), 19.0°C Wet Bulb (66.2°F Wet Bulb) and outdoor air temperature of 35°C Dry Bulb (95°F Dry Bulb), 24°C Wet Bulb (75.2°F Wet Bulb).
- Heating capacities are based on indoor temperature of 20°C Dry Bulb (68°F Dry Bulb) and outdoor air temperature of 7°C Dry Bulb (44.6°F Dry Bulb), 6°C Wet Bulb (42.8°F Wet Bulb).
- Specifications are subjected to change without notice for further improvement.

3. Features

- **Inverter Technology**
 - Wider output power range
 - Energy saving
 - Quick Cooling
 - Quick Heating
 - More precise temperature control
- **Environment Protection**
 - Non-ozone depletion substances refrigerant (R410A)
- **Long Installation Piping**
 - Long piping up to 25 meter (82 ft)
- **Easy to use remote control**
- **Quality Improvement**
 - Random auto restart after power failure for safety restart operation
 - Gas leakage protection
 - Prevent compressor reverse cycle
 - Inner protector to protect compressor
 - Noise prevention during soft dry operation
- **Operation Improvement**
 - Quiet mode to reduce the indoor unit operating sound
 - Powerful mode to reach the desired room temperature quickly
 - 24-hour timer setting
- **Serviceability Improvement**
 - Breakdown Self Diagnosis function

4. Location of Controls and Components

4.1 Indoor Unit

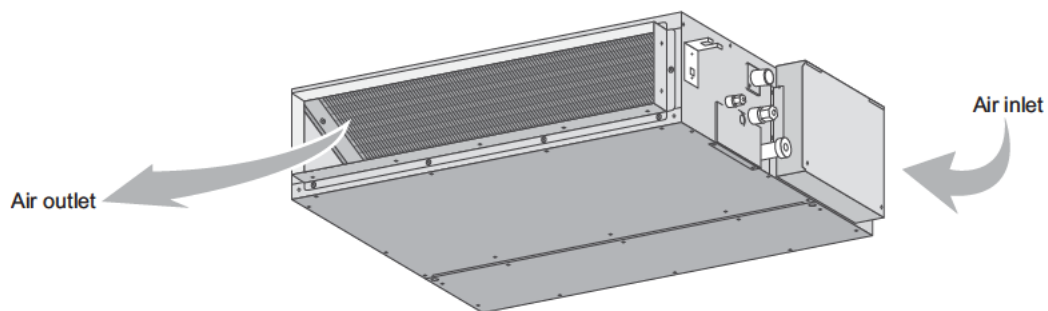

4.2 Remote Control

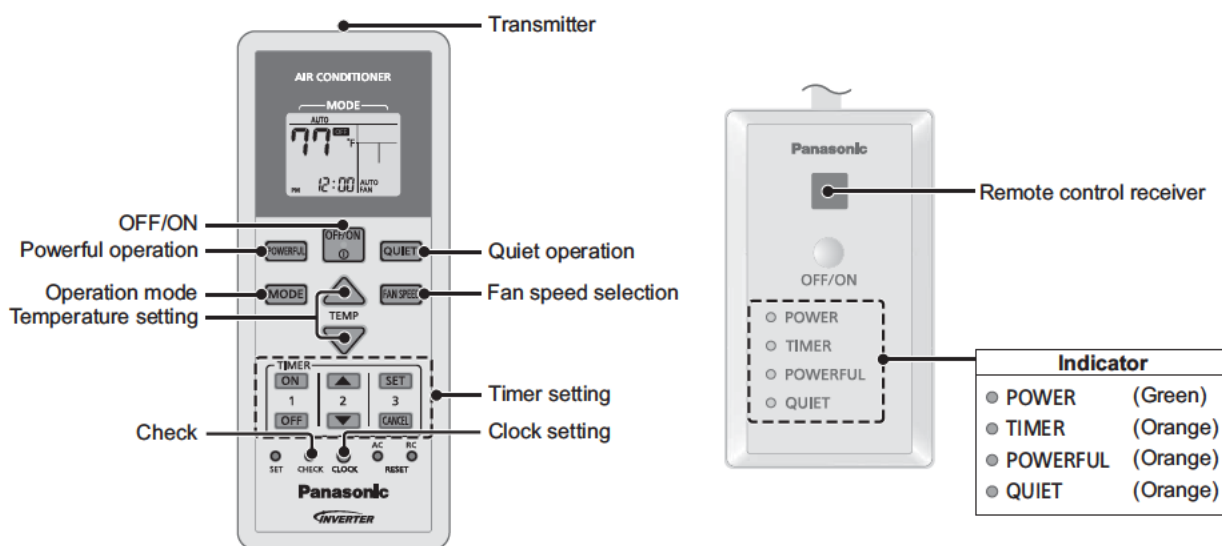

5. Dimensions

5.1 Indoor Unit

<Front View>

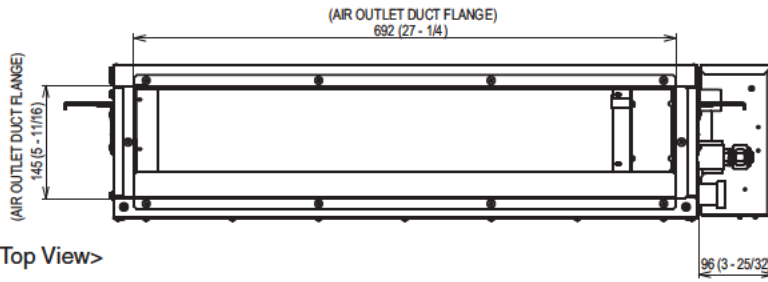

<Top View>

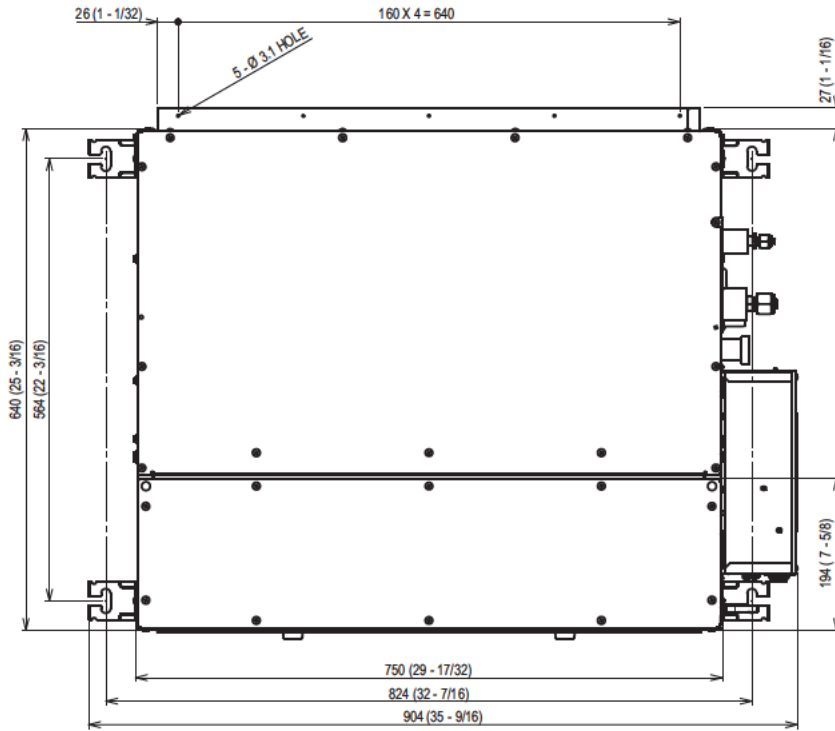

<Side View>

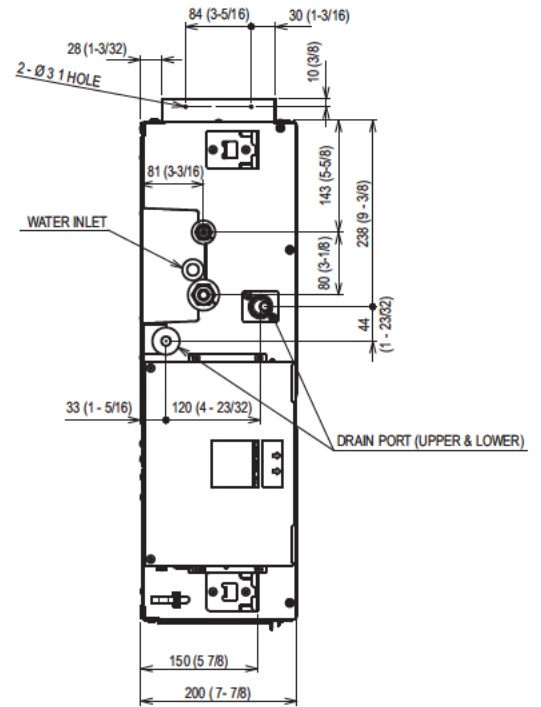

<Back View>

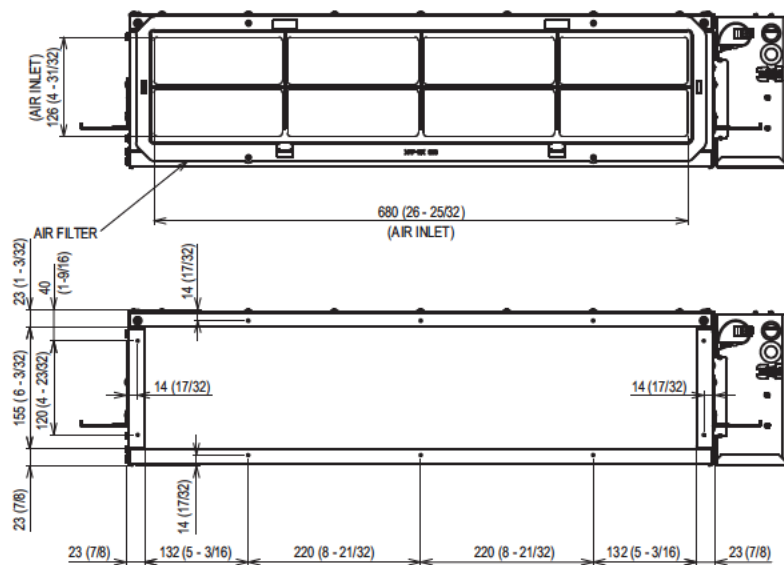

<Remote Control>

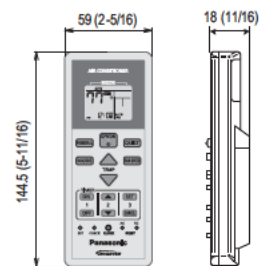

<Remote Control Holder>

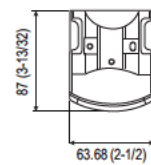

Unit : mm/inch

6. Refrigeration Cycle Diagram

6.1 Indoor Unit

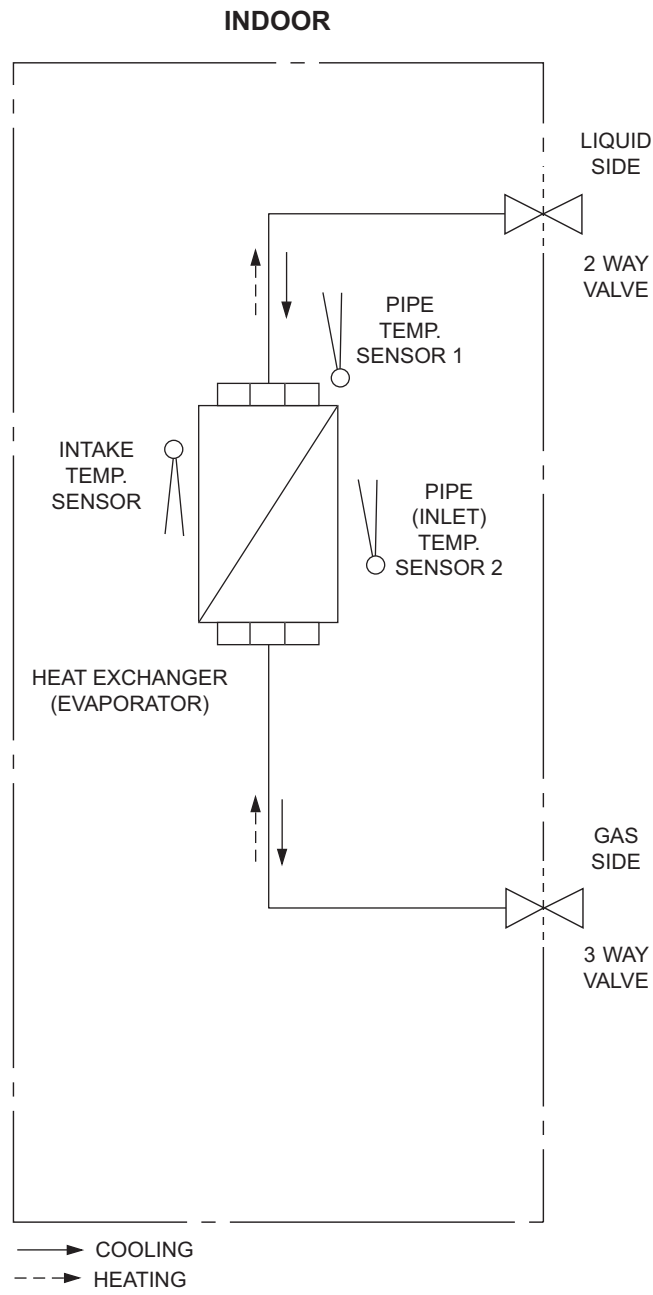

7. Block Diagram

7.1 Indoor Unit

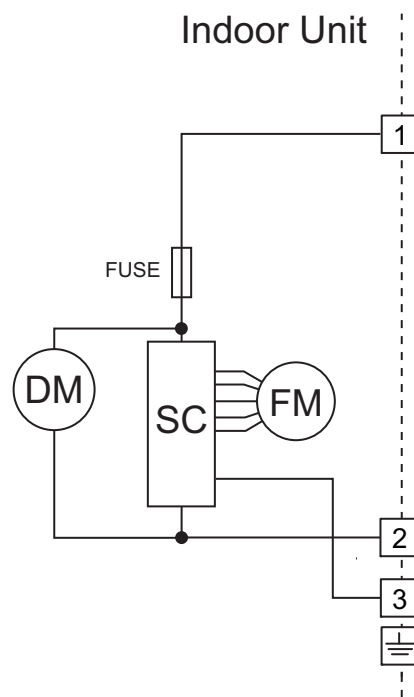

8. Wiring Connection Diagram

8.1 Indoor Unit

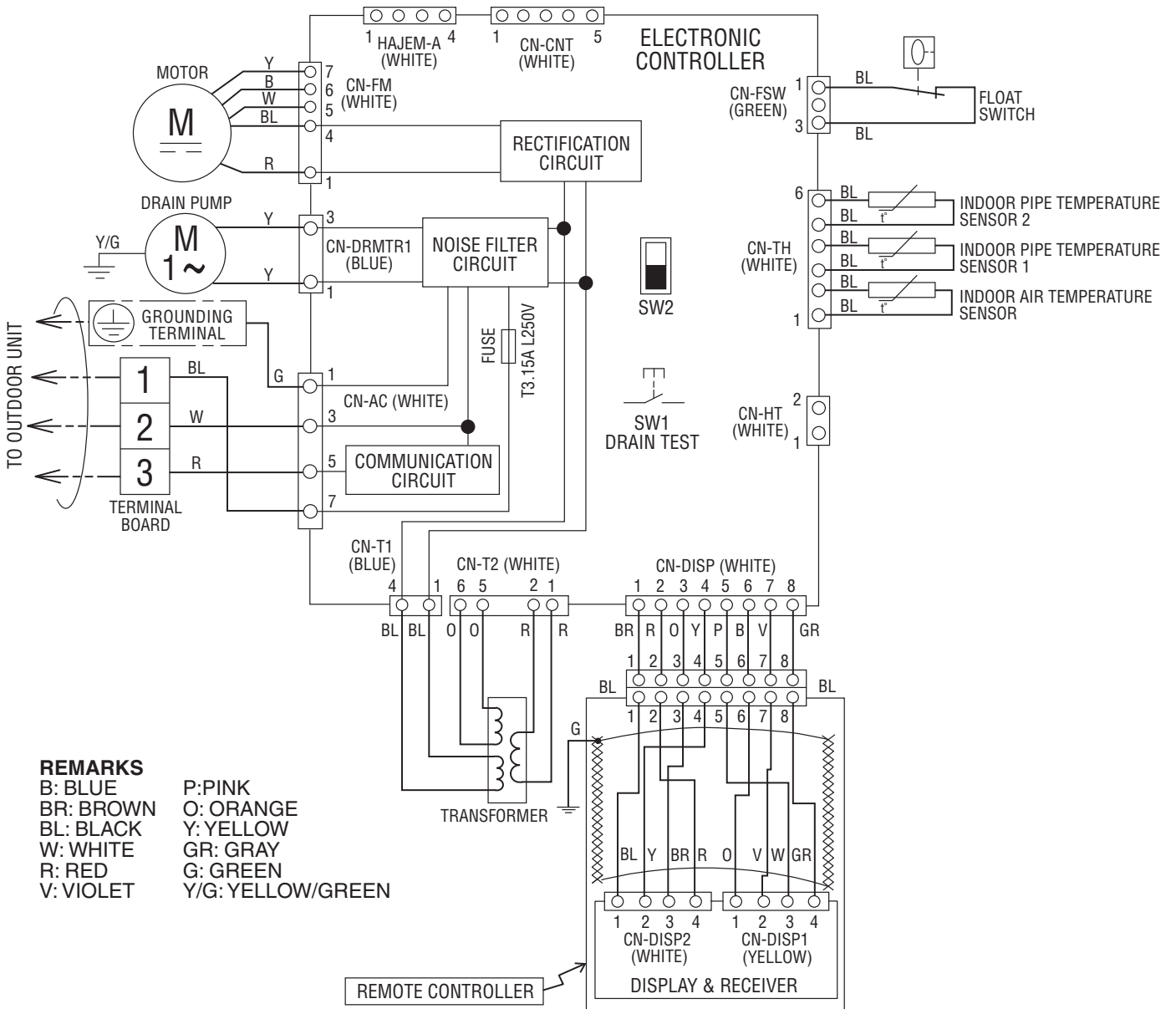

9. Electronic Circuit Diagram

9.1 Indoor Unit

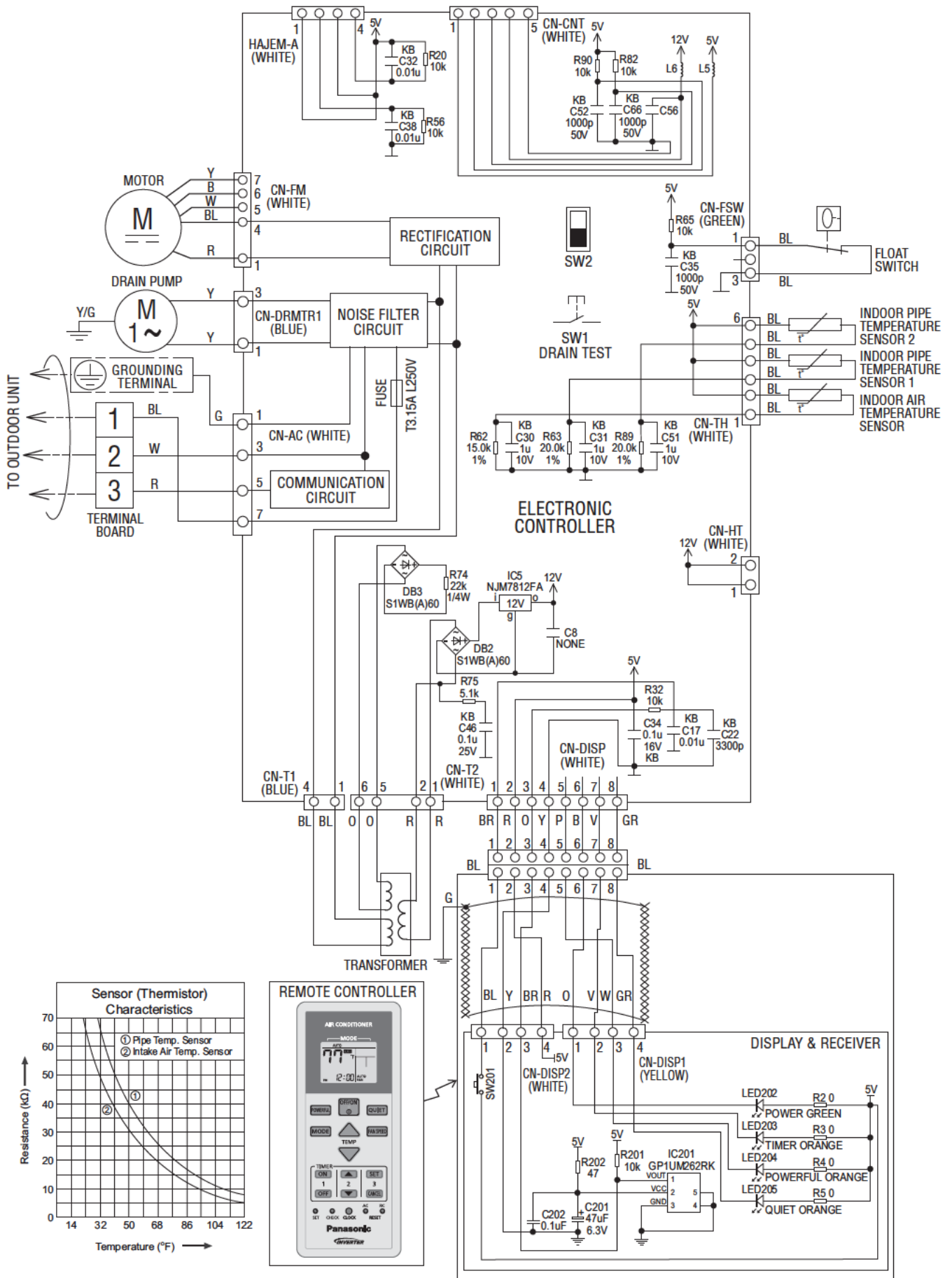

10. Printed Circuit Board



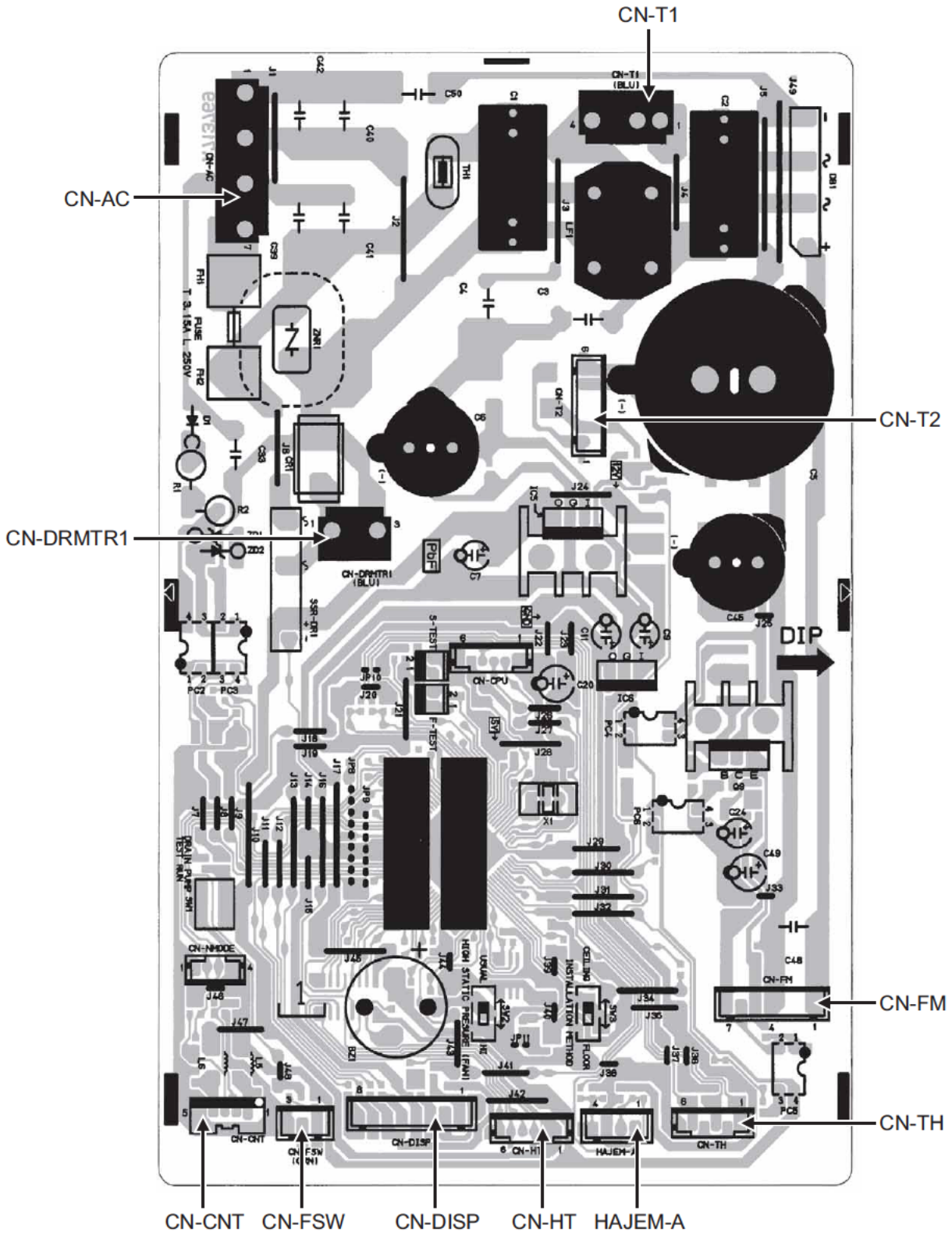

10.1 Indoor Unit





10.1.1 Main Printed Circuit Board







11. Installation Instruction

Attached Accessories

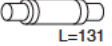
No.	Accessory part	Qty.
1	Remote control 	1
2	Battery 	2
3	Remote control holder 	1
4	Remote control holder fixing screw 	2
5	Remote control receiver 	1

No.	Accessory part	Qty.
6	Receiver fixing screw (M4 x 39/64" (15.5 mm)) 	2
7	Clamper (band) (for receiver cable fixing) 	1
8	Receiver cable (6.56 ft (2 m)) 	1
9	Washer (for suspension fitting) 	8
10	Flare insulator (for gas pipe / liquid pipe connection) 	2

No.	Accessory part	Qty.
11	Clamper (band) (for flare & drain insulating connection) 	4
12	Drain hose (for unit & PVC pipe connection) L=131 	1
13	Hose band (for drain hose connection) 	1
14	Drain hose insulation (for drain pipe connection) 	2
15	Clamper (band) (for power supply cord)  * Be sure to fix the power supply cord with clamper (band).	1

Required Materials

- Read the catalog and other technical materials and prepare the required materials.
- Applicable piping kit

Applicable piping kit	Piping size	
	Gas	Liquid
CZ-3F5, 7BP	3/8" (9.52 mm)	1/4" (6.35 mm)
CZ-4F5, 7, 10BP	1/2" (12.7 mm)	1/4" (6.35 mm)
CZ-52F5, 7, 10BP	5/8" (15.88 mm)	1/4" (6.35 mm)

Other Items to be Prepared (Locally Purchased)

Product name	Remarks
Rigid PVC pipe	VP20 (outer diameter ϕ 1 1/32" (ϕ 26)); also sockets, elbows and other parts as necessary
Adhesive	PVC adhesive
Insulation	For refrigerant piping insulation: foamed polyethylene with a thickness of 5/16" (8 mm) or more. For drain piping insulation: foamed polyethylene with a thickness of 13/32" (10 mm) or more.
Indoor/outdoor connecting cable	UL listed or CSA approved 4 conductor wires minimum AWG16
Hanging bolt related parts	Hanging bolts (M10) (4) and nuts (12), (when hanging the indoor unit)

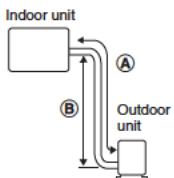
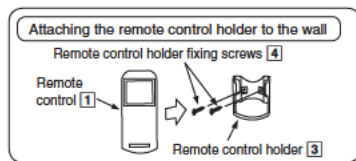
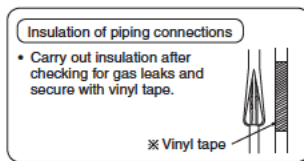

IMPORTANT
Begin the installation job from the "Indoor Unit" installation.

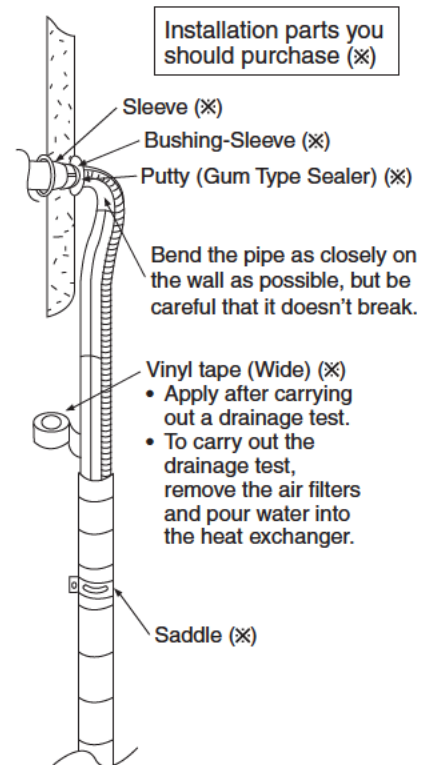

It is advisable to avoid more than 2 blockage directions. For better ventilation & multiple-outdoor installation, please consult authorized dealer/specialist.

- This illustration is for explanation purposes only. The indoor unit will actually face a different way.
- Respective outdoor unit installation procedure shall refer to instruction manual provided in the outdoor unit packaging.

11.1 Indoor Unit

11.1.1 Selecting the Installation Location

Take into consideration the following contents when creating the blueprint.

■ Indoor unit installation location

- Do not install the unit in excessive oil fume area such as kitchen, workshop and etc.
- The location should be strong enough to support the main unit without vibration.
- There should not be any heat or steam source nearby.
- Drainage should be easy. Avoid locating the drain port close to ditches (domestic wastewater).
- Avoid locations above entrances and exits.
- Do not block the air intake and discharge passages.
- Select the location that enables the cool and warm air to spread out to the entire room.
- Locate the indoor unit at least 3.28 ft (1 m) or more away from a TV, radio, wireless appliance, antenna cable and fluorescent light, and 6.56 ft (2 m) or more away from a telephone.
- Recommended installation height for indoor unit shall be at least 8.27 ft (2.5 m) from floor.

11.1.2 To Drill a Hole in the Wall and Install a Sleeve of Piping

- 1 Insert the piping sleeve to the hole.
- 2 Fix the bushing to the sleeve.
- 3 Cut the sleeve until it extrudes about 19/32" (15 mm) from the wall.

⚠ CAUTION

When the wall is hollow, be sure to use the sleeve for tube assembly to prevent pests from damaging the cables, e.g. mice biting the connection cable.

- 4 Finish by sealing the sleeve with putty or caulking compound at the final stage.

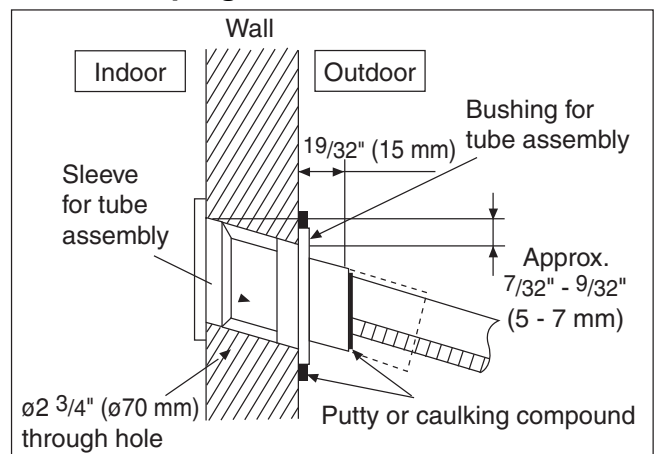

11.1.3 Installing the Indoor Unit (Installation Embedded in the Ceiling)

11.1.3.1 Preparation Before Installation

- Always provide sufficient entry and exit space to allow installation work, inspection and unit replacement.
- Waterproof the rear surface of the ceiling below the unit in consideration of water droplets forming and dropping.

⚠ CAUTION

When cooling operation is performed for an extended period under the following conditions, water droplets may form and drop. Attach locally purchased insulation (foamed polyethylene with a thickness of 7/32" (5 mm) or more) to the outside of the indoor unit before installing into the ceiling to improve heat insulation.

- Locations with a dew point inside the ceiling of 73.4°F (23°C) or more
 - Kitchens and other locations that produce large amounts of heat and steam
 - Locations where the inside of the ceiling serves as an outside air intake passage
- **When installing into a ceiling, select the unit position and airflow direction that enable the cool and warm air to spread out to the whole room.**
 - **Do not place objects that might obstruct the airflow within 3.28 ft (1 m) below the intake grill.**

Required Minimum Space for Installation and Service

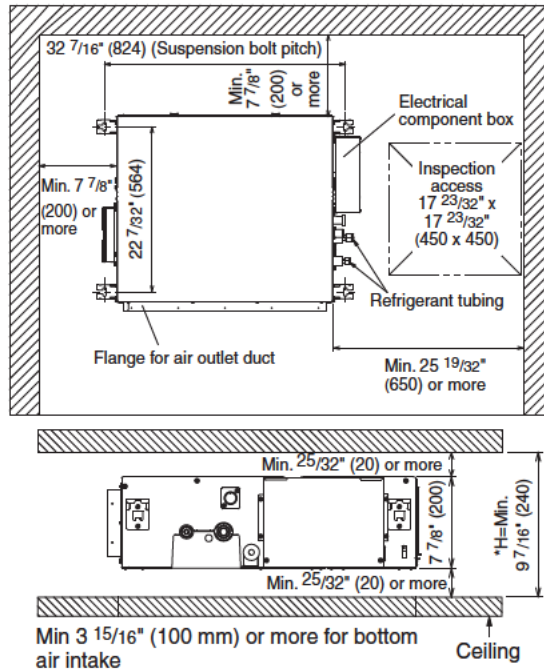

- H dimension means the minimum height of the unit installation space.
- Select H dimension such that a downward slope of at least 1/100 is ensured. Refer to 11.1.4 "Connecting the drain piping"

Dimension of the Indoor Unit

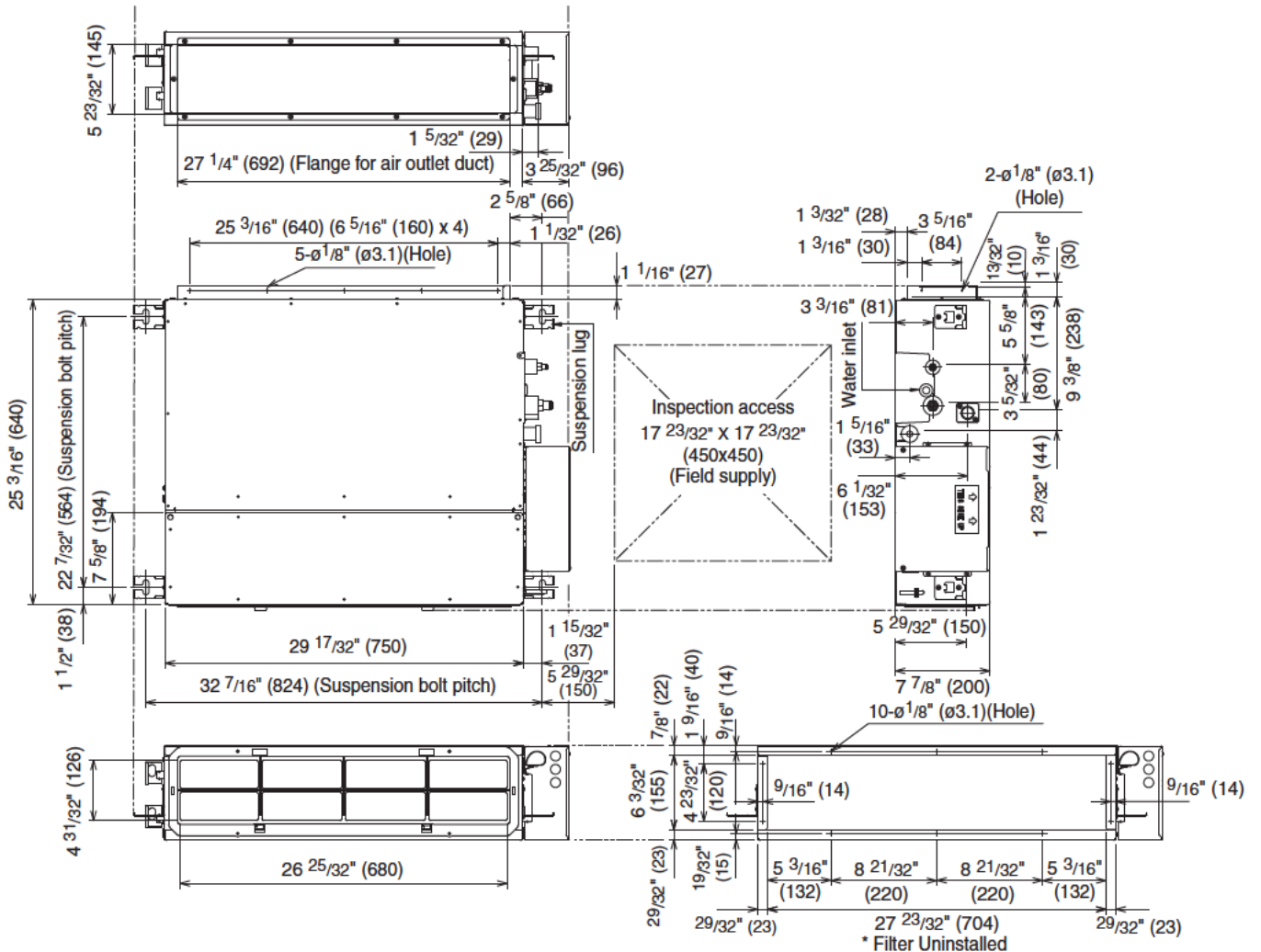

In Case of Bottom Intake

- 1 Remove the frame filter assy as shown in diagram ①
- 2 Remove cover plate as shown in diagram ①
- 3 Fix frame filter assy as shown in diagram ②
- 4 Fix cover plate as shown in diagram ② with the dummy hole downward.

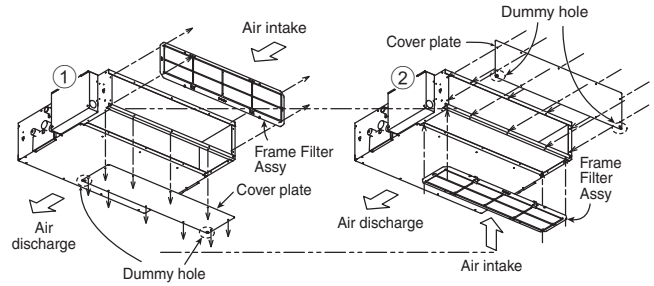

Fixing Frame Filter Assy

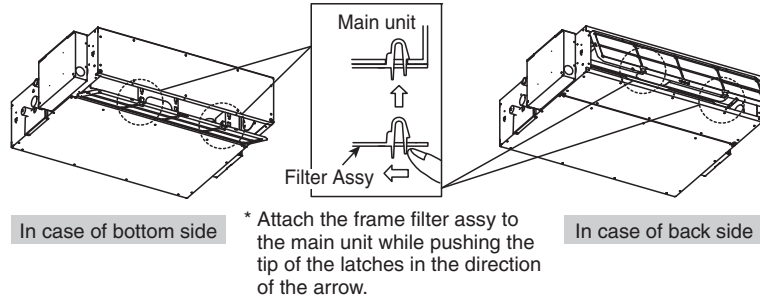

Ceiling Opening

- Install inspection opening 17 23/32" x 17 23/32" (450 mm x 450 mm) on the control box side where maintenance and inspection of the control box and drain pump are easy. Install another inspection opening 31 1/2" x 27 9/16" (800 mm x 700 mm) also at the lower part of the unit.

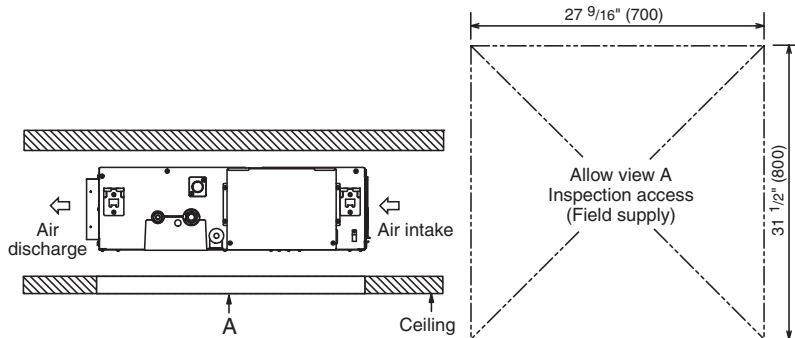

Securing the Hanging Bolts

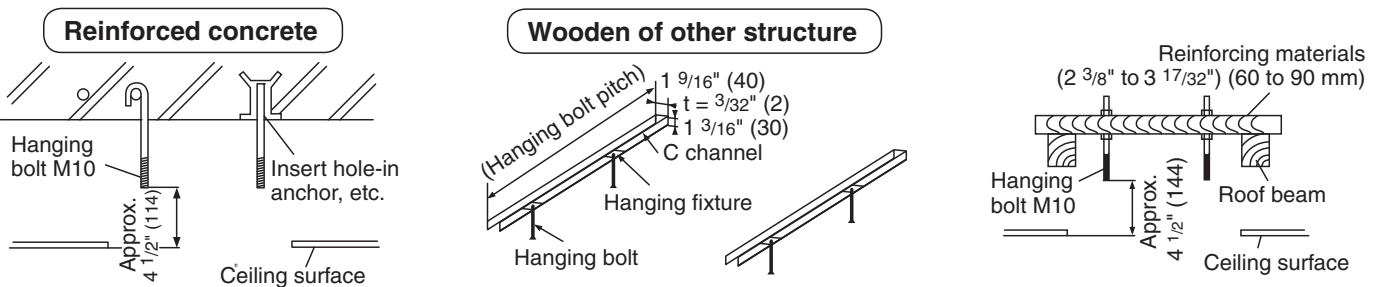

- Secure the hanging bolts (M10, locally purchased) firmly in a manner capable of supporting the unit weight.
- Consult your construction or interior contractor for details on finishing the ceiling opening.

Installing an Intake and Discharge Duct Type

- Ensure the range of unit external static pressure is not exceeded. Refer technical manual for the range of external static pressure setting.
- Connect the duct as shown.
- When attaching duct to the intake side, remove the product filter frame assy and replace with locally purchase intake-side flange by using flange by using 10 - $\text{Ø } 1/8''$ ($\text{Ø } 3.1$)(hole) screws.
- Wrap the flange and duct connection area with aluminium tape or similar to prevent air leak.

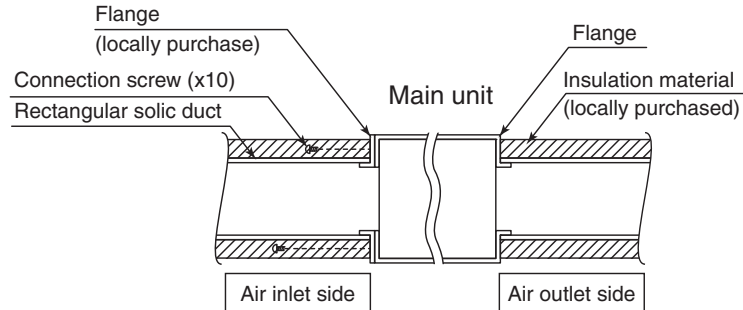

⚠ CAUTION

When attaching a duct to the intake-side, be sure to attach an air filter inside the air passage on the intake-side. (Use an air filter with dust collecting efficiency at least 50% in a gravimetric technique.)

Installation into the Ceiling

- Attach the nuts and washers to the hanging bolts, then lift up and hook the main unit onto the hanging fixtures.
- Check if the unit is leveled using a level or a vinyl hose filled partially with water.

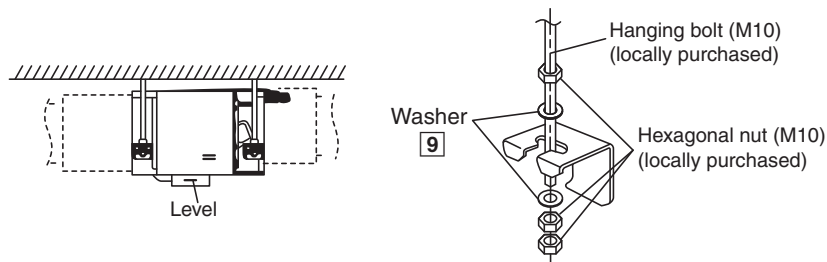

Mounting Remote Controller Receiver

⚠ CAUTION

Install the remote controller receiver cable at least 1 31/32" (50 mm) away from electric wires of other appliances to avoid miss-operation (electromagnetic noise).

1 Remove the bottom case.

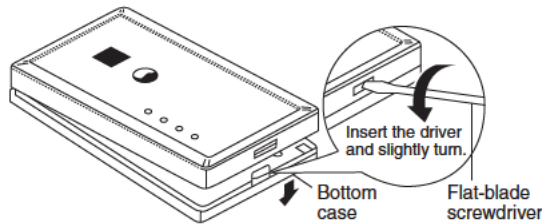

2 Mount to the wall.

Attention

Mounting the bottom case

- Tighten the screws securely until the screw heads touch the bottom case. (Otherwise, loose screw heads may hit the PCB and cause malfunction when mounting the top case.)
- Do not over-tighten the screws. (The bottom case may be deformed, resulting in fall of the unit.)

Connecting the remote control wiring

- Arrange the wires as shown in the illustration for ② as in diagram below, avoiding unnecessary wires being stored in the case. (Caught wires may destroy the PCB.)
- Avoid wires touching parts on the PCB. (Caught wires may destroy the PCB.)

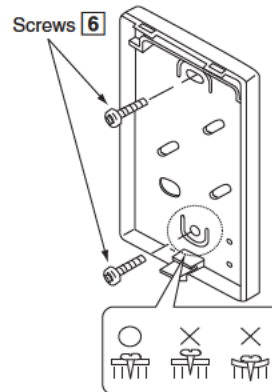

EXPOSED TYPE

Preparation: Make 2 holes for screws using a driver.

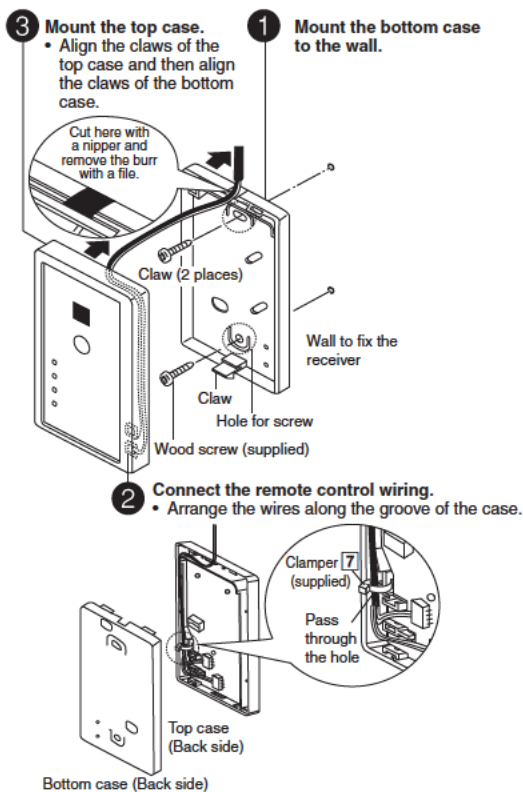

EMBEDDED TYPE

Preparation: Make 2 holes for screws using a driver.

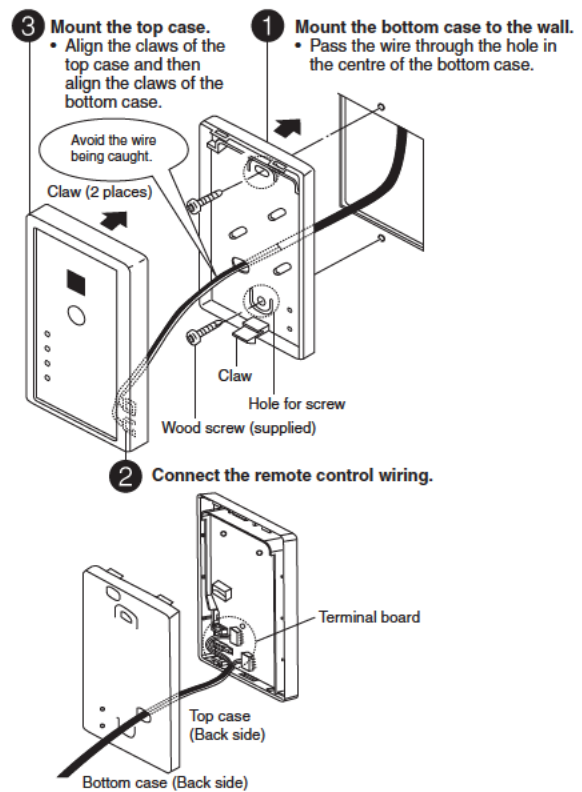

- Connect the indoor unit and the remote control receiver [5]. (Refer to the illustration.)
- Fix the green wire from receiver cable [8] to the grounding location provided inside control board.

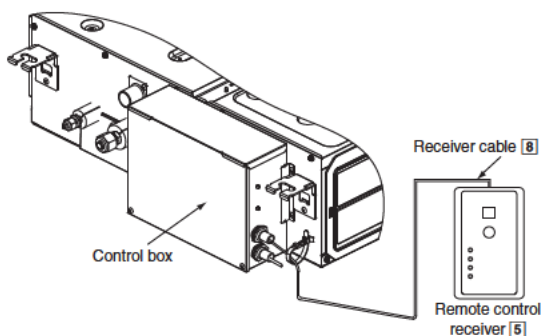

11.1.4 Connecting the Drain Piping

- Lay the drain piping so as to ensure drainage.
- Use a locally purchased VP20 general rigid PVC pipe (outer diameter $\phi 1\ 1/32''$ ($\phi 26$)) for the drain piping and firmly connect the indoor unit and the drain piping using supplied hose band to ensure that no leakage occurs.
- Drain piping located indoor should always be insulated by wrapping with locally purchased insulation (foamed polyethylene with a thickness of $13/32''$ (10 mm) or more).
- The drain piping should have a downward gradient (1/100 or more) and should be secured by using pipe hanging equipment to avoid creating hills or traps partway.
- Should there be any obstacle preventing the drain piping from being extended smoothly, the drain piping can be raised outside of the main unit as shown in the illustration below.

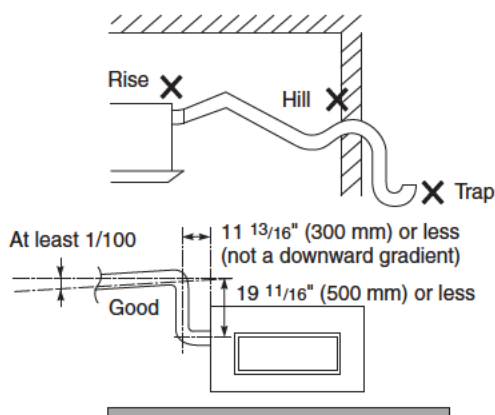
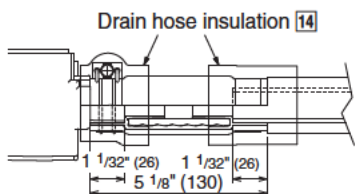
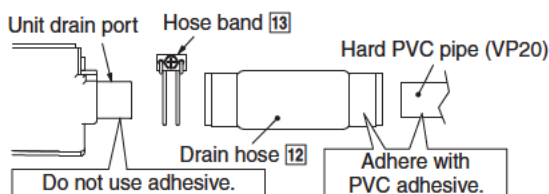

CAUTION

- Strictly do not install and extend the drain piping from the main unit drain water outlet horizontally or upward or raised it 19 11/16'' (500 mm) or more. Doing so may result in poor drainage or drain motor failure.
- Do not use drain hose bent at 90° angle. (The maximum permissible bend is 45°.)





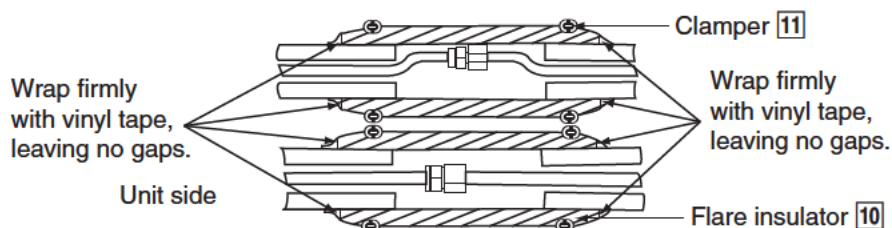

11.1.5 Insulating the Refrigerant Piping

- After the piping is connected, insulate. (Refer to the illustration)



11.1.6 Connect the Cable to the Indoor Unit

- Remove control box cover.
- Remove the plugs.
- Fix the conduit connections to the knockout holes together with lock nuts, then secure them against the control box side panel.
- Receiver cable wires **8** must pass through the upper conduit hole. Make sure the receiver cable is inserted from inside of the control box. Connect receiver cable connector to control box wire connector and fix it to the power supply cord holder as shown in the diagram. Insert firmly the connector of receiver cable **8** to connector at control box of indoor unit.
- Connection cable between indoor unit and outdoor unit should be UL listed or CSA approved 4 conductor wires minimum AWG16 in accordance with local electric codes.
 - Ensure that the terminal numbers on the indoor unit are connected to the same terminal numbers on the outdoor unit by the right coloured wires as shown in the diagram.
 - Earth lead wire should be longer than the other lead wires as shown in the diagram for electrical safety purpose in case the cord slips out from the anchorage.
 - Secure the cable onto the control board with the holder (clammer).

Terminals on the indoor unit	1	2	3	
Colour of wires				
Terminals on the outdoor unit	1	2	3	

CAUTION

When the wall is hollow, please be sure to use the sleeve for tube ass'y to prevent dangers caused by mice biting the connection cable.

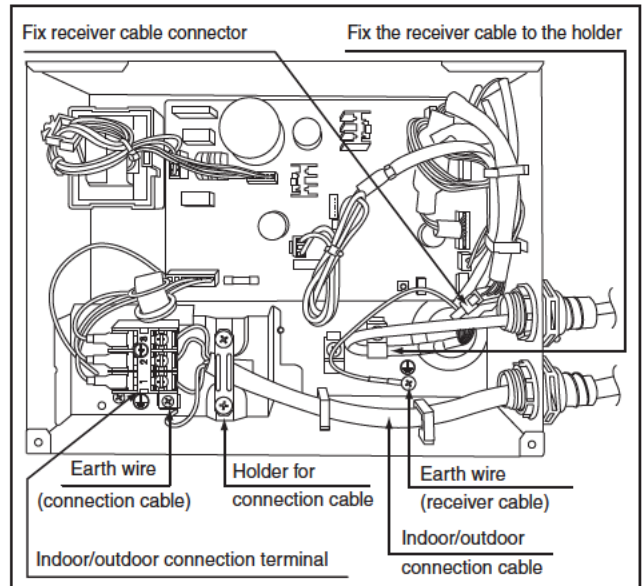
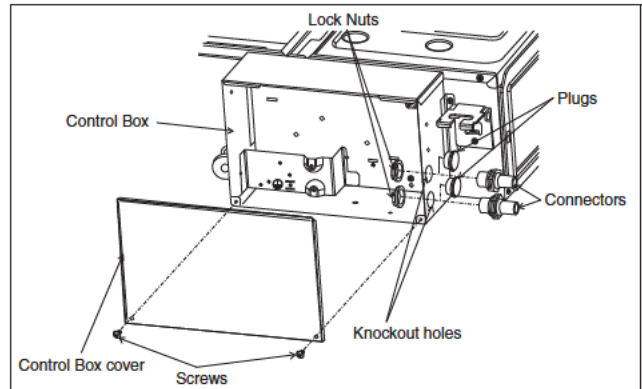

WARNING

 This equipment must be properly earthed.

- Ensure the colour of wires of outdoor unit and the terminal Nos. are the same to the indoor's respectively.
- Earth wire shall be Yellow/Green (Y/G) in colour and longer than other AC wires for safety reason.

11.1.6.1 Wire Stripping and Connecting Requirement

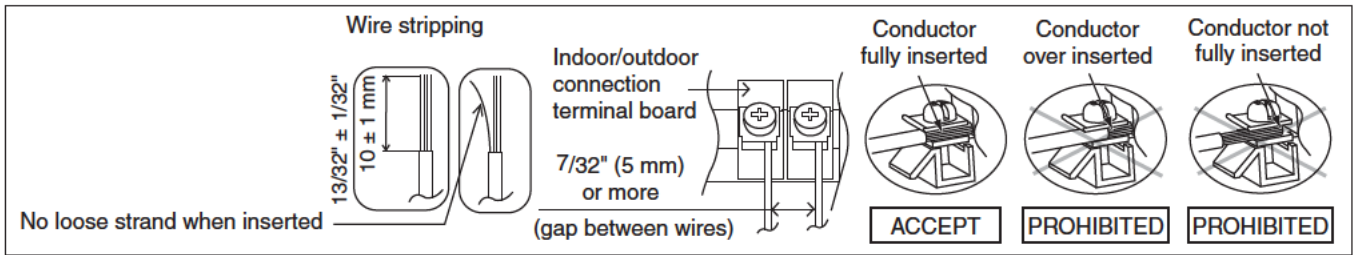

⊘ Do not joint wires

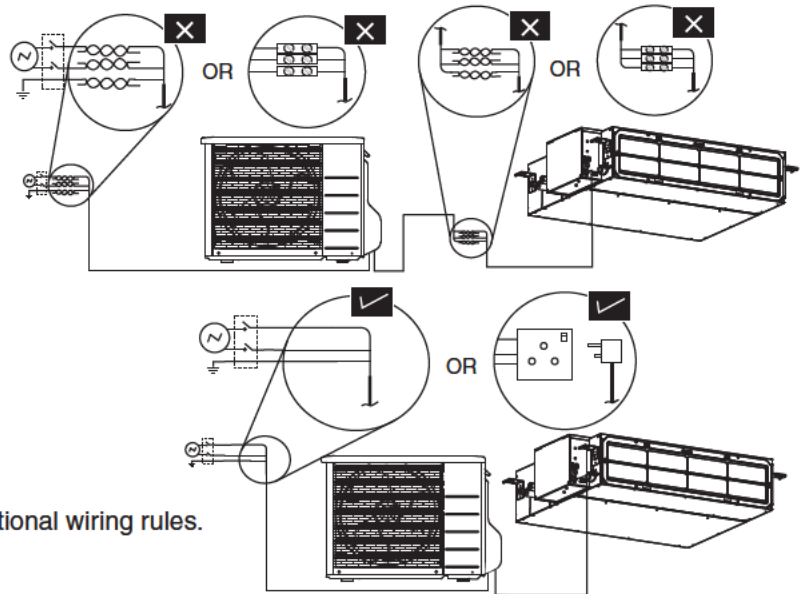
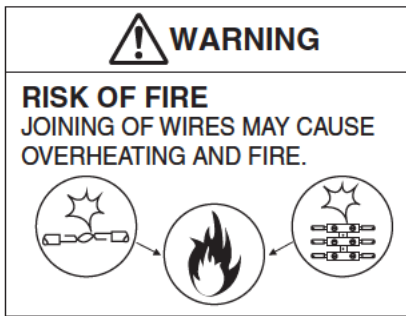

- ❗ Use complete wire without joining.
- ❗ Use approved socket and plug with earth pin.
- ❗ Wire connection in this area must follow to national wiring rules.

Switching the High State Switch (SW2)

- To increase the air volume, open the control box and on the control board, switch the FAN switch (SW2) to "HI".
- See the diagram for "Connecting the Indoor/Outdoor Connection Cable".

Note: Enabling Long-range Remote Control

- To maintain EMC emission limits, cabling interconnecting the HA terminal and subsequent opto-coupler, must be no more than 6.2 ft (1.9 m) length.
- Loop four turns of this cable through a suitable small EMC ferrite toroid, and protect with a short length of large diameter heat-shrink tube.
- There is no similar length limit for cable following on from the opto-coupler isolation.

CHECK THE DRAINAGE

Check after connecting the power supply.

- Pour approximately 600 cc of water into the drain pan of the main unit using a squeeze bottle, etc.
- Press the drain test run switch on the control board in the control box to start the drain motor and check whether the water drains normally. (The drain motor operates for approximately 5 minutes and then stops automatically.) (See the diagram for "Connecting the Indoor/Outdoor Connection Cable".)

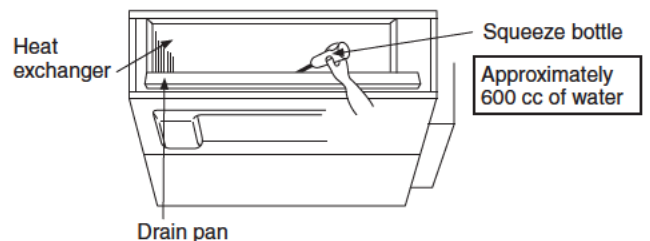

12. Operation and Control

12.1 Basic Function

Inverter control, which equipped with a microcomputer in determining the most suitable operating mode as time passes, automatically adjusts output power for maximum comfort always. In order to achieve the suitable operating mode, the microcomputer maintains the set temperature by measuring the temperature of the environment and performing temperature shifting. The compressor at outdoor unit is operating following the frequency instructed by the microcomputer at indoor unit that judging the condition according to internal setting temperature and intake air temperature.

12.1.1 Internal Setting Temperature

Once the operation starts, remote control setting temperature will be taken as base value for temperature shifting processes. These shifting processes are depending on the air conditioner settings and the operation environment. The final shifted value will be used as internal setting temperature and it is updated continuously whenever the electrical power is supplied to the unit.

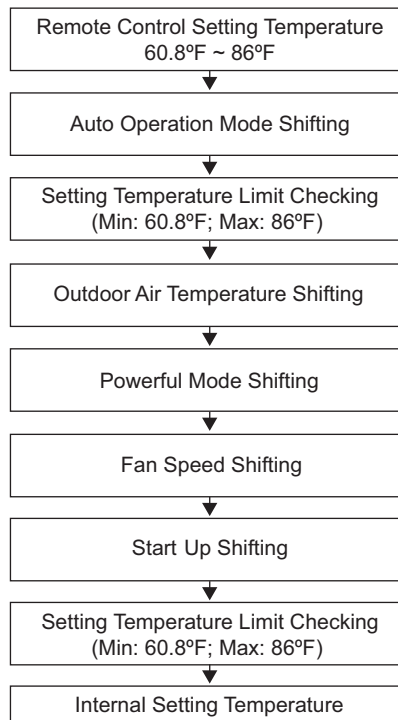

12.1.2 Cooling Operation

12.1.2.1 Thermostat control

- Compressor is OFF when Intake Air Temperature - Internal Setting Temperature < -3.6°F continue for 3 minutes.
- Compressor is ON after waiting for 3 minutes, if the Intake Air Temperature - Internal Setting Temperature > Compressor OFF point.

12.1.3 Soft Dry Operation

12.1.3.1 Thermostat control

- Compressor is OFF when Intake Air Temperature - Internal Setting Temperature < -3.6°F continue for 3 minutes.
- Compressor is ON after waiting for 3 minutes, if the Intake Air Temperature - Internal Setting Temperature > Compressor OFF point.

12.1.4 Heating Operation

12.1.4.1 Thermostat control

- Compressor is OFF when Intake Air Temperature - Internal Setting Temperature > +3.6°F.
- Compressor is ON after waiting for 3 minutes, if the Intake Air Temperature - Internal Setting Temperature < Compressor OFF point.

12.1.5 Automatic Operation

- This mode can be set using remote control and the operation is decided by remote control setting temperature, remote control operation mode and indoor intake air temperature.
- During operation mode judgment, indoor fan motor (with speed of Lo-) is running for 30 seconds to detect the indoor intake air temperature.
- Every 10 minutes, the indoor temperature is judged.
- For the 1st judgment
 - If indoor intake temperature - remote control setting temperature $\geq 3.6^\circ\text{F}$, COOL mode is decided.
 - If $-3.6^\circ\text{F} \leq$ indoor intake temperature - remote control setting temperature < 3.6°F, DRY mode is decided.
 - If indoor intake temperature - remote control setting temperature < -3.6°F, HEAT mode is decided.

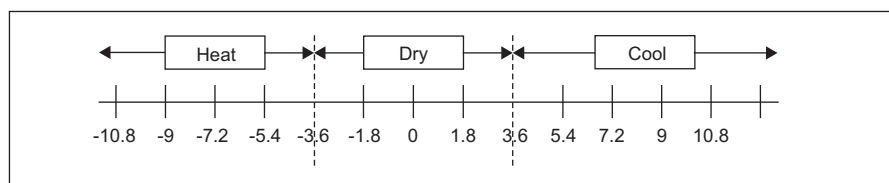

- For the 2nd judgment onwards
 - If indoor intake temperature - remote control setting temperature $\geq 5.4^\circ\text{F}$, if previous operate in DRY mode, then continue in DRY mode. Otherwise COOL mode is decided.
 - If $-3.6^\circ\text{F} \leq$ indoor intake temperature - remote control setting temperature < 5.4°F, maintain with previous mode.
 - If indoor intake temperature - remote control setting temperature < -3.6°F, HEAT mode is decided.

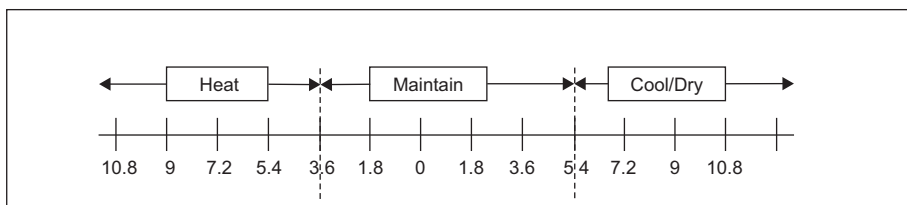

12.1.6 Indoor Fan Motor Operation

A. Basic Rotation Speed (rpm)

i. Manual Fan Speed

[Cooling, Dry]

- Fan motor's number of rotation is determined according to remote control setting.

Remote Control	O	O	O	O	O
Tab (rpm)	Hi	Me+	Me	Me-	Lo

[Heating]

- Fan motor's number of rotation is determined according to remote control setting.

Remote Control	O	O	O	O	O
Tab (rpm)	Shi	Me+	Me	Me-	Lo

ii. Auto Fan Speed

[Cooling, Dry]

- According to room temperature and setting temperature, indoor fan speed is determined automatically.

- The indoor fan will operate according to pattern below.

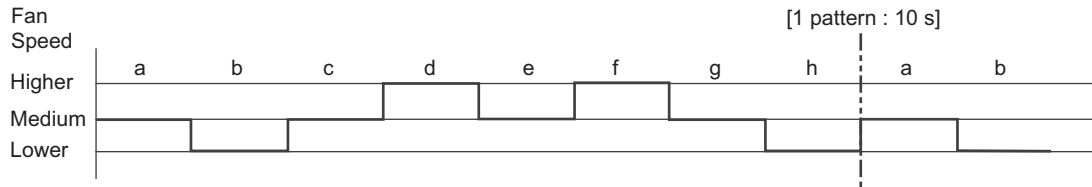

[Heating]

- According to indoor pipe temperature, automatic heating fan speed is determined as follows.

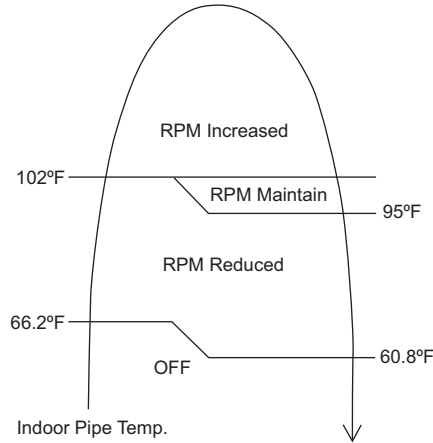

B. Feedback control

- Immediately after the fan motor started, feedback control is performed once every second.
- During fan motor on, if fan motor feedback ≥ 2550 rpm or < 50 rpm continue for 10 seconds, then fan motor error counter increase, fan motor is then stop and restart. If the fan motor counter becomes 7 times, then H19 - fan motor error is detected. Operation stops and cannot on back.

12.1.7 Outdoor Fan Motor Operation

Outdoor fan motor is operated with 15 fan speed. It starts when compressor starts operation and it stops 30 seconds after compressor stops operation.

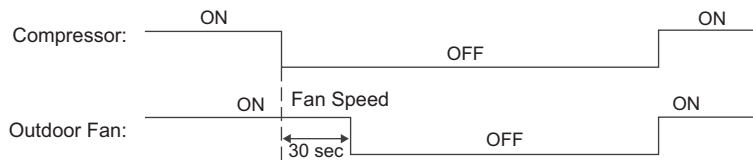

12.2 Quiet Operation (Cooling Mode/Cooling Area of Soft Dry Mode)

A. Purpose

To provide quiet cooling operation compare to normal operation.

B. Control condition

a. Quiet operation start condition

- When “quiet” button at remote control is pressed.
Quiet LED illuminates.

b. Quiet operation stop condition

- 1 When one of the following conditions is satisfied, quiet operation stops:
 - a. Powerful button is pressed.
 - b. Stop by OFF/ON switch.
 - c. Timer “off” activates.
 - d. Quiet button is pressed again.
- 2 When quiet operation is stopped, operation is shifted to normal operation with previous setting.
- 3 When fan speed is changed, quiet operation is shifted to quiet operation of the new fan speed.
- 4 When operation mode is changed, quiet operation is shifted to quiet operation of the new mode.
- 5 During quiet operation, if timer “on” activates, quiet operation maintains.
- 6 After off, when on back, quiet operation is not memorised.

C. Control contents

- 1 Auto fan speed is changed from normal setting to quiet setting of respective fan speed.
This is to reduce sound of Hi, Me, Lo for 3dB.
- 2 Manual fan speed for quiet operation is 1 step from setting fan speed.
- 3 Compressor frequency reduced.

12.2.1 Quiet operation (Heating)

A. Purpose

To provide quiet heating operation compare to normal operation.

B. Control condition

a. Quiet operation start condition

- When “quiet” button at remote control is pressed.
Quiet LED illuminates.

b. Quiet operation stop condition

- 1 When one of the following conditions is satisfied, quiet operation stops:
 - a. Powerful button is pressed.
 - b. Stop by OFF/ON switch.
 - c. Timer “off” activates.
 - d. Quiet button is pressed again.
- 2 When quiet operation is stopped, operation is shifted to normal operation with previous setting.
- 3 When fan speed is changed, quiet operation is shifted to quiet operation of the new fan speed.
- 4 When operation mode is changed, quiet operation is shifted to quiet operation of the new mode, except fan only mode.
- 5 During quiet operation, if timer “on” activates, quiet operation maintains.
- 6 After off, when on back, quiet operation is not memorised.

C. Control contents

a. Fan Speed Auto

- Indoor FM RPM depends on pipe temperature sensor of indoor heat exchanger.
Auto fan speed is changed from normal setting to quiet setting of respective fan speed.
This is to reduce sound of Hi, Me, Lo for 3dB.

b. Fan Speed Manual

- Manual fan speed for quiet operation is - 1 step from setting fan speed.

c. Compressor frequency reduced.

12.3 Powerful Mode Operation

When the powerful mode is selected, the internal setting temperature will shift higher up to +10.8°F (for Heating) or lower up to 7.2°F (for Cooling/Soft Dry) than remote control setting temperature for 20 minutes to achieve the setting temperature quickly.

12.4 Timer Control

12.4.1 ON Timer Control

ON timer can be set using remote control, the unit with timer set will start operate earlier than the setting time. This is to provide a comfortable environment when reaching the set ON time.

60 minutes before the set time, indoor (at fan speed of Lo-) and outdoor fan motor start operate for 30 seconds to determine the indoor intake air temperature and outdoor air temperature in order to judge the operation starting time.

From the above judgment, the decided operation will start operate earlier than the set time as shown below.

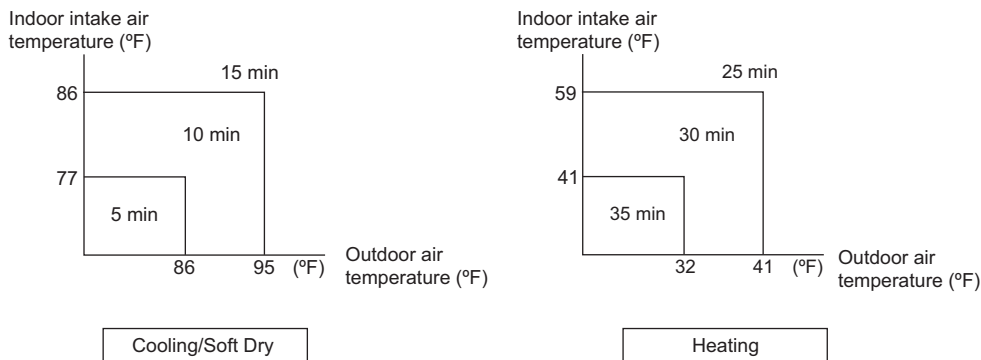

12.4.2 OFF Timer Control

OFF timer can be set using remote control, the unit with timer set will stop operate at set time.

12.5 Auto Restart Control

- 1 When the power supply is cut off during the operation of air conditioner, the compressor will re-operate within three to four minutes (there are 10 patterns between 2 minutes 58 seconds and 3 minutes 52 seconds to be selected randomly) after power supply resumes.
- 2 This type of control is not applicable during ON/OFF Timer setting.
- 3 This control can be omitted by open the circuit of JP10 at indoor unit printed board.

12.6 Indication Panel

LED	OFF/ON Operation
Color	Green
Light ON	Operation ON
Light OFF	Operation OFF

Note:

- If OFF/ON operation LED is OFF and OFF indicator does not shown on remote control display, there is an abnormality operation occurs.

12.7 Electric Heater Control 1

Starting condition

- A) When all condition (1+2+3+4+5+6+7) are fulfilled.
- 1 Operation ON
 - 2 Indoor Heating mode
 - 3 Thermostat ON
 - 4 Temperature different control

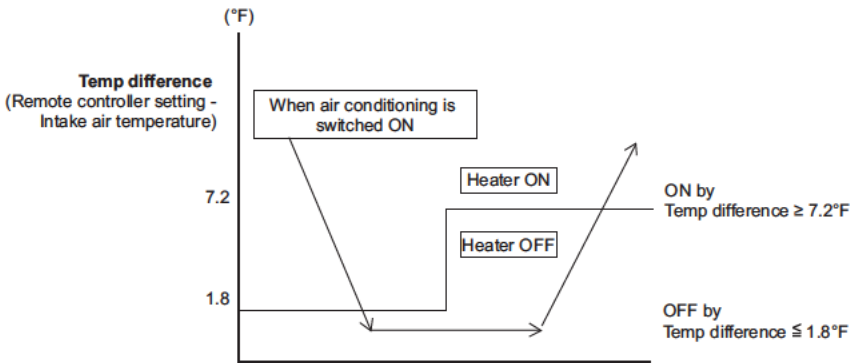

Example:

- 1 When air conditioning is switch ON,
Remote controller setting = 82.4°F
Intake air temperature = 78.8°F
Temp difference = 82.4-78.8 = 3.6°F
Heater ON
- 2 After a while when
Remote controller setting =82.4°F
Intake air temperature = 80.6°F
Temp difference = 82.4-80.6 =1.8°F
Heater OFF
- 3 After a while when
Temp difference ≥ 7.2°F
Heater ON

5 Intake air temperature control

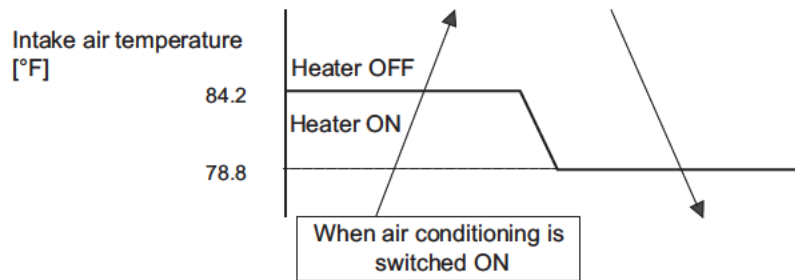

6 Evaporator pipe sensor control

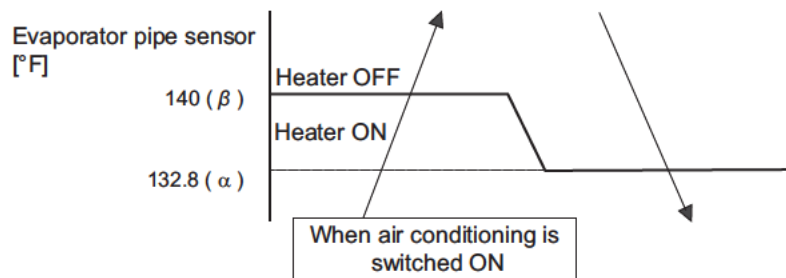

7 Indoor Fan speed ≥ Lo Fan

Control content

- 1 Electric heater will be switch ON when all condition for starting condition fulfilled.
- 2 Once Electric heater switched ON, It will operate at least 3 minutes.

12.8 Electric Heater Control 2

- During Error happened, air conditioning unit will stop operation, TIMER LED will blink and indoor vane closed.
- Electric heater can be switch ON when fulfill the starting condition as follow except 2 errors.
 - H14 (Indoor intake air temperature sensor abnormality)
 - H19 (Indoor fan motor mechanism lock)

Starting condition

When all condition (1+2+3+4) are fulfilled.

- 1 Operation ON
- 2 Indoor Heating mode
- 3 Error happened Except error H14 and H19
- 4 Temperature different control

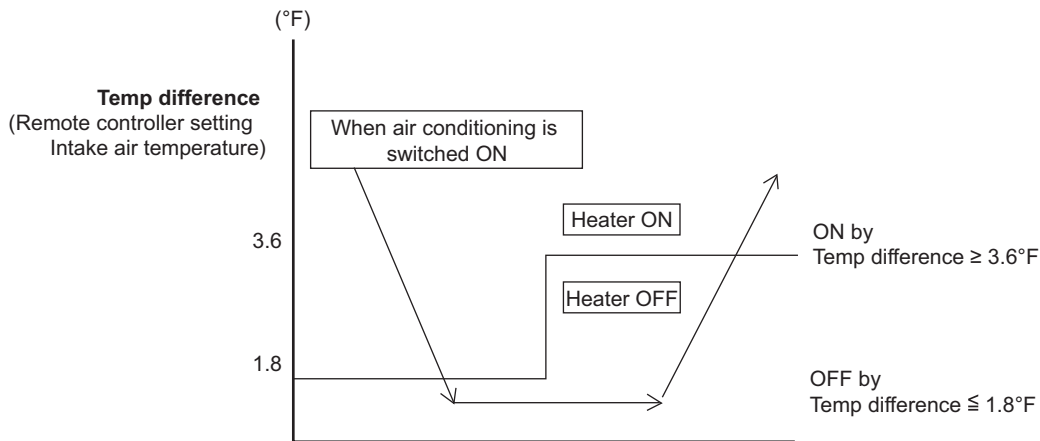

Control content

- 1 Indoor unit will start operate when receive operation ON signal from remote controller.
- 2 Indoor fan speed
 - i) For error
 - H23 - Indoor heat exchange sensor 1 abnormality
 - H24 - Indoor heat exchange sensor 2 abnormality
 - H27 - Outdoor air temperature sensor abnormality
 - H28 - Outdoor heat exchange sensor abnormality
 - ii) Other errors
 - minimum fan speed = Lo Fan
- 3 Once Electric heater switched ON, It will operate at least 3 minutes.

Me Fan
(Fan speed higher than other error because the outdoor unit compressor will still run at preset frequency about 27Hz (H23, H24) and 40Hz (H27, H28))

13. Servicing Mode

13.1 TEST RUN OPERATION (FOR PUMP DOWN/SERVICING PURPOSE)

- The Test Run operation will be activated by short-circuiting CN-S (Pin 1 & 2) at outdoor unit PCB after power supplied to outdoor unit terminal 1 and 2. The unit forced to run rated frequency cooling operation mode.

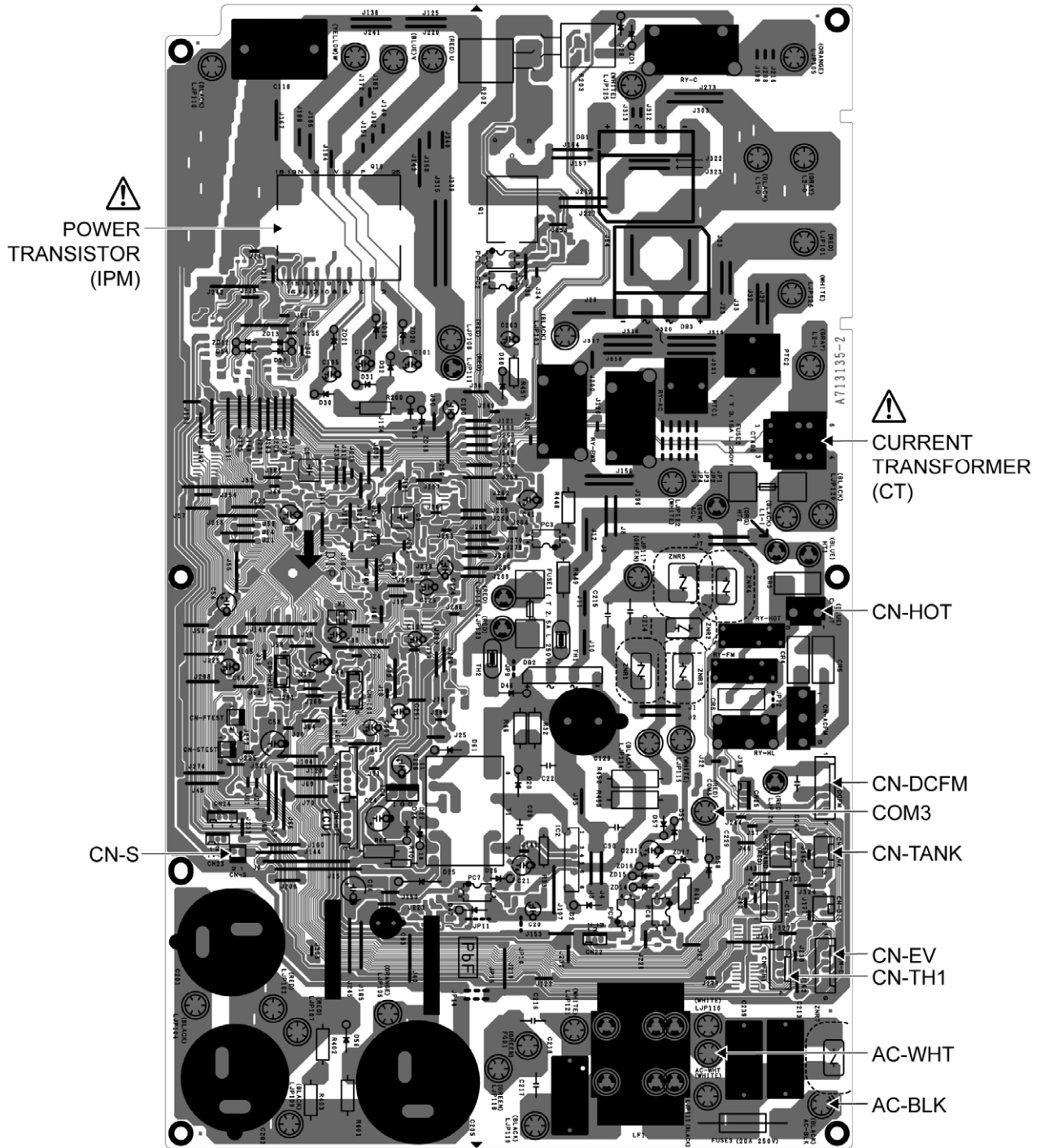

13.2 Auto OFF/ON Button

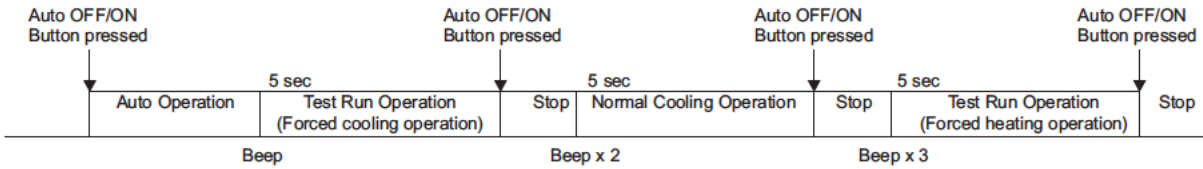

1 AUTO OPERATION MODE

The Auto operation will be activated immediately once the Auto OFF/ON button is pressed. This operation can be used to operate air conditioner with limited function if remote control is misplaced or malfunction.

2 TEST RUN OPERATION (FOR PUMP DOWN/SERVICING PURPOSE)

The Test Run operation will be activated if the Auto OFF/ON button is pressed continuously for more than 5 seconds. A “beep” sound will heard at the fifth seconds, in order to identify the starting of Test Run operation (Forced cooling operation). Within 5 minutes after Forced cooling operation start, the Auto OFF/ON button is pressed for more than 5 seconds. A 2 “beep” sounds will heard at the fifth seconds, in order to identify the starting of Normal cooling operation.

Within 5 minutes after Normal cooling operation start, the Auto OFF/ON button is pressed for more than 5 seconds. A 3 “beep” sounds will be heard at the fifth seconds, in order to identify the starting of Forced heating operation.

The Auto OFF/ON button may be used together with remote control to set / change the advance setting of air conditioner operation.

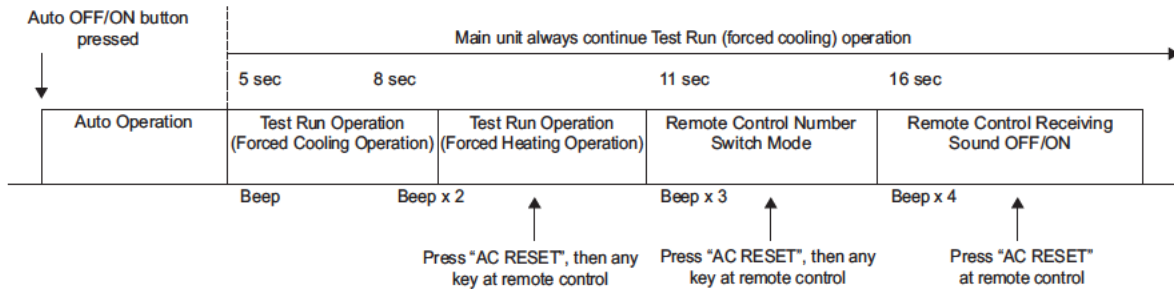

3 REMOTE CONTROL NUMBER SWITCH MODE

The Remote Control Number Switch Mode will be activated if the Auto OFF/ON button is pressed continuously for more than 11 seconds (3 “beep” sounds will occur at 11th seconds to identify the Remote Control Number Switch Mode is in standby condition) and press “AC RESET” button and then press any button at remote control to transmit and store the desired transmission code to the EEPROM.

There are 4 types of remote control transmission code could be selected and stored in EEPROM of indoor unit. The indoor unit will only operate when received signal with same transmission code from remote control. This could prevent signal interference when there are 2 or more indoor units installed nearby together. To change remote control transmission code, short or open jumpers at the remote control printed circuit board.

Remote Control Printed Circuit Board		
Jumper A (JA)	Jumper B (JB)	Remote Control No.
Short	Open	A (Default)
Open	Open	B
Short	Short	C
Open	Short	D

- During Remote Control Number Switch Mode, press any button at remote control to transmit and store the transmission code to the EEPROM.

13.3 Remote Controller Room Temperature Thermoshift Control

13.3.1 Purpose

To prevent not enough or over supply of cooling and heating capacity by adjusting the Room Temperature thermoshift by using remote controller.

Temperature can be adjusted are -3°C (-5.4°F), -2°C (-3.6°F), -1°C (-1.8°F), 0°C (0°F), 1°C (1.8°F), 2°C (3.6°F), 3°C (5.4°F)

Thermoshift adjusted by Remote controller will be stored into EEPROM and added into the final target setting temperature.

Function selection added to enable and disable this control.

13.3.2 Control method

Heating mode (using remocon function 58)

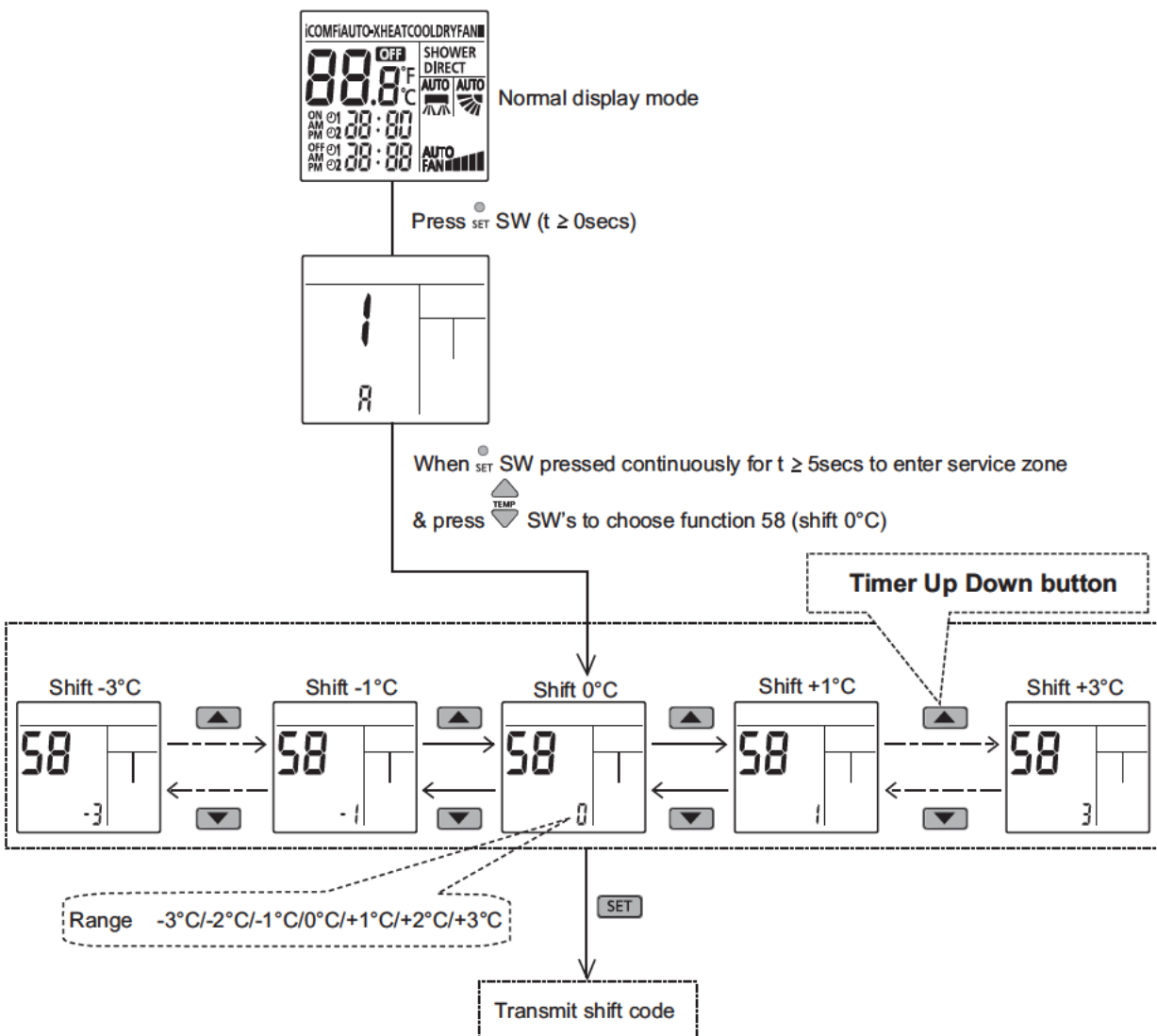

- ① Press **CANCEL** SW, special setting is immediately cancelled and normal mode starts.
- ② If no SW is pressed for 30secs, then special setting mode is cancelled and normal mode starts.
- ③ Under this function, only **TEMP**, **SET**, **CANCEL** & **RC RESET** SW's are effective.

Cooling or Dry mode (using remotecon function 59)

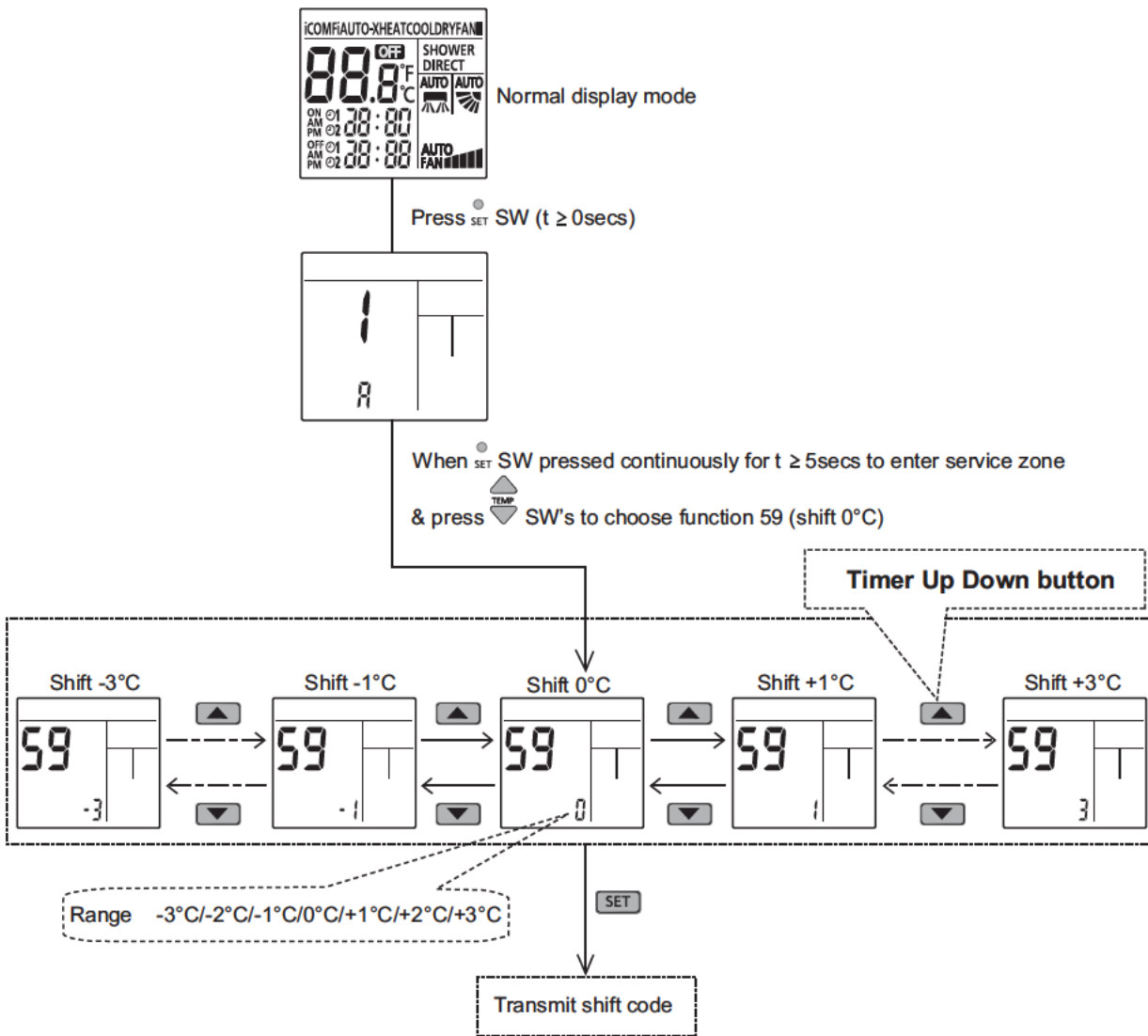

- ① Press CANCEL SW, special setting is immediately cancelled and normal mode starts.
- ② If no SW is pressed for 30secs, then special setting mode is cancelled and normal mode starts.
- ③ Under this function, only TEMP, SET, CANCEL & RC RESET SW's are effective.

Filter cleaning enable/disable selection

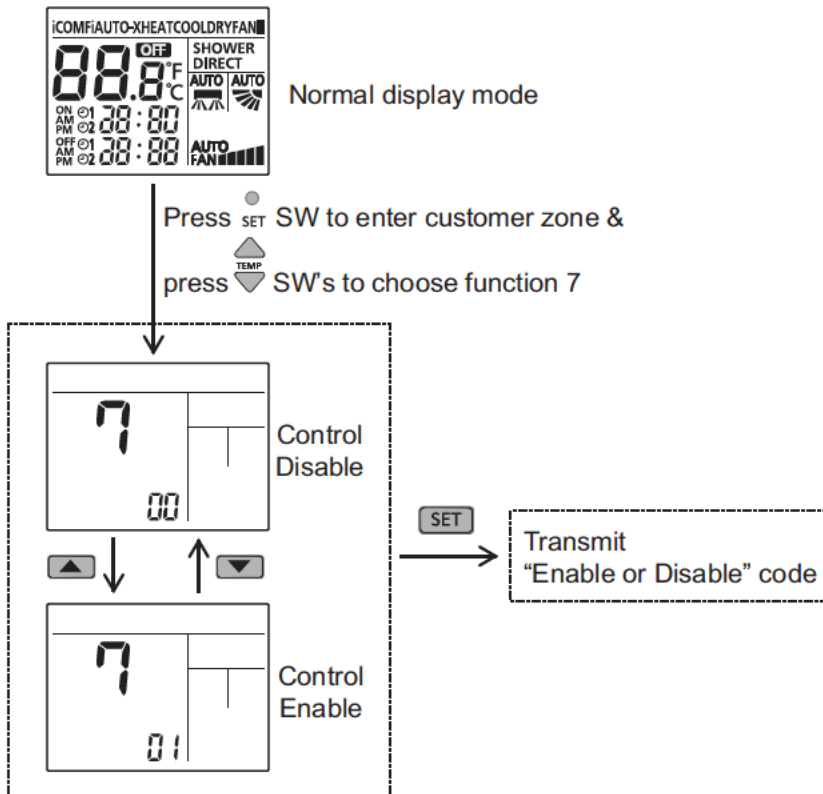

- ① Press **CANCEL** SW, special setting is immediately cancelled and normal mode starts.
- ② If no SW is pressed for 30secs, then special setting mode is cancelled and normal mode starts.
- ③ Under this function, only **SET**, **CANCEL** & **RESET** SW's are effective.

Note:

By default if enable.

Auto restart enable/disable selection

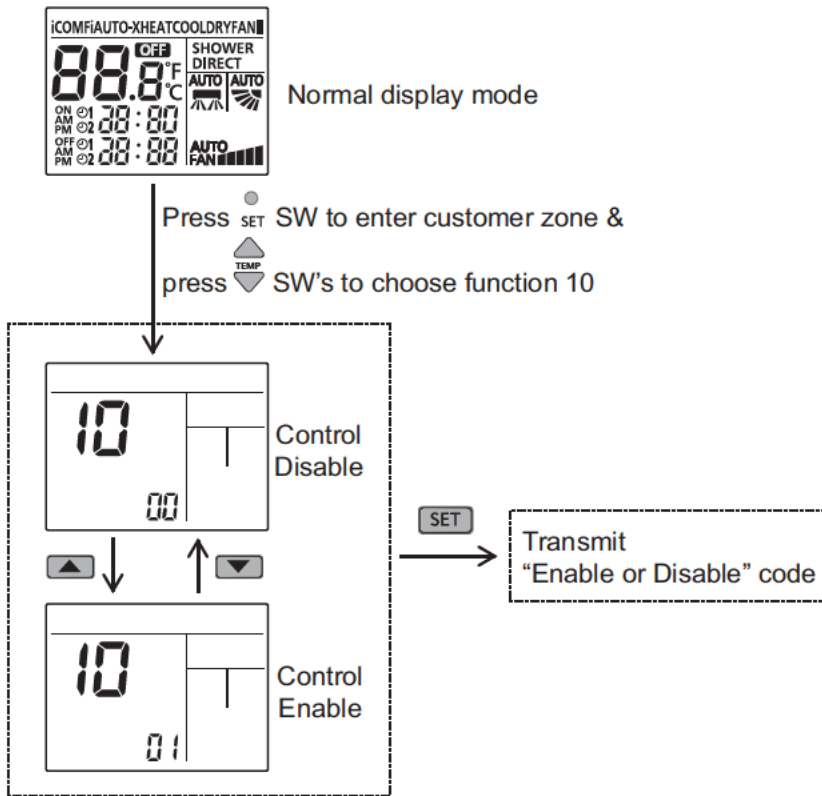

- ① Press SW, special setting is immediately cancelled and normal mode starts.
- ② If no SW is pressed for 30secs, then special setting mode is cancelled and normal mode starts.
- ③ Under this function, only , , , , & SW's are effective.

Note:
By default if enable.

14. Troubleshooting Guide

14.1 Refrigeration Cycle System

In order to diagnose malfunctions, make sure that there are no electrical problems before inspecting the refrigeration cycle. Such problems include insufficient insulation, problem with the power source, malfunction of a compressor and a fan. The normal outlet air temperature and pressure of the refrigeration cycle depends on various conditions, the standard values for them are shown in the table on the right.

Normal Pressure and Outlet Air Temperature (Standard)

	Gas pressure PSI (kg/cm ² G)	Outlet air temperature (°F)
Cooling Mode	130.53 ~ 174.04 (9 ~ 12)	53.6 ~ 60.8
Heating Mode	333.58 ~ 420.60 (23 ~ 29)	96.8 ~ 113

- *Condition:
- Indoor fan speed; High
 - Outdoor temperature 95°F at cooling mode and 44.6°F at heating mode
 - Compressor operates at rated frequency

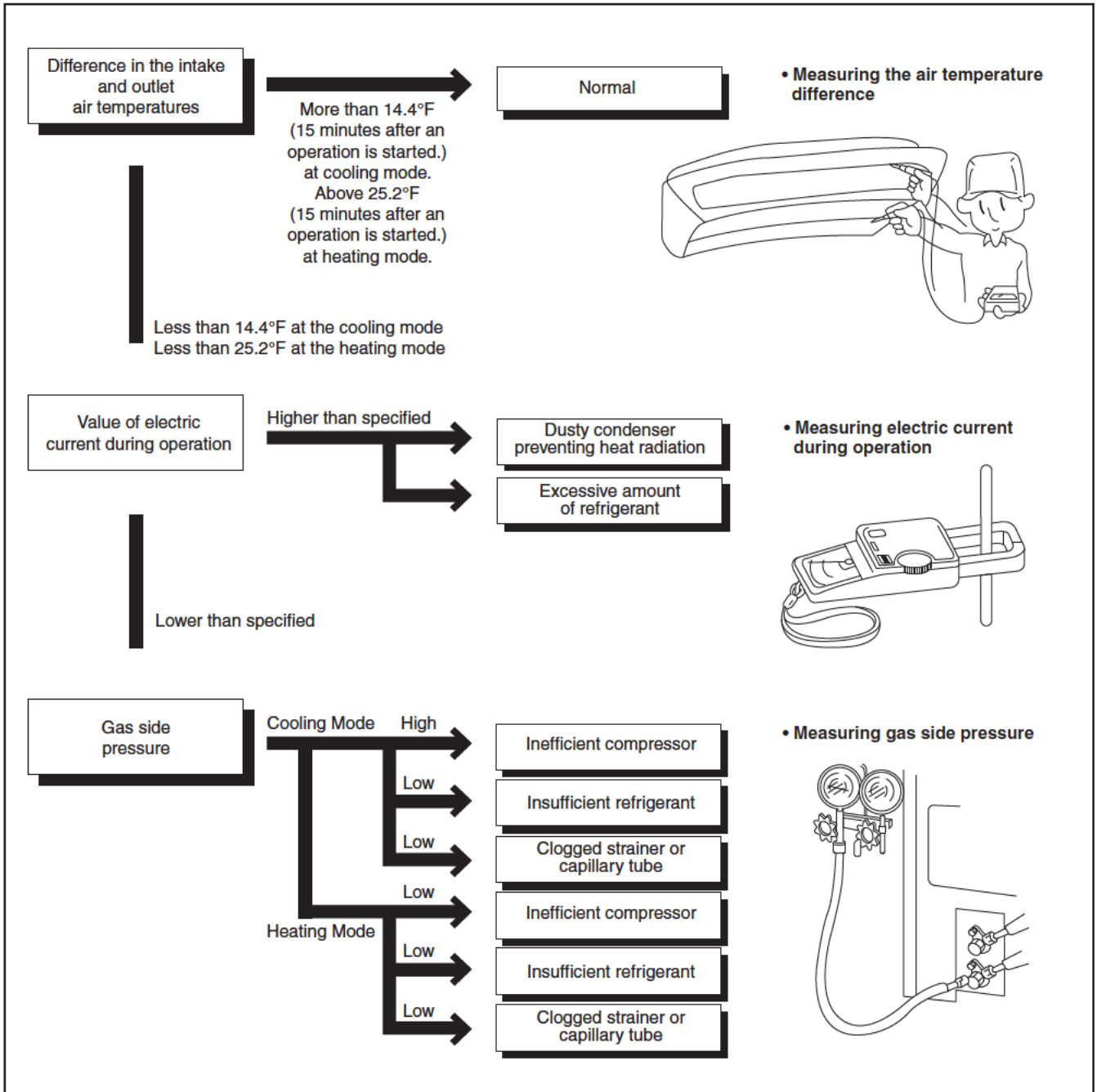

14.2 Relationship Between the Condition of the Air Conditioner and Pressure and Electric Current

Condition of the air conditioner	Cooling Mode			Heating Mode		
	Low Pressure	High Pressure	Electric current during operation	Low Pressure	High Pressure	Electric current during operation
Insufficient refrigerant (gas leakage)	↘	↘	↘	↘	↘	↘
Clogged capillary tube or Strainer	↘	↘	↘	↗	↗	↗
Short circuit in the indoor unit	↘	↘	↘	↗	↗	↗
Heat radiation deficiency of the outdoor unit	↗	↗	↗	↘	↘	↘
Inefficient compression	↗	↘	↘	↗	↘	↘

- Carry out the measurement of pressure, electric current, and temperature fifteen minutes after an operation is started.

14.3 Breakdown Self Diagnosis Function

14.3.1 Self Diagnosis Function (Three Digits Alphanumeric Code)

- Once abnormality has occurred during operation, the unit will stop its operation, and OFF/ON operation LED OFF.
- OFF indicator does not shown on remote control display.
- In operation after breakdown repair, the last error code abnormality will be stored in EEPROM.
- **To make a diagnosis**
 - 1 OFF/ON operation LED OFF and the unit automatically stops the operation, but the OFF indicator does not shown.
 - 2 Press CHECK button continuously for 5 seconds.
 - 3 “- -” will be displayed on the remote controller display.
 - 4 Press timer ▲ or ▼ button on the remote control. The error code “H00” (no abnormality) will be displayed.
 - 5 Every press of the button (▲ or ▼) will increase the error code number.
 - 6 When the displayed error code matches the unit’s error code, OFF/ON operation LED will be ON continuously.
 - 7 The breakdown diagnosis mode will be cancelled by pressing CHECK button continuously for 5 seconds or wait for 30 seconds.

- **AC Reset button**

When AC Reset button is pressed, the error code will be reset so that the unit will be able to operate and recheck if any error occurred.

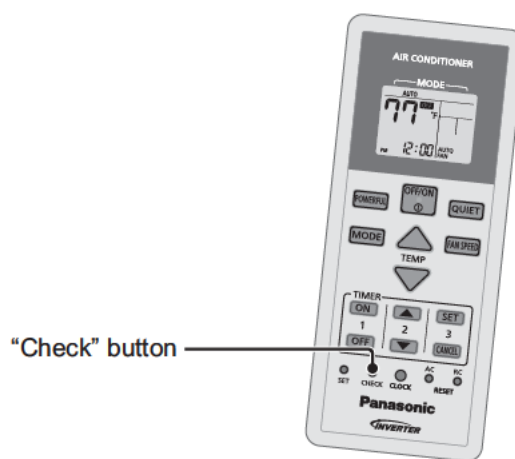

- **To display memorized error status:**

- 1 Turn ON the power supply.
- 2 Press CHECK button continuously for 5 seconds.
- 3 “- -” will be displayed on the remote controller display.
- 4 Press timer ▲ or ▼ button on the remote control. The error code “H00” (no abnormality) will be displayed.
- 5 Every press of the button (▲ or ▼) will increase the error code number.
- 6 When the displayed error code matches the unit’s error code, OFF/ON operation LED will be ON continuously.
- 7 The breakdown diagnosis mode will be cancelled by pressing CHECK button continuously for 5 seconds or wait for 30 seconds.

14.4 Error Codes Table

Diagnosis display	Abnormality / Protection control	Abnormality Judgment	Emergency Operation	Primary location to verify
H00	No abnormality detected	—	Normal operation	—
H11	Indoor/outdoor abnormal communication	> 1 min. after starting operation	Indoor fan operation only	<ul style="list-style-type: none"> • Internal/external cable connections • Indoor/Outdoor PCB
H12	Connection capability rank abnormal	—	—	—
H14	Indoor intake air temperature sensor abnormality	Continue for 5 sec.	—	<ul style="list-style-type: none"> • Intake air temperature sensor (defective or disconnected)
H15	Outdoor compressor temperature sensor abnormality	Continue for 5 sec.	—	<ul style="list-style-type: none"> • Compressor temperature sensor (defective or disconnected)
H16	Outdoor Current Transformer open circuit	—	—	<ul style="list-style-type: none"> • Outdoor PCB • IPM (Power transistor) module
H19	Indoor fan motor mechanism lock	—	—	<ul style="list-style-type: none"> • Indoor PCB • Fan motor
H21	Indoor float switch operation abnormal	—	—	—
H23	Indoor heat exchanger temperature sensor 1 abnormality	Continue for 5 sec.	O (Cooling only)	<ul style="list-style-type: none"> • Heat exchanger temperature sensor 1 (defective or disconnected)
H24	Indoor heat exchanger temperature sensor 2 abnormality	Continue for 5 sec.	—	<ul style="list-style-type: none"> • Heat exchanger temperature sensor 2 (defective or disconnected)
H27	Outdoor air temperature sensor abnormality	Continue for 5 sec.	O	<ul style="list-style-type: none"> • Outdoor temperature sensor (defective or disconnected)
H28	Outdoor heat exchanger temperature sensor abnormality	Continue for 5 sec.	O	<ul style="list-style-type: none"> • Outdoor heat exchanger temperature sensor (defective or disconnected)
H30	Discharge temperature sensor abnormality	Continue for 5 sec.	—	<ul style="list-style-type: none"> • Discharge temperature sensor
H32	Outdoor heat exchanger temperature sensor 2 abnormality	Continue for 5 sec.	—	<ul style="list-style-type: none"> • Discharge pipe temperature sensor (defective or disconnected).
H34	Outdoor heat sink temperature sensor abnormality	Continue for 2 sec.	—	<ul style="list-style-type: none"> • Outdoor heat sink temperature sensor (defective or disconnected).
H35	Indoor drain water adverse current abnormal	—	—	—
H36	Gas pipe temperature sensor abnormality	Continue for 5 sec.	—	<ul style="list-style-type: none"> • Gas pipe temperature sensor (defective or disconnected).
H37	Outdoor liquid pipe temperature sensor abnormality	Continue for 2 sec.	—	<ul style="list-style-type: none"> • Outdoor liquid pipe temperature sensor (defective or disconnected).
H39	Abnormal indoor operating unit or standby units	—	—	—
H41	Wiring or piping connection abnormality	3 minutes after compressor start up	—	—
H97	Outdoor Fan Motor lock abnormality	2 times occurrence within 30 minutes	—	<ul style="list-style-type: none"> • Outdoor PCB • Outdoor Fan Motor
H98	Indoor high pressure protection	—	—	<ul style="list-style-type: none"> • Air filter dirty • Air circulation short circuit
H99	Indoor heat exchanger anti-freezing protection	—	—	<ul style="list-style-type: none"> • Insufficient refrigerant • Air filter dirty
F11	Cooling / Heating cycle changeover abnormality	4 times occurrence within 30 minutes	—	<ul style="list-style-type: none"> • 4-way valve • V-coil
F17	Indoor unit freezing error	3 times occurrence within 30 minutes	—	<ul style="list-style-type: none"> • Expansion valve leakage • Indoor unit pipe temperature sensor (check for changes in characteristics and check its resistance)
F90	PFC control	4 times occurrence within 10 minutes	—	<ul style="list-style-type: none"> • Voltage at PFC
F91	Refrigeration cycle abnormality	2 times occurrence within 20 minutes	—	<ul style="list-style-type: none"> • No refrigerant (3-way valve is closed)
F93	Outdoor compressor abnormal revolution	4 times occurrence within 20 minutes	—	<ul style="list-style-type: none"> • Outdoor compressor
F95	Cool high pressure protection	4 times occurrence within 20 minutes	—	<ul style="list-style-type: none"> • Outdoor refrigerant circuit
F96	IPM (power transistor) overheating protection	—	—	<ul style="list-style-type: none"> • Excess refrigerant • Improper heat radiation • IPM (Power transistor)
F97	Outdoor compressor overheating protection	4 times occurrence within 20 minutes	—	<ul style="list-style-type: none"> • Insufficient refrigerant • Compressor

Diagnosis display	Abnormality / Protection control	Abnormality Judgment	Emergency Operation	Primary location to verify
F98	Total running current protection	3 times occurrence within 20 minutes	—	<ul style="list-style-type: none"> • Excess refrigerant • Improper heat radiation
F99	Outdoor Direct Current (DC) peak detection	7 times occurrence continuously	—	<ul style="list-style-type: none"> • Outdoor PCB • IPM (Power transistor) • Compressor

Note:

“O” - Frequency measured and fan speed fixed.

The memory data of error code is erased when the power supply is cut off, or press the Auto Switch until “beep” sound heard following by pressing the “CHECK” button at Remote Control.

Although operation forced to stop when abnormality detected, emergency operation is possible for certain errors (refer to Error Codes Table) by using Remote Control or Auto Switch at indoor unit. However, the Remote Control signal receiving sound is changed from one “beep” to four “beep” sounds.

14.5 Self-diagnosis Method

14.5.1 H11 (Indoor/Outdoor Abnormal Communication)

Malfunction Decision Conditions

- During startup and operation of cooling and heating, the data received from outdoor unit in indoor unit signal transmission is checked whether it is normal.

Malfunction Caused

- Faulty indoor unit PCB.
- Faulty outdoor unit PCB.
- Indoor unit-outdoor unit signal transmission error due to wiring error.
- Indoor unit-outdoor unit signal transmission error due to breaking of wire in the connection wires between the indoor and outdoor units.

Troubleshooting

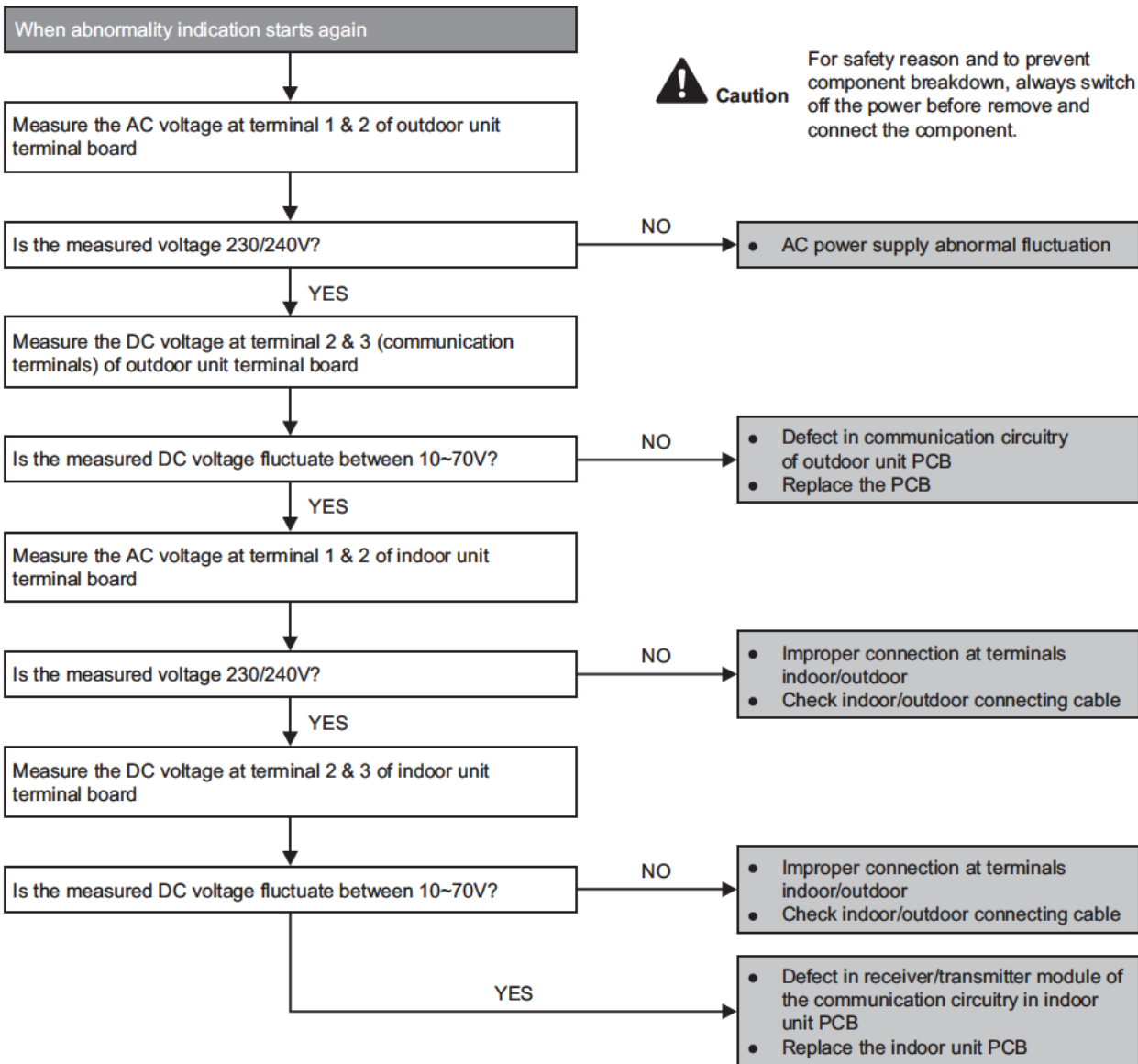

14.5.2 H12 (Indoor/Outdoor Capacity Rank Mismatched)

Malfunction Decision Conditions

- During startup, error code appears when different types of indoor and outdoor units are interconnected.

Malfunction Caused

- Wrong models interconnected.
- Wrong indoor unit or outdoor unit PCBs mounted.
- Indoor unit or outdoor unit PCBs defective.
- Indoor-outdoor unit signal transmission error due to wrong wiring.
- Indoor-outdoor unit signal transmission error due to breaking of wire 3 in the connection wires between the indoor and outdoor units.

Troubleshooting

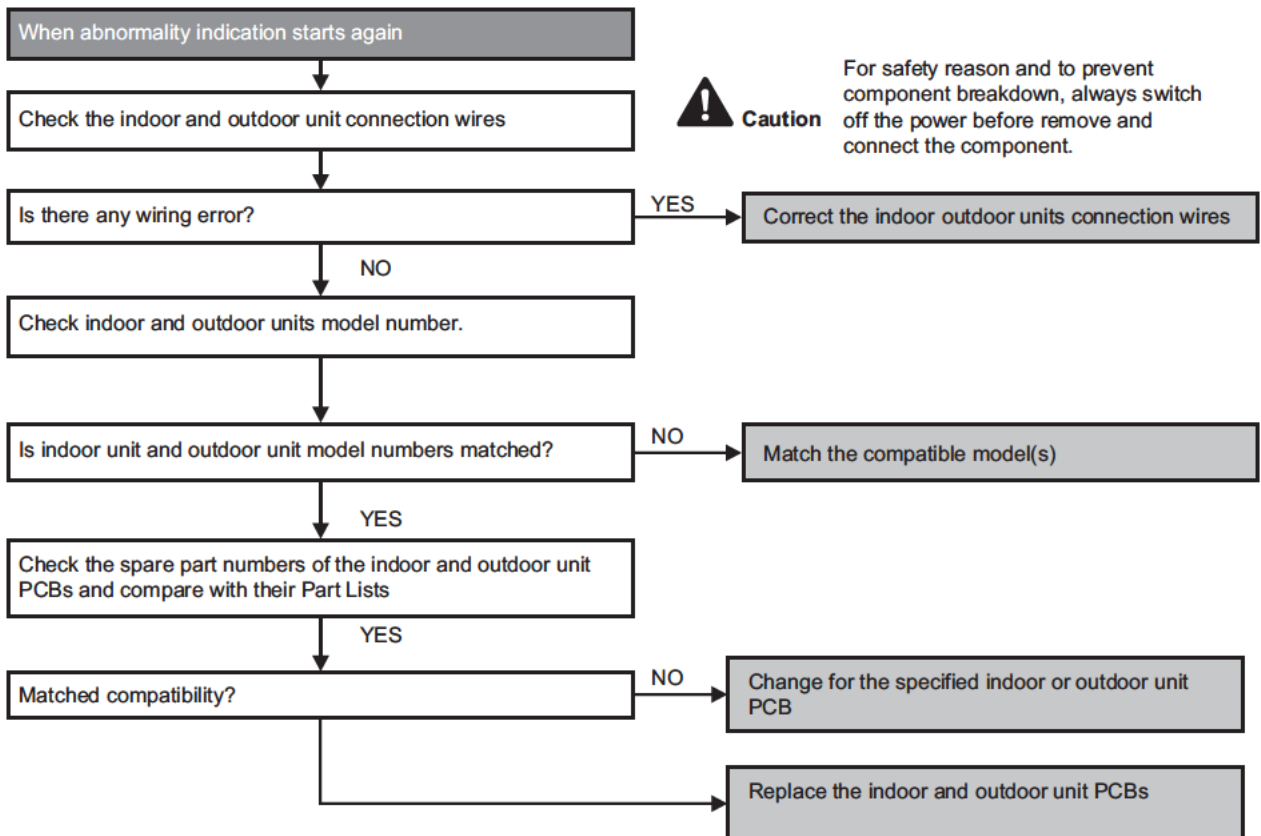

14.5.3 H14 (Indoor Intake Air Temperature Sensor Abnormality)

Malfunction Decision Conditions

- During startup and operation of cooling and heating, the temperatures detected by the indoor intake air temperature sensor are used to determine sensor errors.

Malfunction Caused

- Faulty connector connection.
- Faulty sensor.
- Faulty PCB.

Troubleshooting

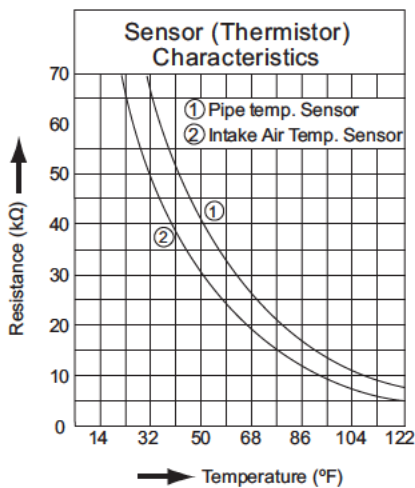
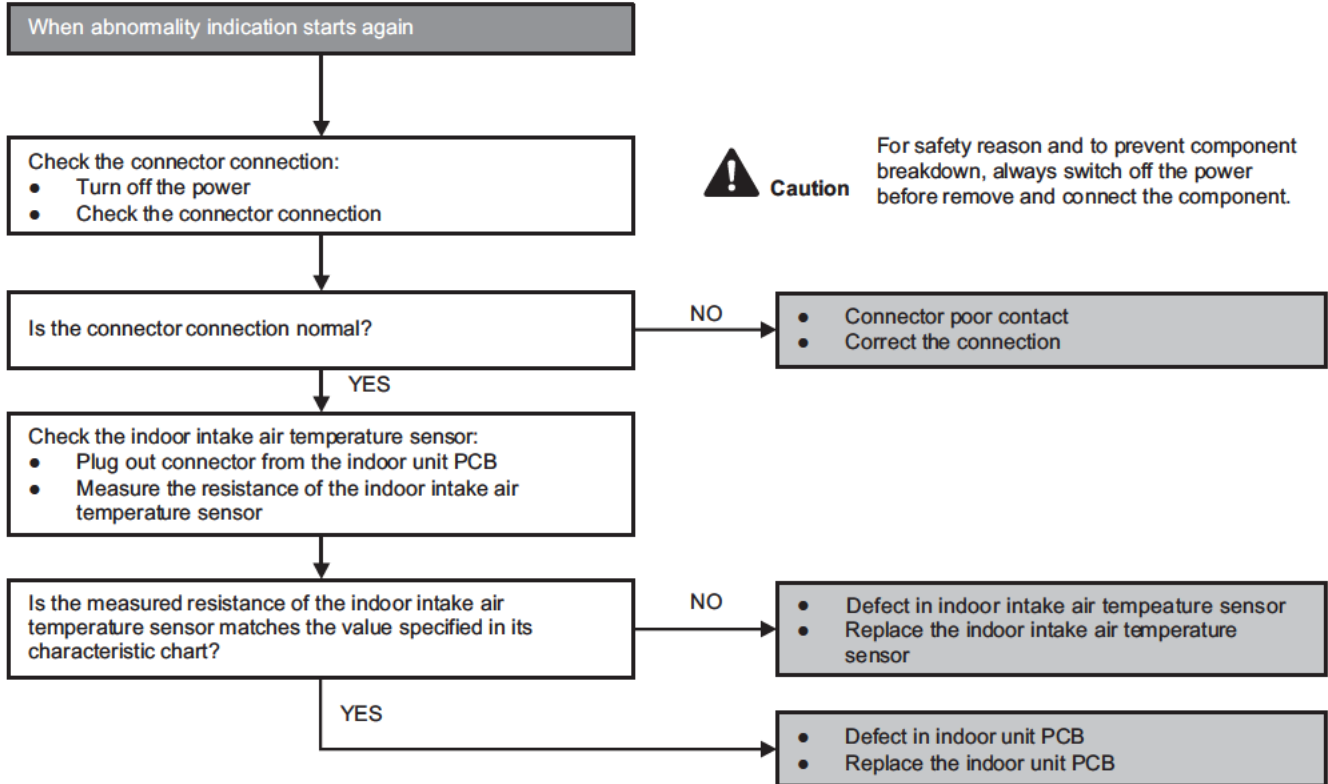

14.5.4 H15 (Compressor Temperature Sensor Abnormality)

Malfunction Decision Conditions

- During startup and operation of cooling and heating, the temperatures detected by the outdoor compressor temperature sensor are used to determine sensor errors.

Malfunction Caused

- Faulty connector connection.
- Faulty sensor.
- Faulty PCB.

Troubleshooting

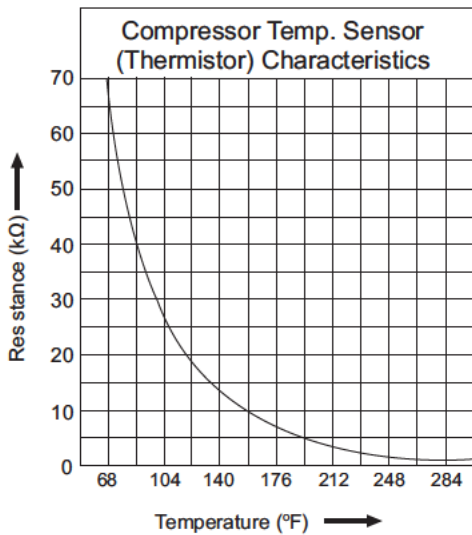
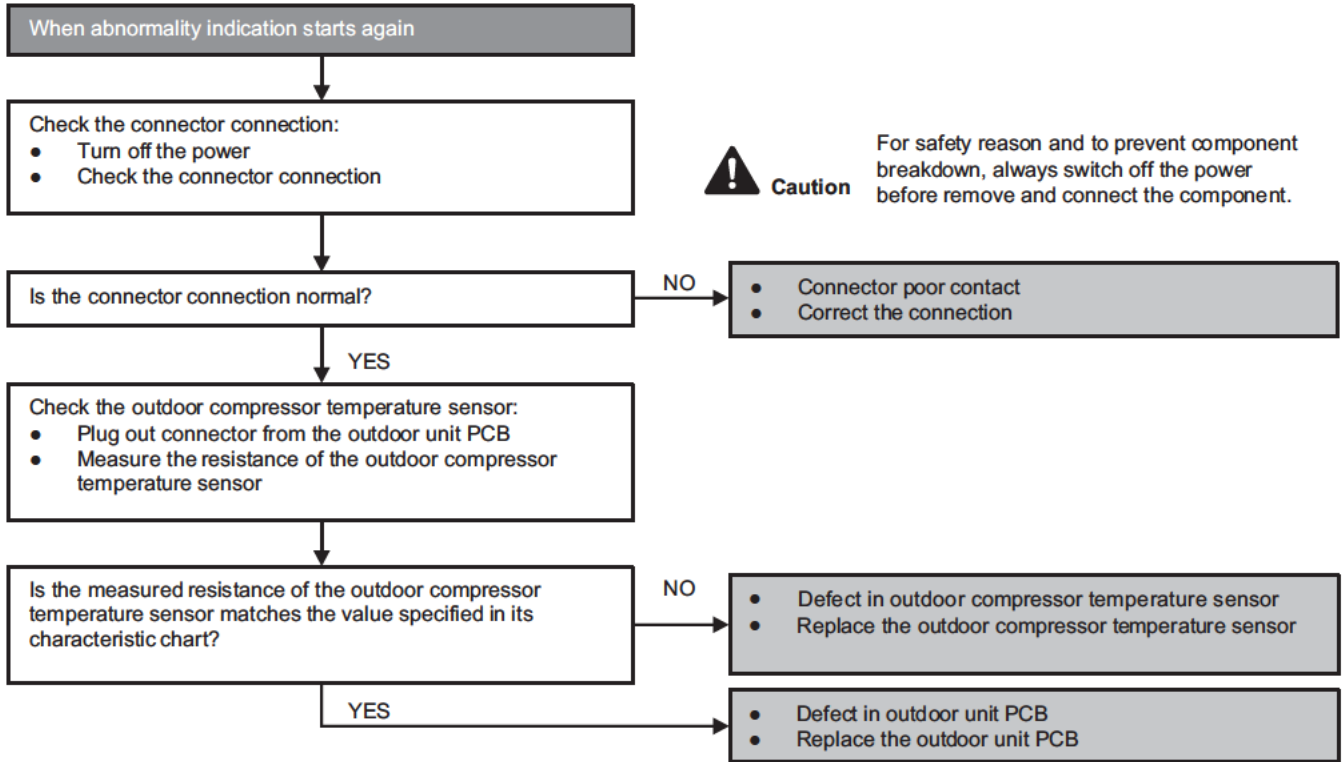

14.5.5 H16 (Outdoor Current Transformer)

Malfunction Decision Conditions

- An input current, detected by Current Transformer CT, is below threshold value when the compressor is operating at certain frequency value for 3 minutes.

Malfunction Caused

- Lack of gas
- Broken CT (current transformer)
- Broken Outdoor PCB

Troubleshooting

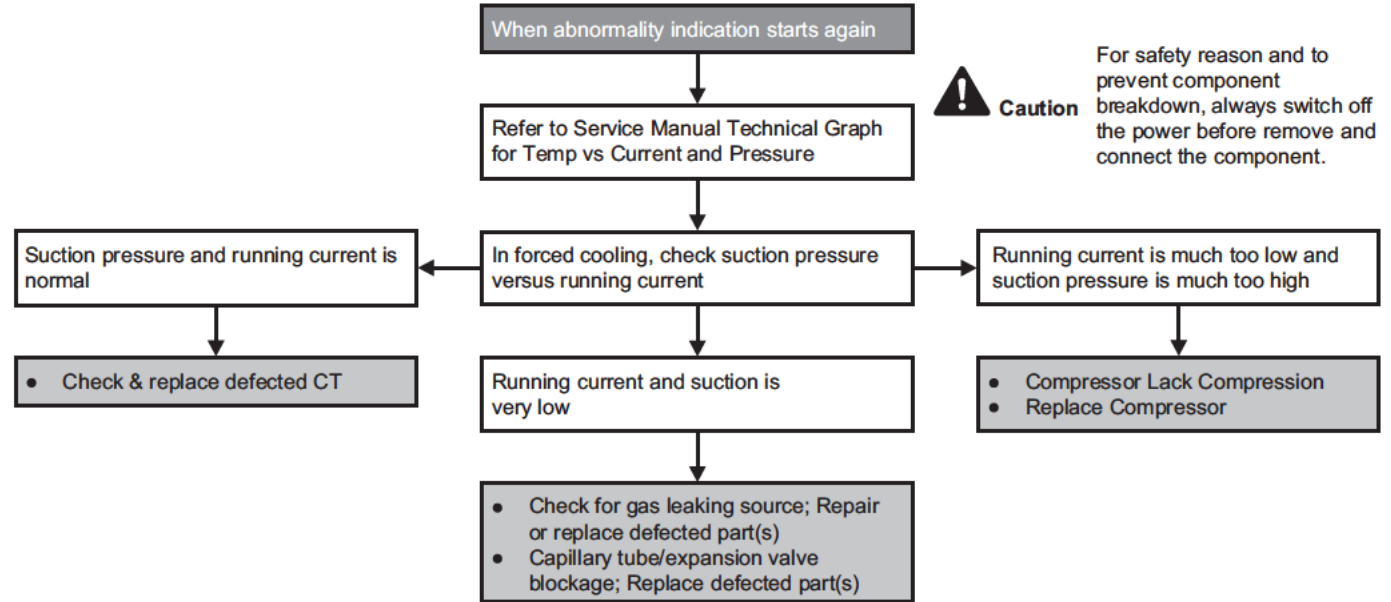

14.5.6 H19 (Indoor Fan Motor – DC Motor Mechanism Locked)

Malfunction Decision Conditions

- The rotation speed detected by the Hall IC during fan motor operation is used to determine abnormal fan motor (feedback of rotation > 2550 rpm or < 50 rpm)

Malfunction Caused

- Operation stops due to short circuit inside the fan motor winding.
- Operation stops due to breaking of wire inside the fan motor.
- Operation stops due to breaking of fan motor lead wires.
- Operation stops due to Hall IC malfunction.
- Operation error due to faulty indoor unit PCB.

Troubleshooting

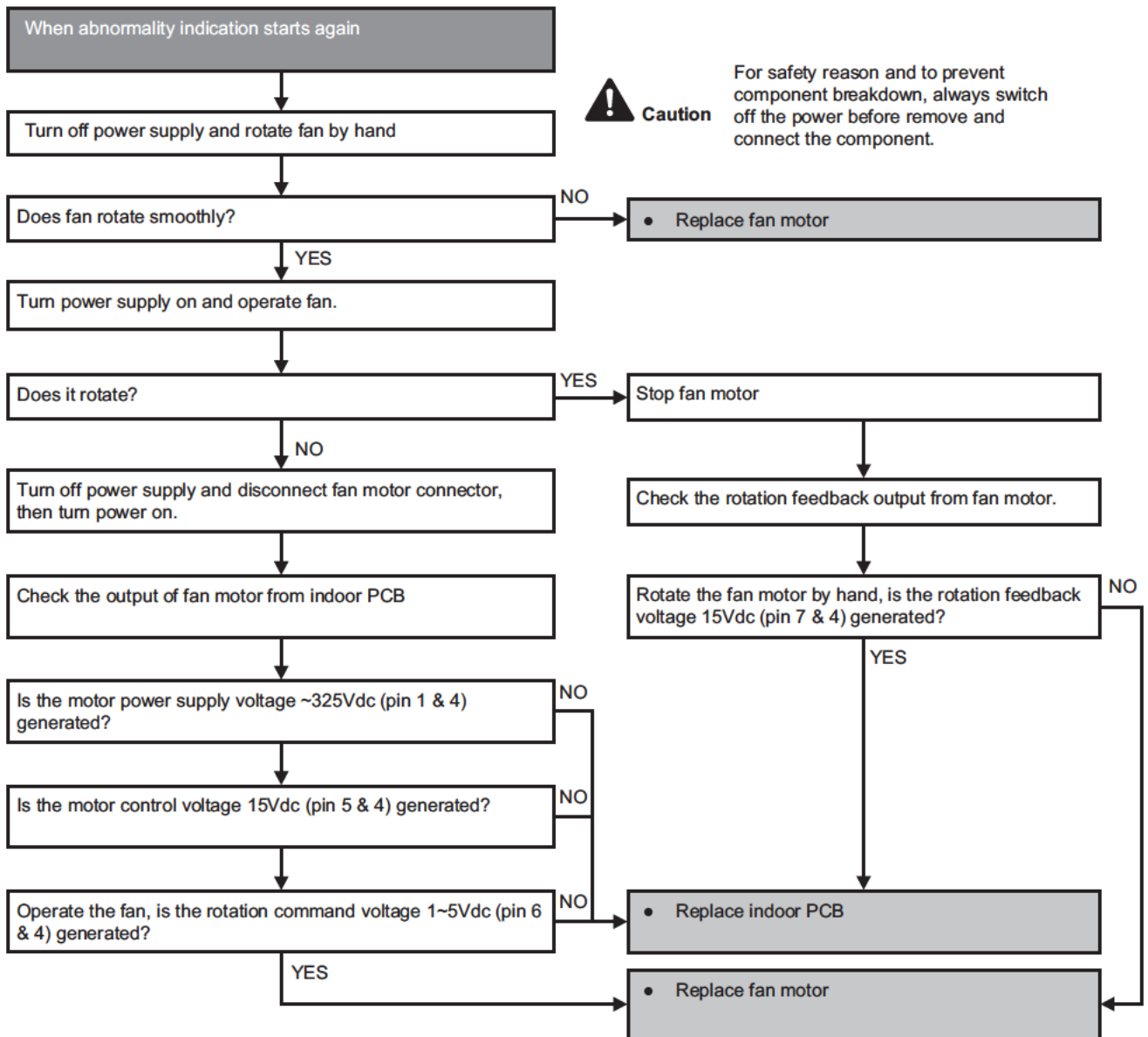

14.5.7 H23 (Indoor Pipe Temperature Sensor Abnormality)

Malfunction Decision Conditions

- During startup and operation of cooling and heating, the temperatures detected by the indoor heat exchanger temperature sensor are used to determine sensor errors.

Malfunction Caused

- Faulty connector connection.
- Faulty sensor.
- Faulty PCB.

Troubleshooting

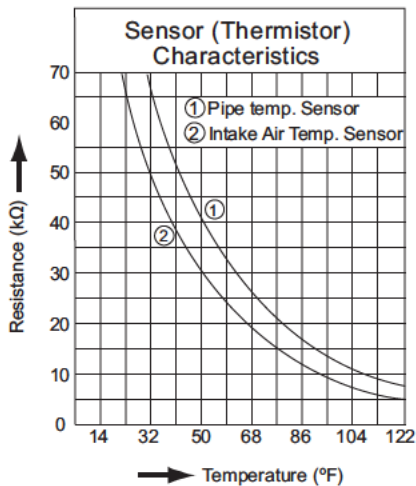
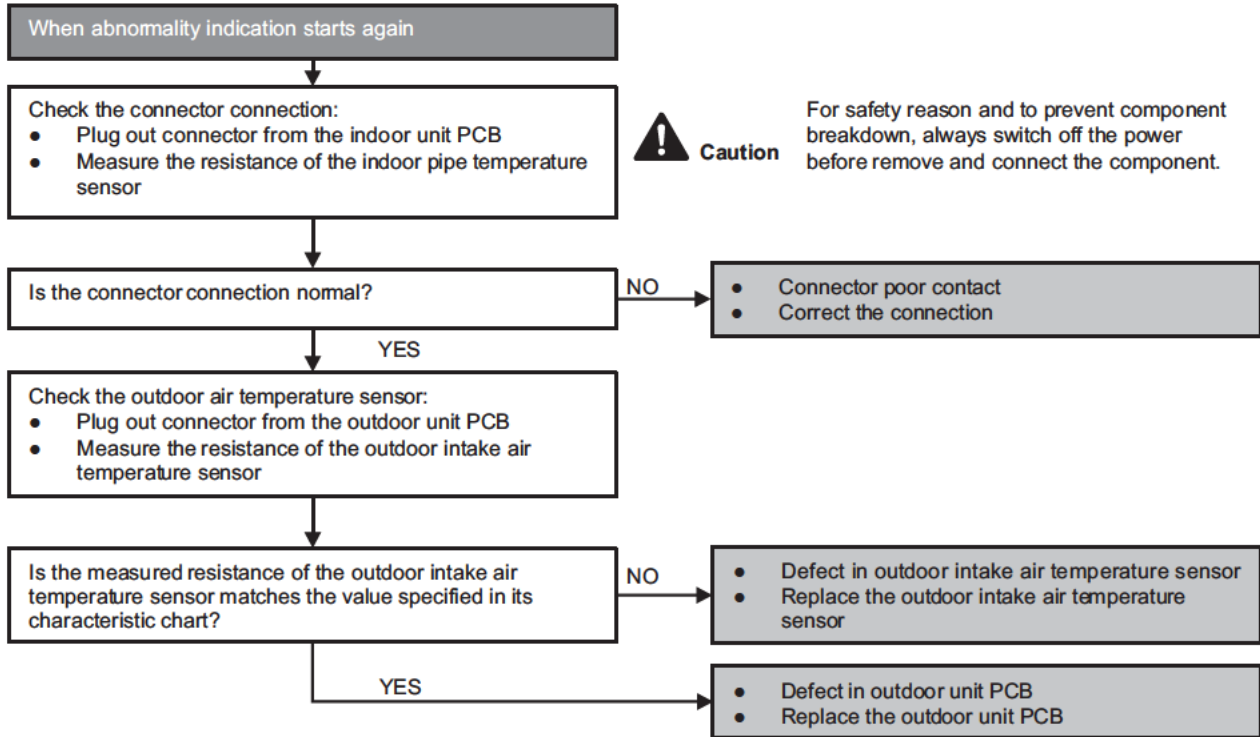

14.5.8 H24 (Indoor Pipe Temperature Sensor 2 Abnormality)

Malfunction Decision Conditions

- During startup and operation of cooling and heating, the temperatures detected by the indoor heat exchanger temperature sensor 2 are used to determine sensor errors.

Malfunction Caused

- Faulty connector connection.
- Faulty sensor.
- Faulty PCB.

Troubleshooting

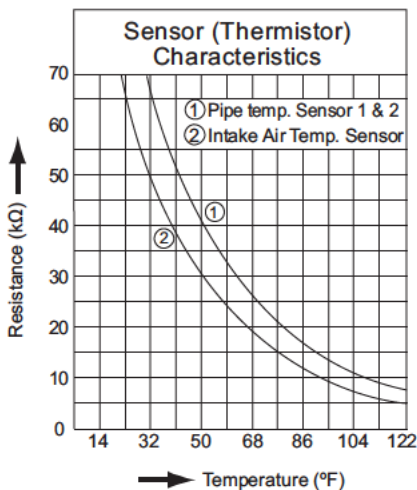
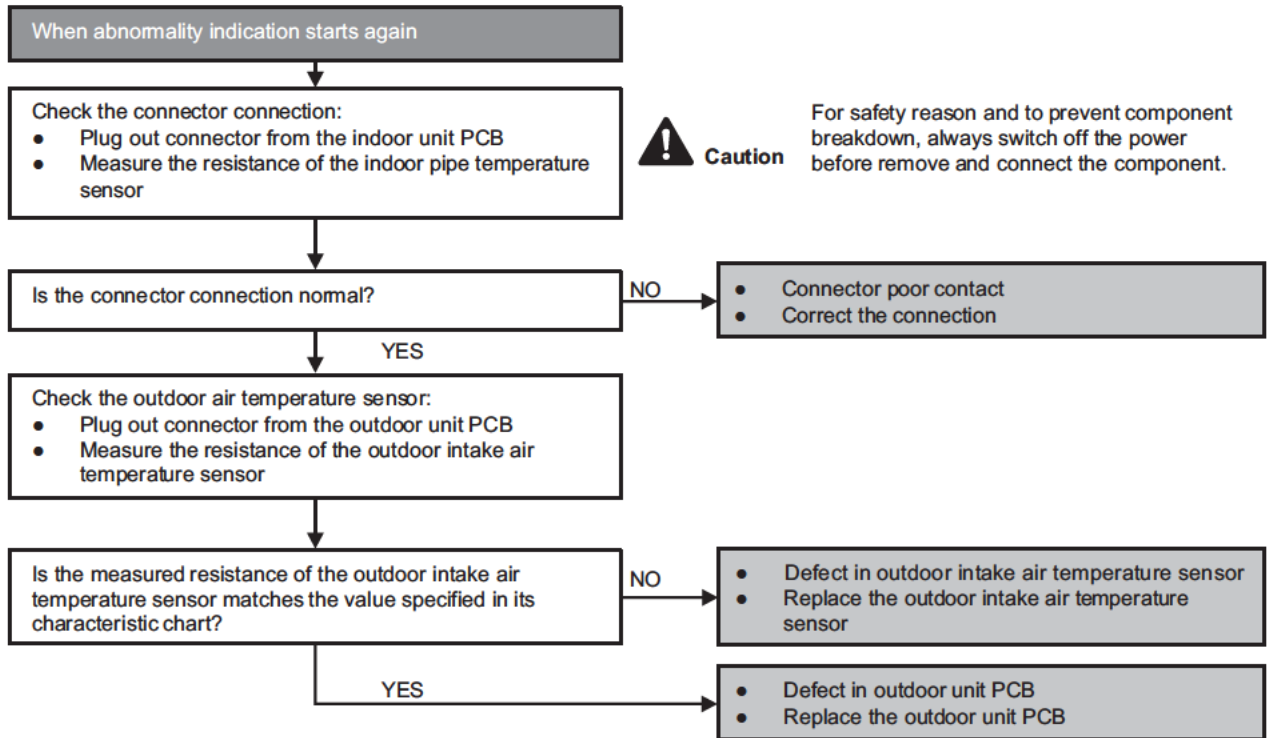

14.5.9 H27 (Outdoor Air Temperature Sensor Abnormality)

Malfunction Decision Conditions

- During startup and operation of cooling and heating, the temperatures detected by the outdoor air temperature sensor are used to determine sensor errors.

Malfunction Caused

- Faulty connector connection.
- Faulty sensor.
- Faulty PCB.

Troubleshooting

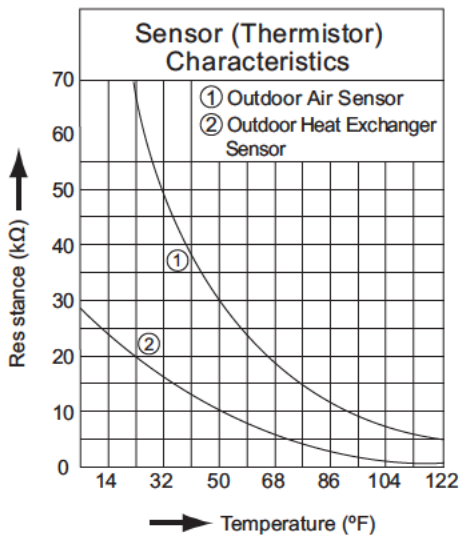
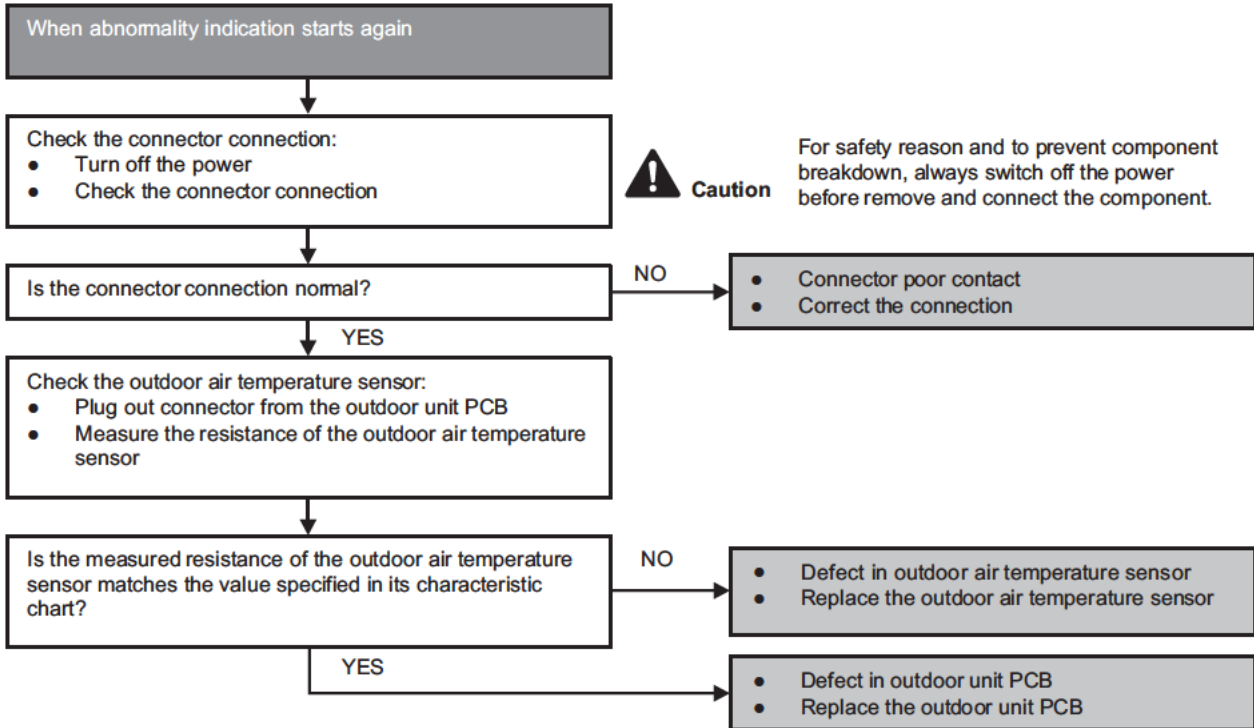

14.5.10 H28 (Outdoor Pipe Temperature Sensor Abnormality)

Malfunction Decision Conditions

- During startup and operation of cooling and heating, the temperatures detected by the outdoor pipe temperature sensor are used to determine sensor errors.

Malfunction Caused

- Faulty connector connection.
- Faulty sensor.
- Faulty PCB.

Troubleshooting

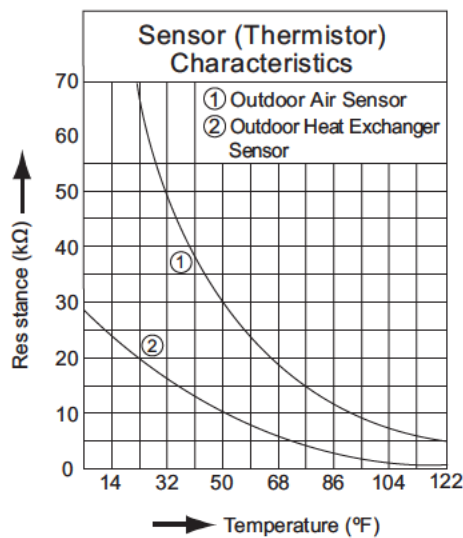
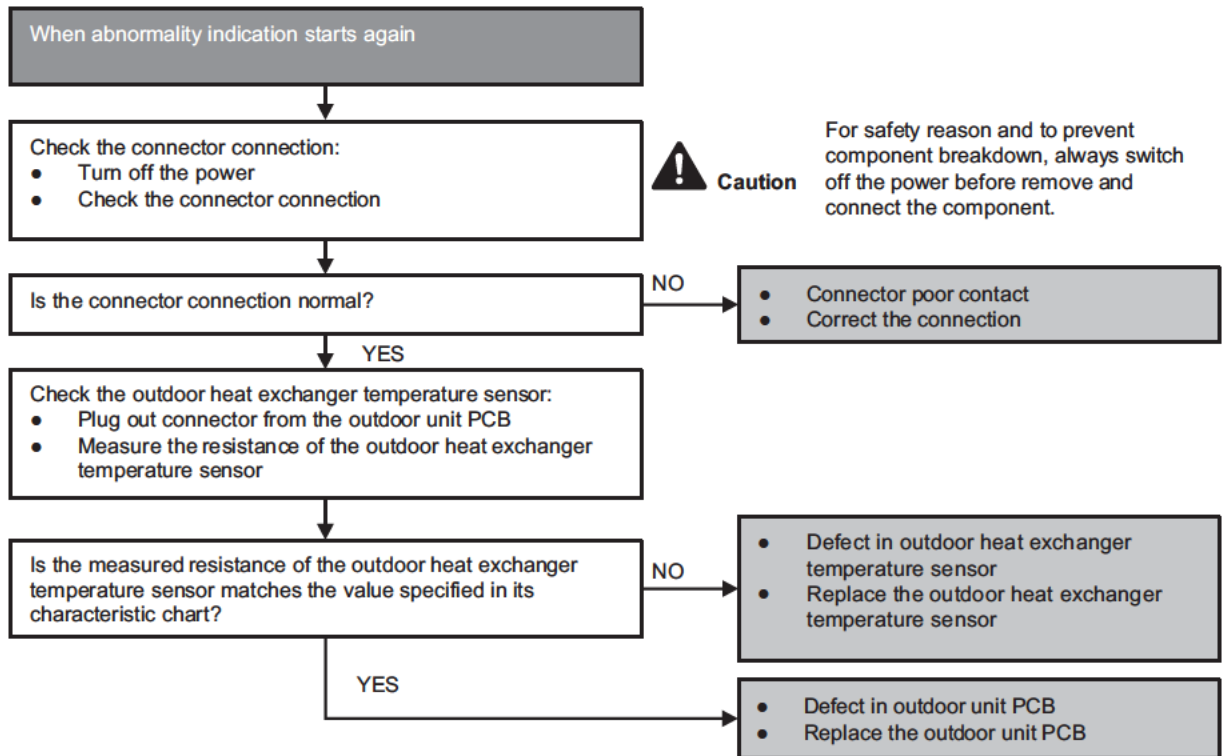

14.5.11 H30 (Compressor Discharge Temperature Sensor Abnormality)

Malfunction Decision Conditions

- During startup and operation of cooling and heating, the temperatures detected by the outdoor discharge pipe temperature sensor are used to determine sensor errors.

Malfunction Caused

- Faulty connector connection.
- Faulty sensor.
- Faulty PCB.

Troubleshooting

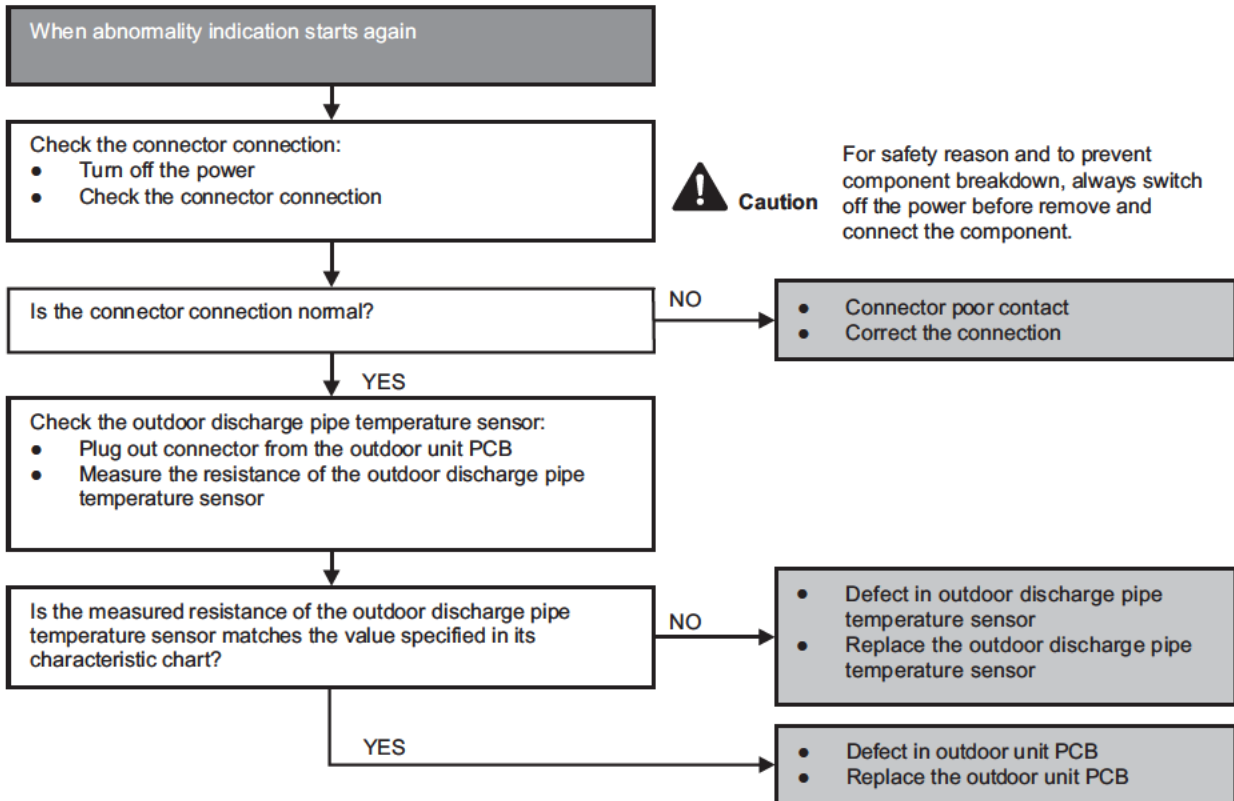

14.5.12 H33 (Unspecified Voltage between Indoor and Outdoor)

Malfunction Decision Conditions

- The supply power is detected for its requirement by the indoor/outdoor transmission.

Malfunction Caused

- Wrong models interconnected.
- Wrong indoor unit and outdoor unit PCBs used.
- Indoor unit or outdoor unit PCB defective.

Troubleshooting

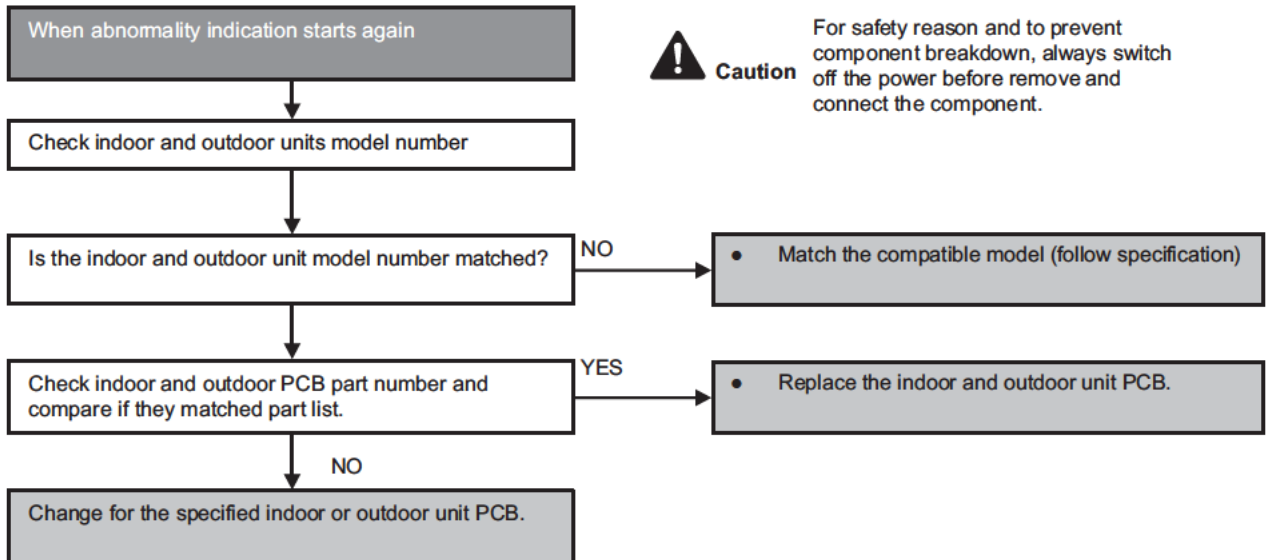

14.5.13 H97 (Outdoor Fan Motor – DC Motor Mechanism Locked)

Malfunction Decision Conditions

- The rotation speed detected by the Hall IC during fan motor operation is used to determine abnormal fan motor.

Malfunction Caused

- Operation stops due to short circuit inside the fan motor winding.
- Operation stops due to breaking of wire inside the fan motor.
- Operation stops due to breaking of fan motor lead wires.
- Operation stops due to Hall IC malfunction.
- Operation error due to faulty outdoor unit PCB.

Troubleshooting

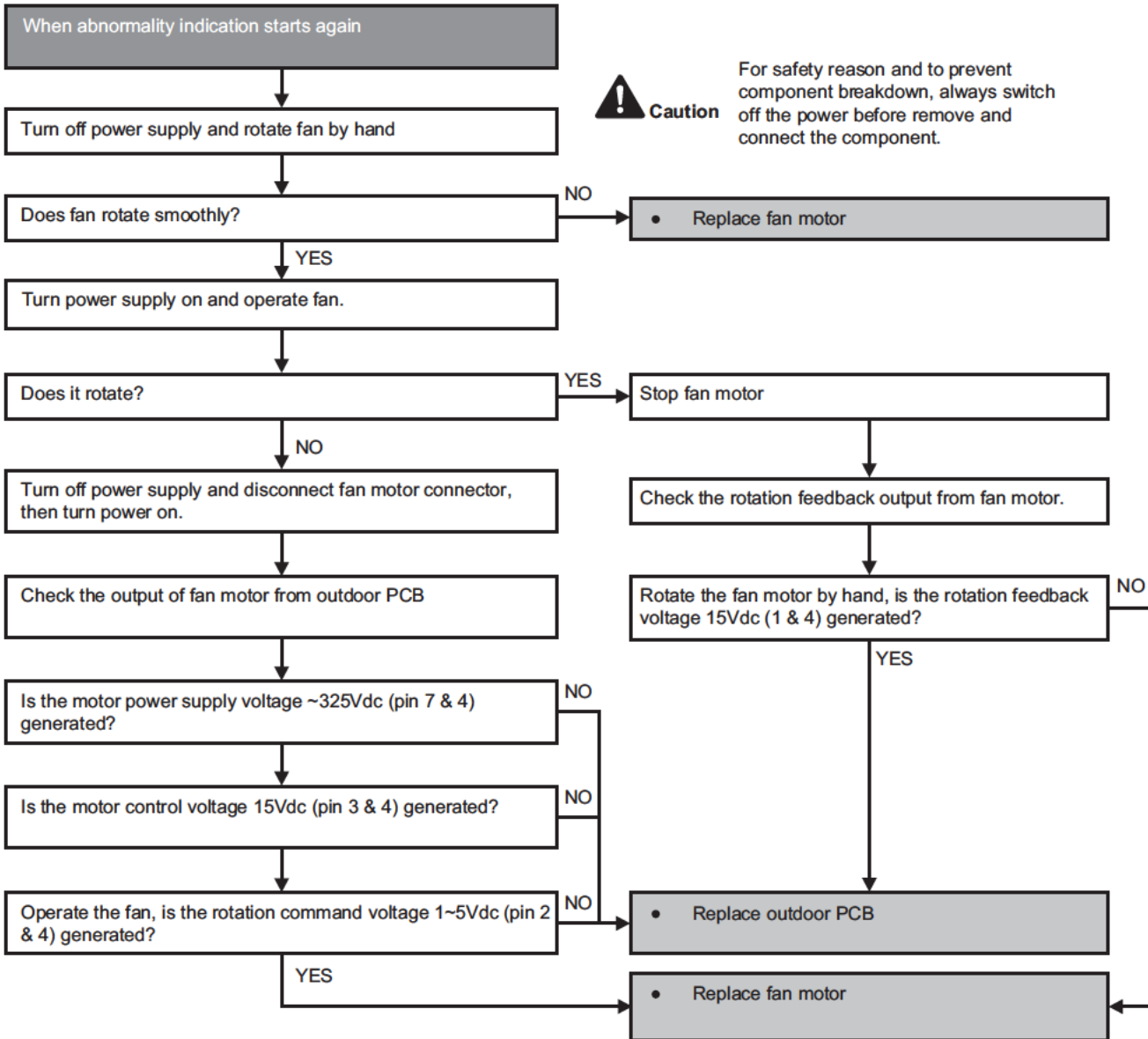

14.5.14 H98 (Error Code Stored in Memory and no alarm is triggered / no TIMER LED flashing)

Malfunction Decision Conditions

- Indoor high pressure is detected when indoor heat exchanger is detecting very high temperature when the unit is operating in heating operation.
- Phenomena: unit is stopping and re-starting very often in heating mode.

Malfunction Caused

- Indoor heat exchanger thermistor
- Clogged air filter or heat exchanger
- Over-bent pipe (liquid side)

Troubleshooting

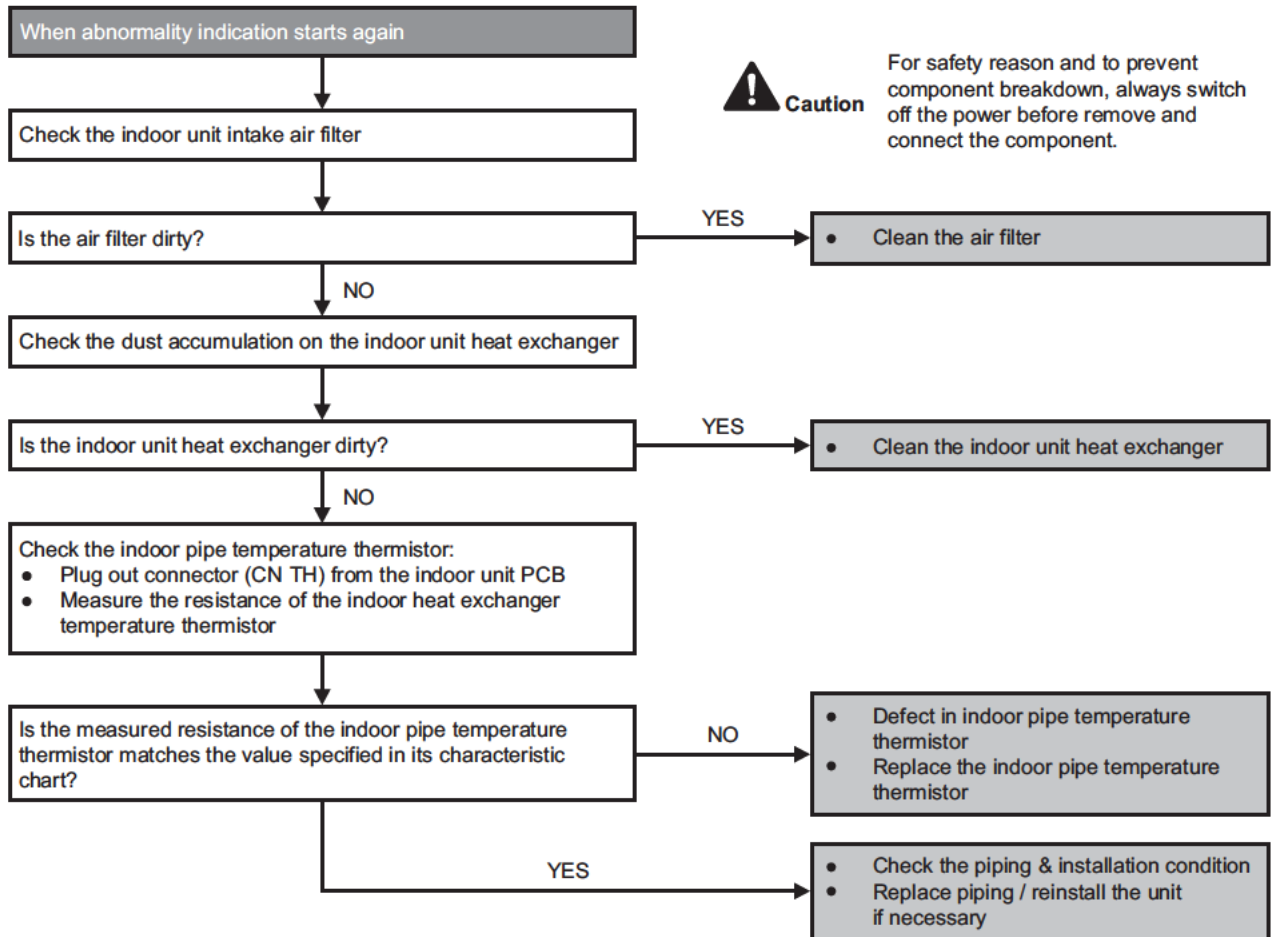

14.5.15 H99 (Indoor Freeze Prevention Protection: Cooling or Soft Dry)

Error Code will not display (no Timer LED blinking) but store in EEPROM

Malfunction Decision Conditions

- Freeze prevention control takes place (when indoor pipe temperature is lower than 35.6°F)

Malfunction Caused

- Air short circuit at indoor unit
- Clogged indoor unit air filter
- Dust accumulation on the indoor unit heat exchanger
- 2/3 way valve closed
- Faulty indoor unit fan motor
- Refrigerant shortage (refrigerant leakage)
- Clogged expansion valve or strainer
- Faulty indoor pipe temperature sensor
- Faulty indoor unit PCB

Troubleshooting

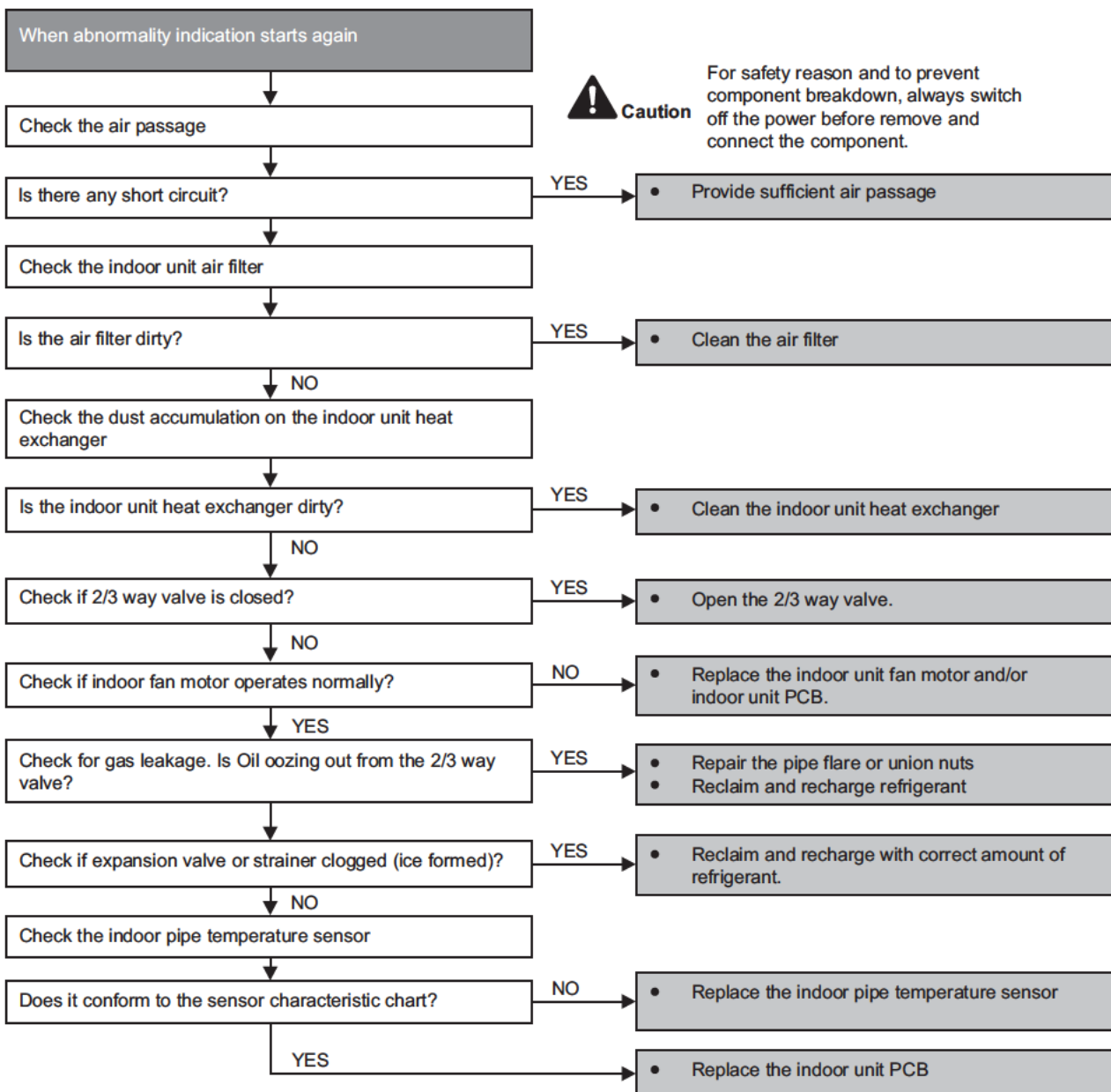

14.5.16 F11 (4-way Valve Switching Failure)

Malfunction Decision Conditions

- When indoor heat exchanger is cold during heating (except deice) or when indoor heat exchanger is hot during cooling and compressor operating, the 4-way valve is detected as malfunction.

Malfunction Caused

- Indoor heat exchanger (pipe) thermistor
- 4-way valve malfunction

Troubleshooting

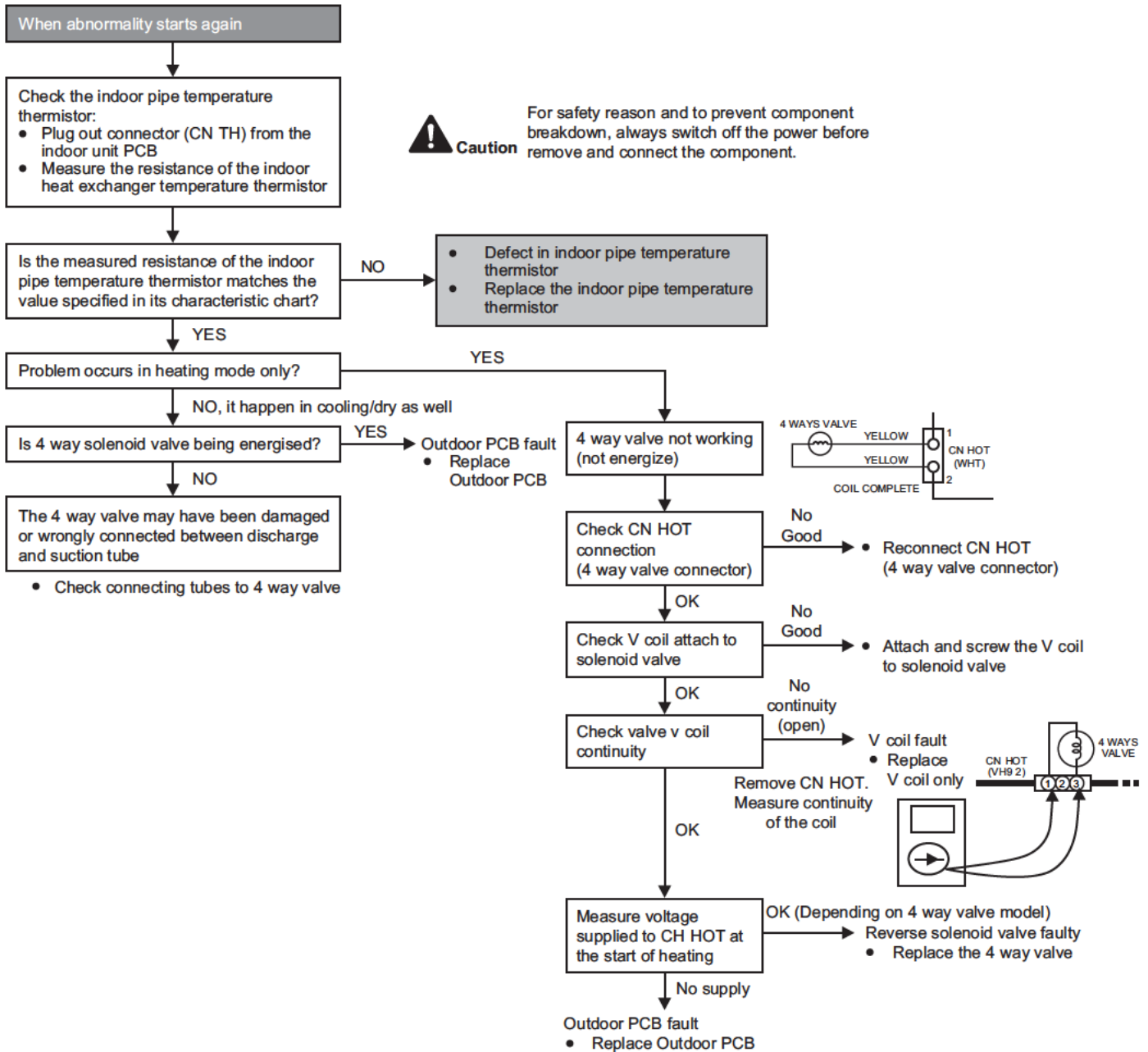

* Check gas side pipe – for hot gas flow in cooling mode

14.5.17 F90 (Power Factor Correction Protection)

Malfunction Decision Conditions

- To maintain DC voltage level supply to power transistor.
- To detect high DC voltage level after rectification.

Malfunction Caused

- During startup and operation of cooling and heating, when Power Factor Correction (PFC) protection circuitry at the outdoor unit main PCB senses abnormal DC voltage level for power transistors.
- When DC voltage detected is LOW, transistor switching will turn ON by controller to push-up the DC level.
- When DC voltage detected is HIGH (391Vdc – 425Vdc), active LOW signal will send by the controller to turn OFF relay RY-C.

Troubleshooting

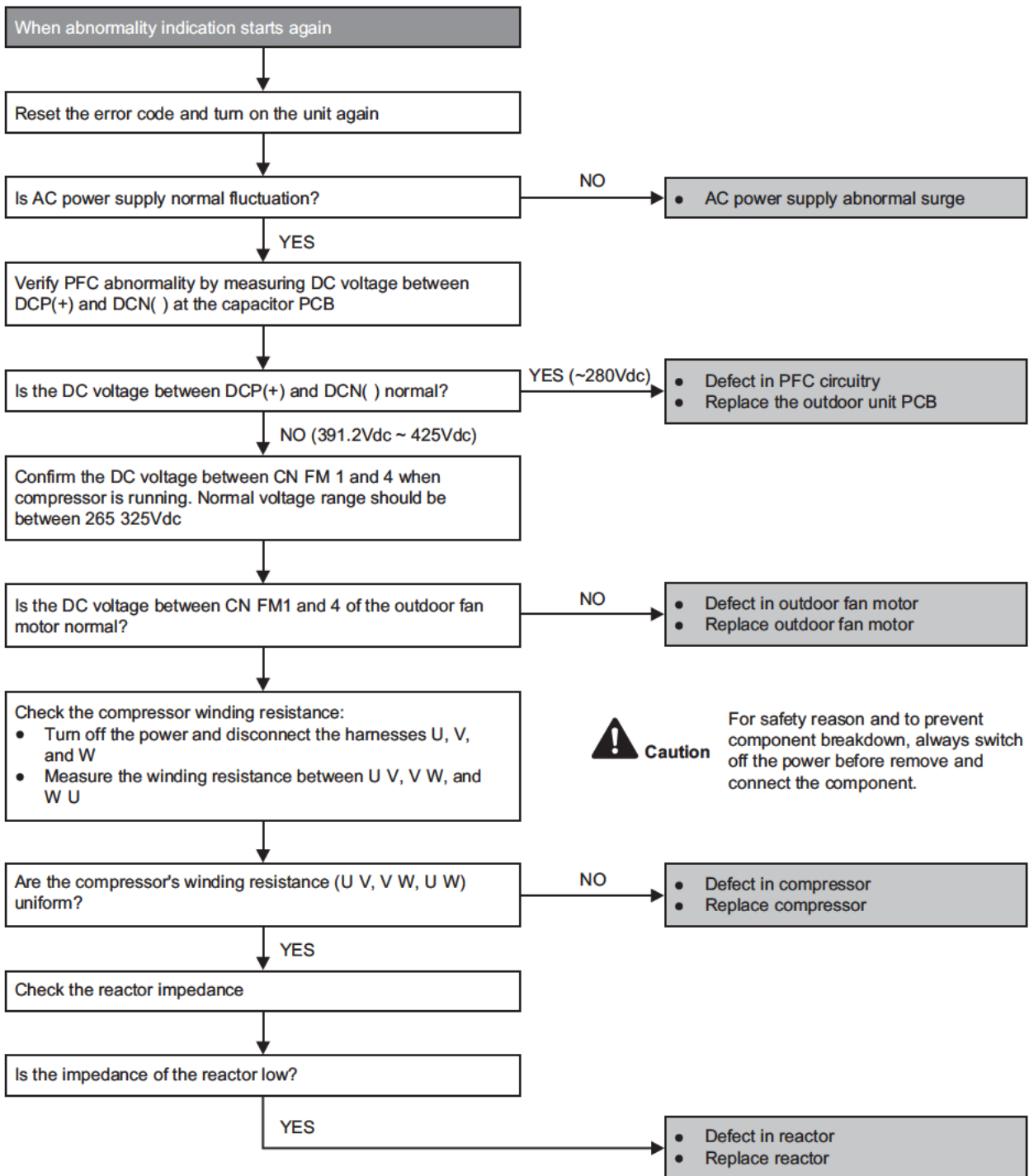

14.5.18 F91 (Refrigeration Cycle Abnormality)

Malfunction Decision Conditions

- The input current is low while the compressor is running at higher than the setting frequency.

Malfunction Caused

- Lack of gas.
- 3-way valve close.

Troubleshooting

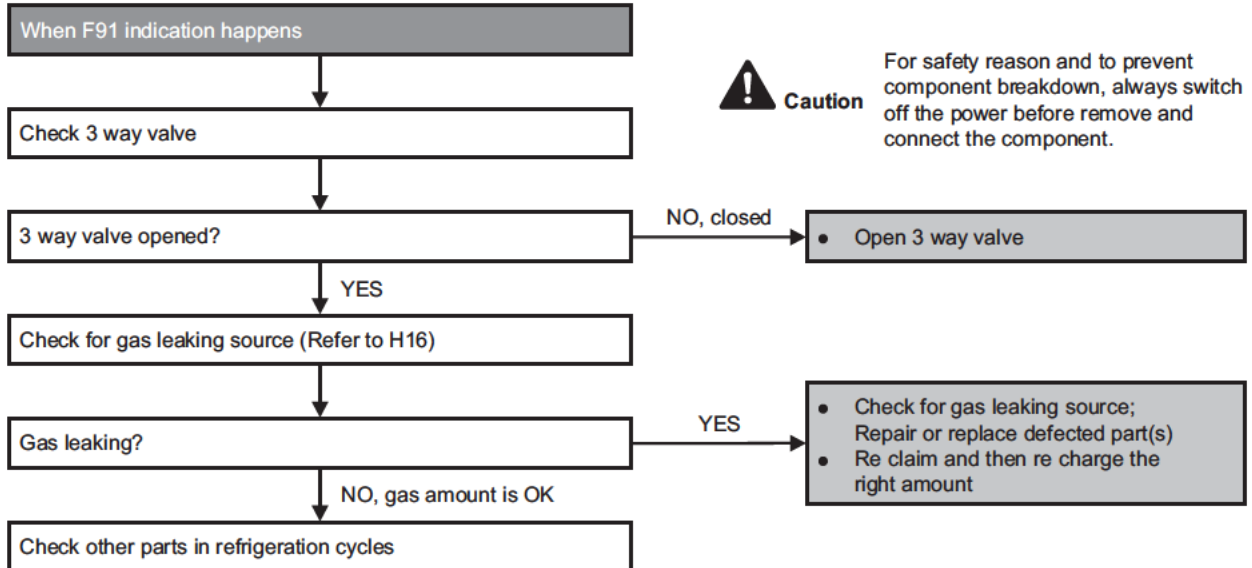

14.5.19 F93 (Compressor Rotation Failure)

Malfunction Decision Conditions

- A compressor rotation failure is detected by checking the compressor running condition through the position detection circuit.

Malfunction Caused

- Compressor terminal disconnect
- Faulty Outdoor PCB
- Faulty compressor

Troubleshooting

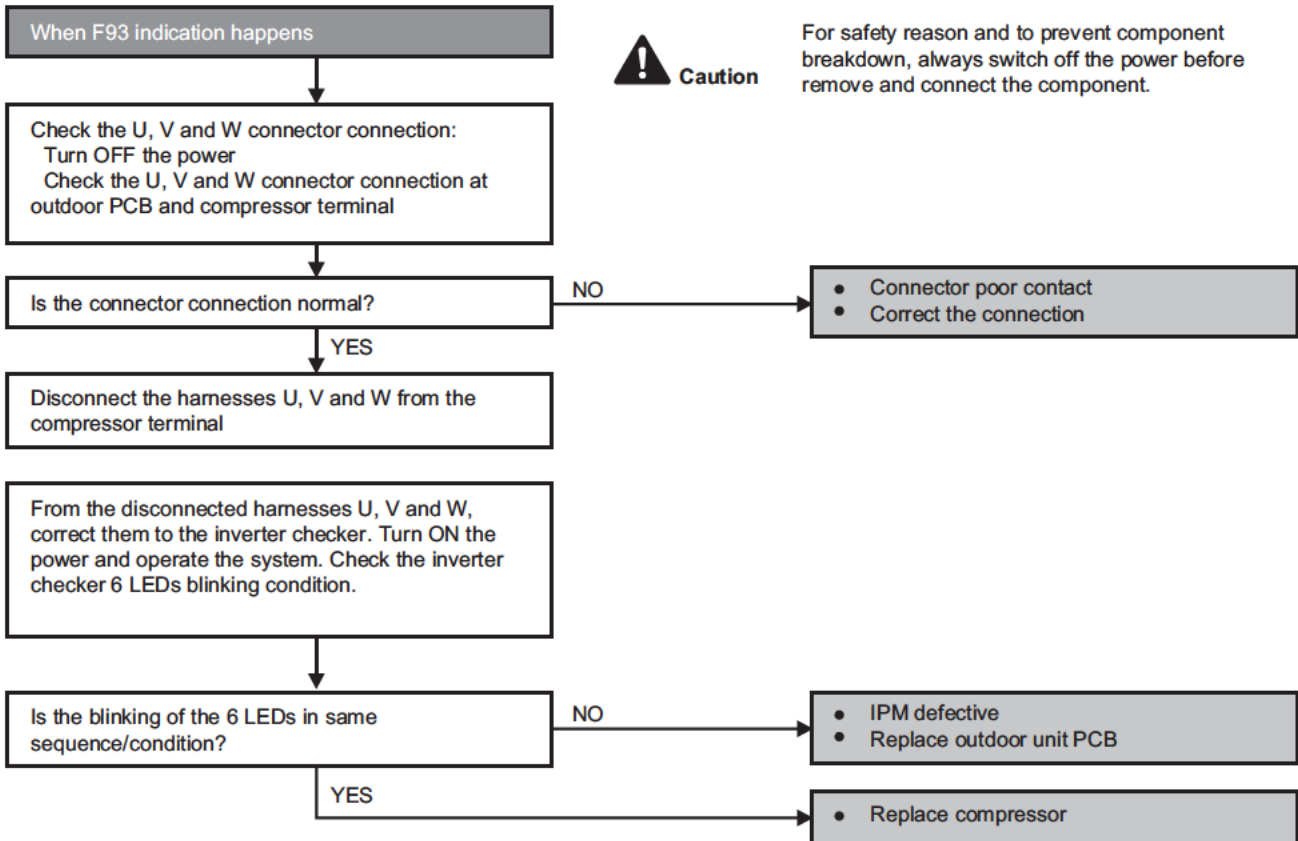

14.5.20 F95 (Outdoor High Pressure Protection: Cooling or Soft Dry)

Malfunction Decision Conditions

- During operation of cooling or soft dry, when outdoor unit heat exchanger high temperature data is detected by the outdoor unit heat exchanger thermistor.

Malfunction Caused

- Outdoor heat exchanger temperature rise due to short-circuit of hot discharge air flow.
- Outdoor heat exchanger temperature rise due to defective of outdoor fan motor.
- Outdoor heat exchange temperature rise due to defective outdoor heat exchanger thermistor.
- Outdoor heat exchanger temperature rise due to defective of outdoor unit PCB.

Troubleshooting

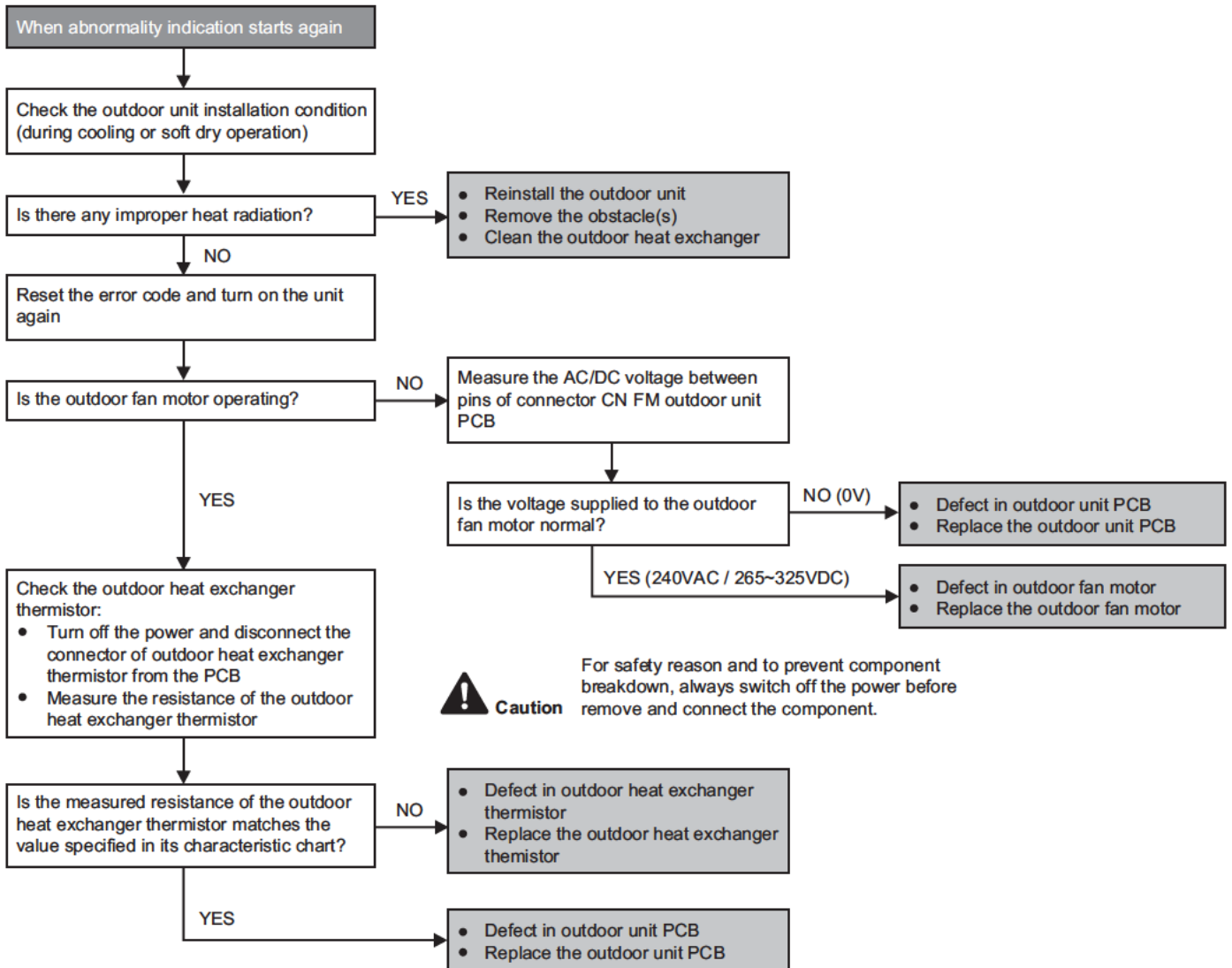

14.5.21 F96 (IPM Overheating)

Malfunction Decision Conditions

- During operating of cooling and heating, when IPM temperature data (212°F) is detected by the IPM temperature sensor.

Multi Models only

- Compressor Overheating: During operation of cooling and heating, when the compressor OL is activated.
- Heat Sink Overheating: During operation of cooling and heating, when heat sink temperature data (194°F) is detected by the heat sink temperature sensor.

Malfunction Caused

- IPM overheats due to short circuit of hot discharge air flow.
- IPM overheats due to defective of outdoor fan motor.
- IPM overheats due to defective of internal circuitry of IPM.
- IPM overheats due to defective IPM temperature sensor.

Multi Models Only

- Compressor OL connector poor contact.
- Compressor OL faulty.

Troubleshooting

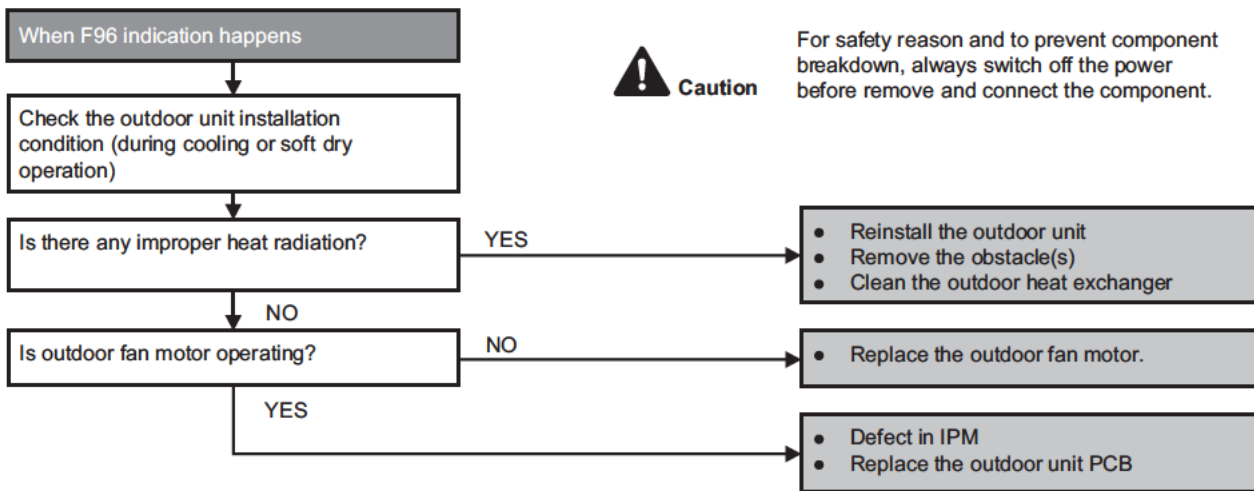

14.5.22 F97 (Compressor Overheating)

Malfunction Decision Conditions

- During operation of cooling and heating, when compressor tank temperature data (233.6°F) is detected by the compressor tank temperature sensor.

Malfunction Caused

- Faulty compressor tank temperature sensor
- 2/3 way valve closed
- Refrigerant shortage (refrigerant leakage)
- Faulty outdoor unit PCB
- Faulty compressor

Troubleshooting

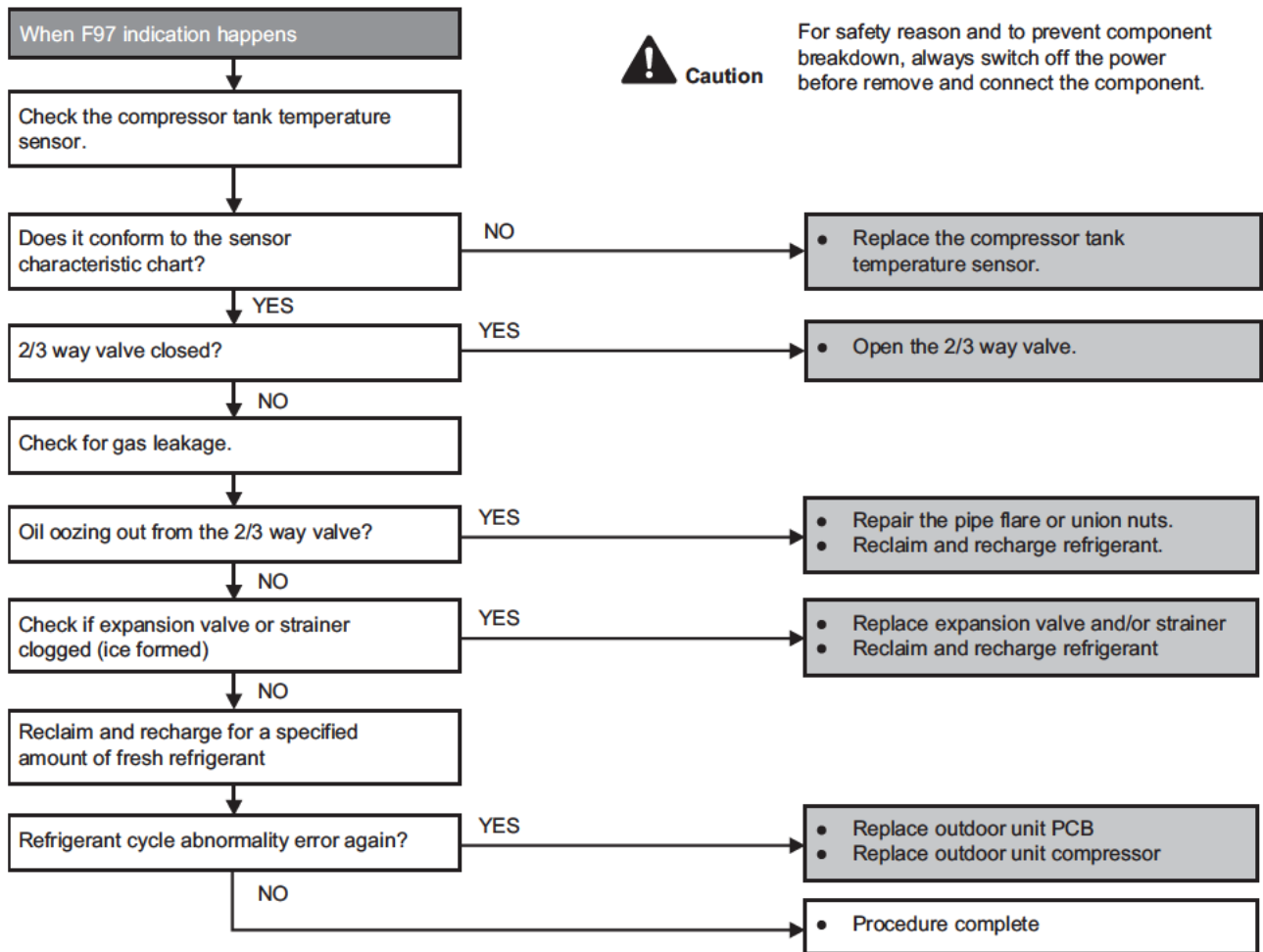

14.5.23 F98 (Input Over Current Detection)

Malfunction Decision Conditions

- During operation of cooling and heating, when an input over-current (X value in Total Running Current Control) is detected by checking the input current value being detected by current transformer (CT) with the compressor running.

Malfunction Caused

- Excessive refrigerant.
- Faulty outdoor unit PCB.

Troubleshooting

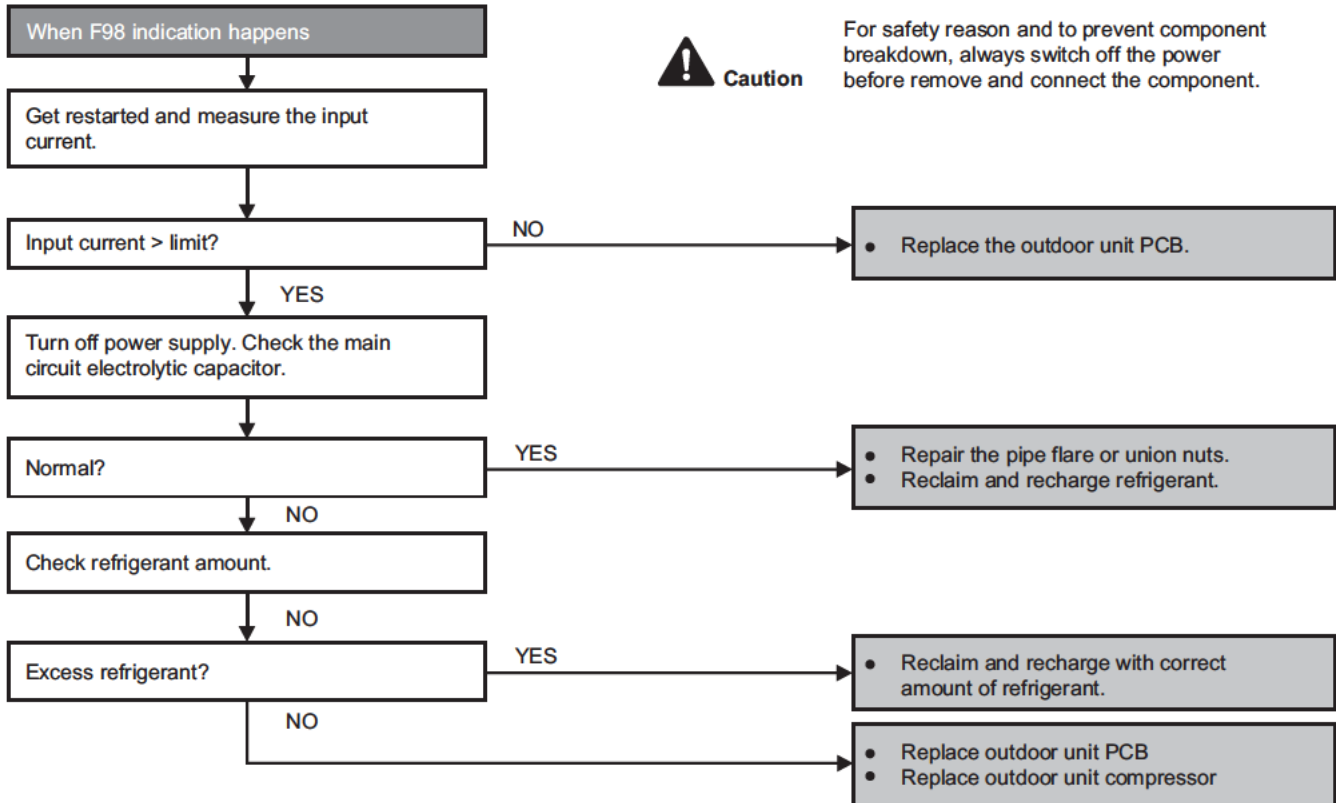

14.5.24 F99 (DC Peak Detection)

Malfunction Decision Conditions

During startup and operation of cooling and heating, when inverter DC peak data is received by the outdoor internal DC Peak sensing circuitry.

Malfunction Caused

- DC current peak due to compressor failure.
- DC current peak due to defective power transistor(s).
- DC current peak due to defective outdoor unit PCB.
- DC current peak due to short circuit.

Troubleshooting

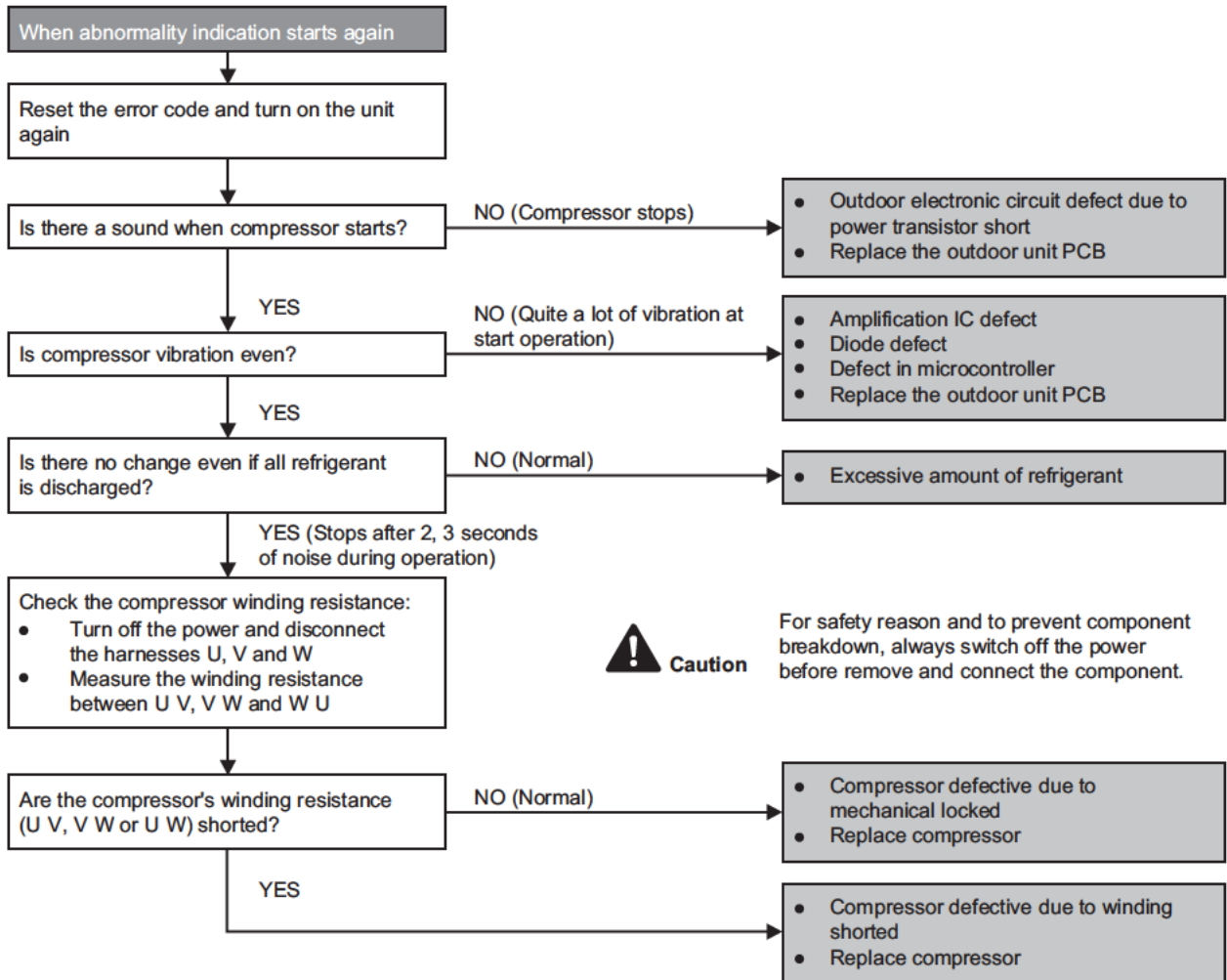

15. Disassembly and Assembly Instructions

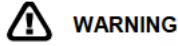

High Voltage are generated in the electrical parts area by the capacitor. Ensure that the capacitor has discharged sufficiently before proceeding with repair work. Failure to heed this caution may result in electric shocks.

15.1 Indoor Electronic Controller, Blower Fan, Fan Motor & Drain Motor Removal Procedure.

15.1.1 To Remove Cabinet Bottom Plate

- 1 Unscrew 14 screws on the cabinet bottom plate, 10 screws on the cabinet top plate and detach cabinet bottom plate and cabinet top plate from unit.

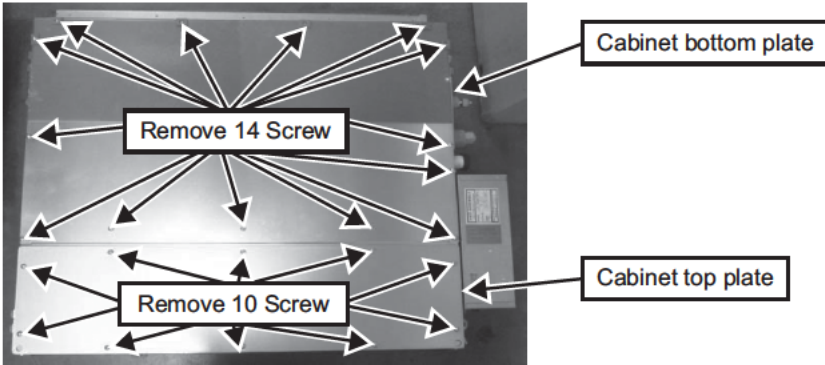

15.1.2 To Remove Electronic Controller

- 1 Unscrew the 2 screws on the Control Board and open the Control Board Cover.

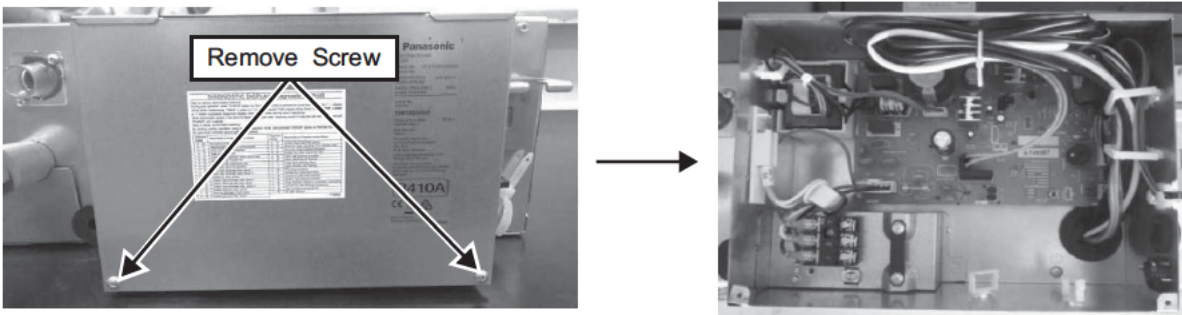

- 2 Detach all connectors as labeled from the electronic controller. Then pull out main controller gently.

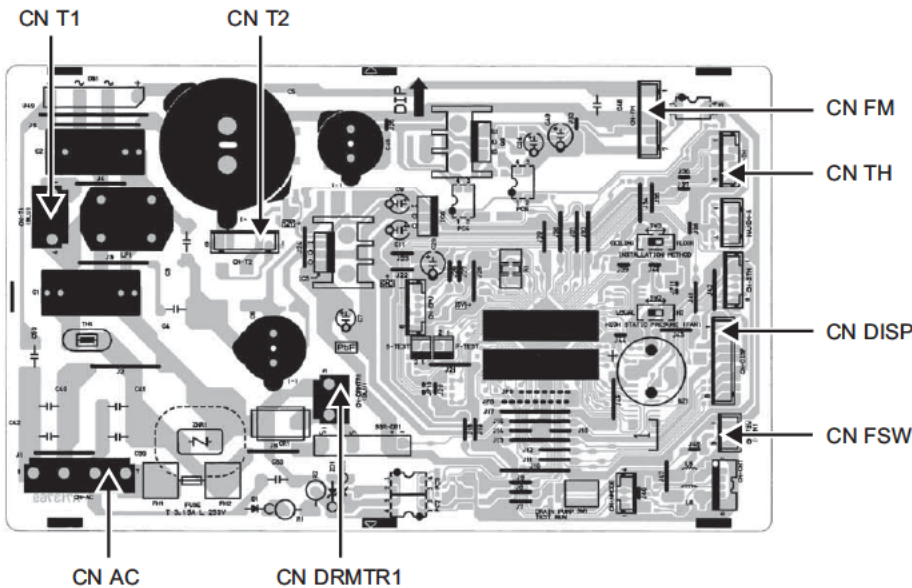

15.1.3 To Remove Fan Motor and Blower Fan

- 1 Detach the Upper and Inner Casing
- 2 Disengage the 4 catches (2 each on the left and right) on the Air Guide.

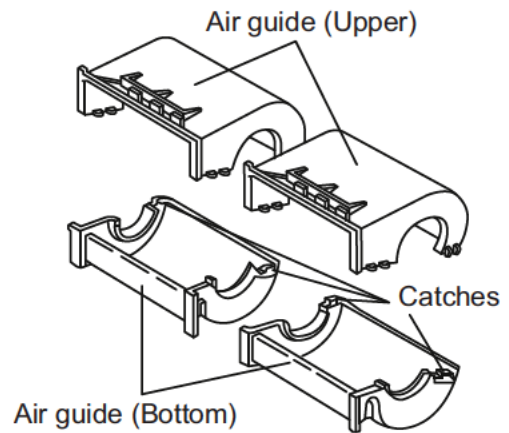
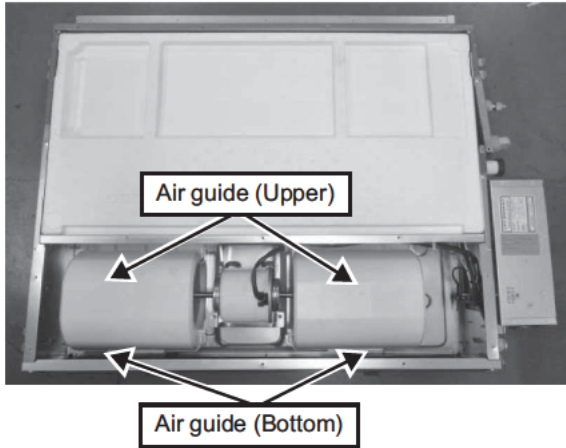

- 3 Unscrew the 2 screws on the Fan Motor Bracket and detach Fan Motor Bracket.
- 4 Remove the Fan Motor and Blower Fan from the unit.
- 5 Use a 3.0 mm hexagonal wrench to loosen the bolts connecting the Fan Motor and Fan. Detach the shaft connecting the Fan Motor and Blower Fan.

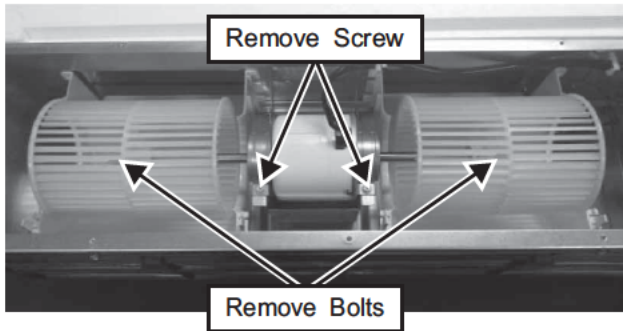

15.1.4 To Remove the Drain Motor

- 1 Unscrew the 1 screw on the Side Plate and remove Drain Pan from the unit.

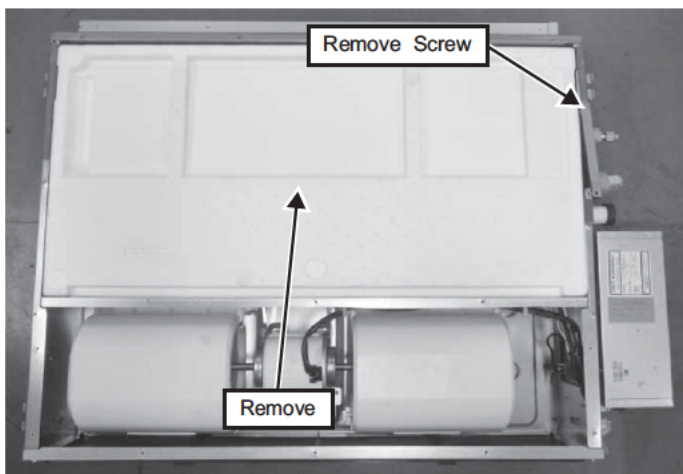

2 Unscrew 5 screws on the Evaporator and remove 2 sensor from holder and remove Evaporator from the unit.

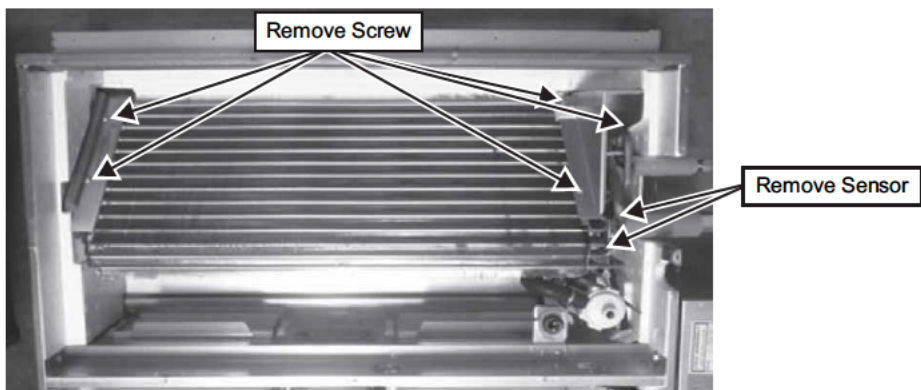

3 Unscrew 4 screws, 1 nut and 1 Spring Clip on the Drain Motor Bracket and remove Drain Motor from unit.

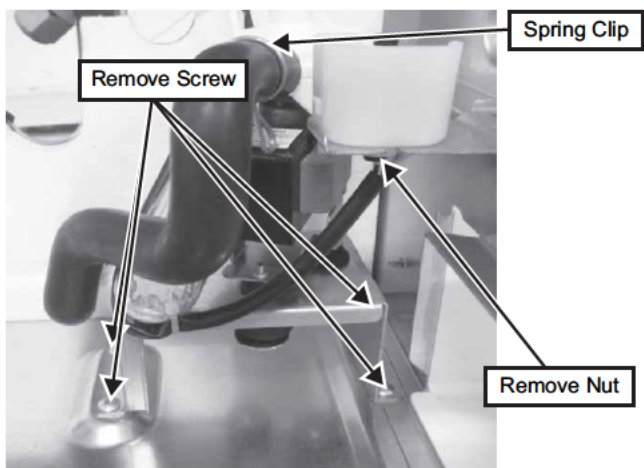

4 Unscrew 3 screws on the Drain Motor and detach the Drain Motor from Drain Motor Bracket.

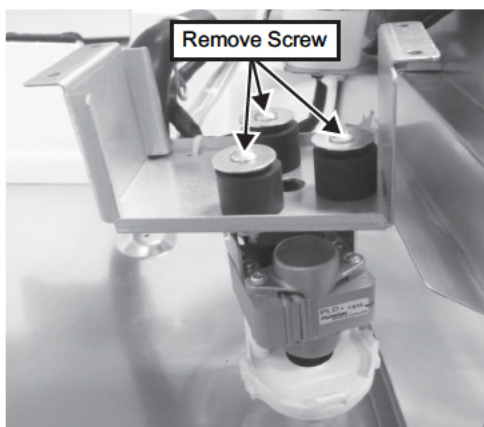

16. Technical Data

16.1 Fan Performance

16.1.1 CS-ME5SD3UA

Test Report

RPM	Static Pressure (Pa)	Airflow (m ³ /min)
1440	-0.1	17.7
	7.7	17.1
	28.4	15.5
	44.9	13.9
	59.0	12.5
	70.3	11.2
1200	-0.1	15.4
	9.1	14.5
	23.5	13.0
	36.5	11.5
	42.8	10.6
1080	0.0	12.7
	9.1	11.6
	19.1	10.4
	26.3	9.4

RPM	Static Pressure (Pa)	Airflow (m ³ /min)
1040	0.0	12.0
	9.1	10.9
	19.1	9.6
	26.3	8.5
	0.0	9.8
940	8.8	8.8
	19.3	7.2
	26.1	5.9
880	0.0	8.8
	9.1	7.8
	19.1	6.1
	26.3	4.6

Fan Performance Curve

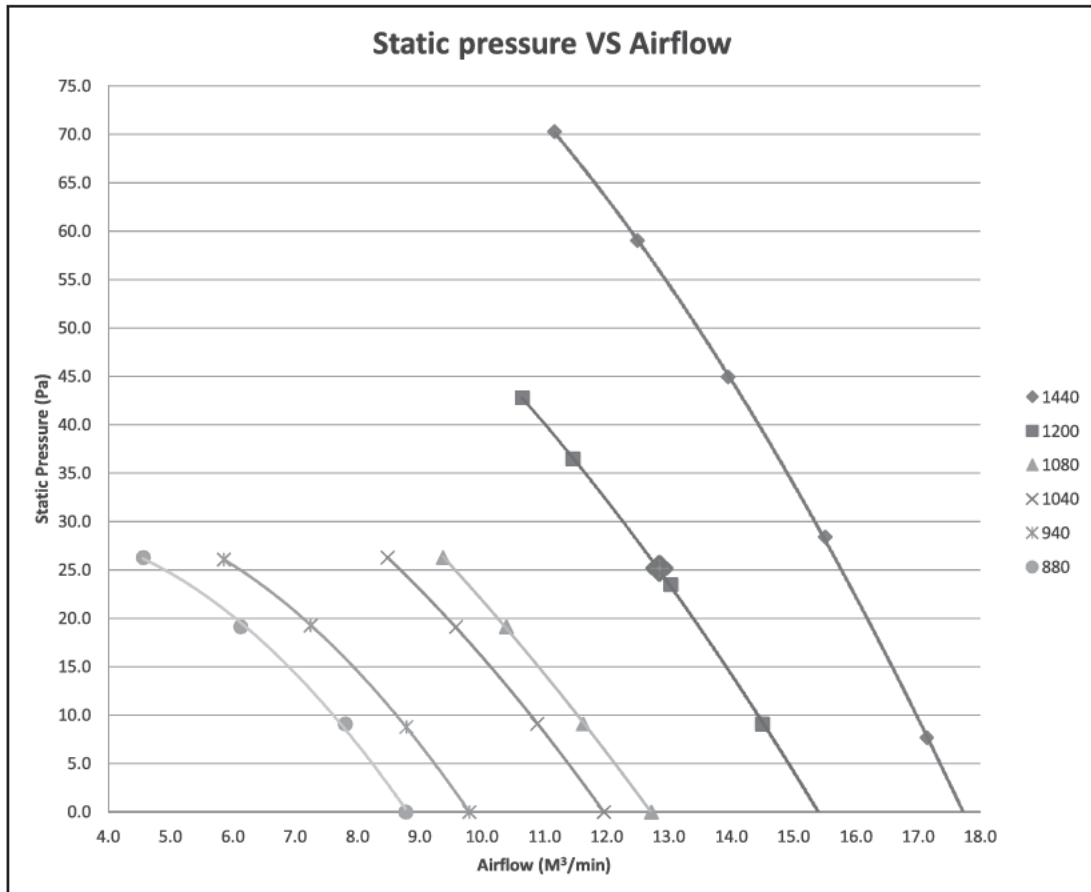

Cool	RPM	Static Pressure	Airflow (m ³ /min)
Hi Fan (Standard)	1200	25 Pa	12.9
SHi Fan (Hi Static P selected)	1440	56 Pa	12.9
Me Fan (Standard)	1080	20 Pa	10.3
Lo Fan (Standard)	940	15 Pa	7.7

Heat	RPM	Static Pressure	Airflow (m ³ /min)
Hi Fan (Standard)	1200	25 Pa	12.9
SHi Fan (Hi Static P selected)	1440	56 Pa	12.9
Me Fan (Standard)	1040	18.5 Pa	9.8
Lo Fan (Standard)	880	13 Pa	7.2

16.1.2 CS-ME7SD3UA

Test Report

RPM	Static Pressure (Pa)	Airflow (m ³ /min)
1470	0.1	18.0
	7.7	17.4
	28.5	15.8
	45.2	14.3
	59.2	12.9
	70.0	11.6
1230	-0.1	15.6
	9.1	14.7
	23.5	13.3
	36.5	11.8
	42.8	11.1
1090	0.0	13.0
	9.1	11.9
	19.1	10.7
	26.3	9.7

RPM	Static Pressure (Pa)	Airflow (m ³ /min)
1060	0.0	12.5
	9.1	11.4
	19.1	10.2
	26.3	9.1
	0.0	9.8
940	8.8	8.8
	19.3	7.2
	26.1	5.9
880	0.0	8.9
	9.1	7.9
	19.1	6.2
	26.3	4.7

Fan Performance Curve

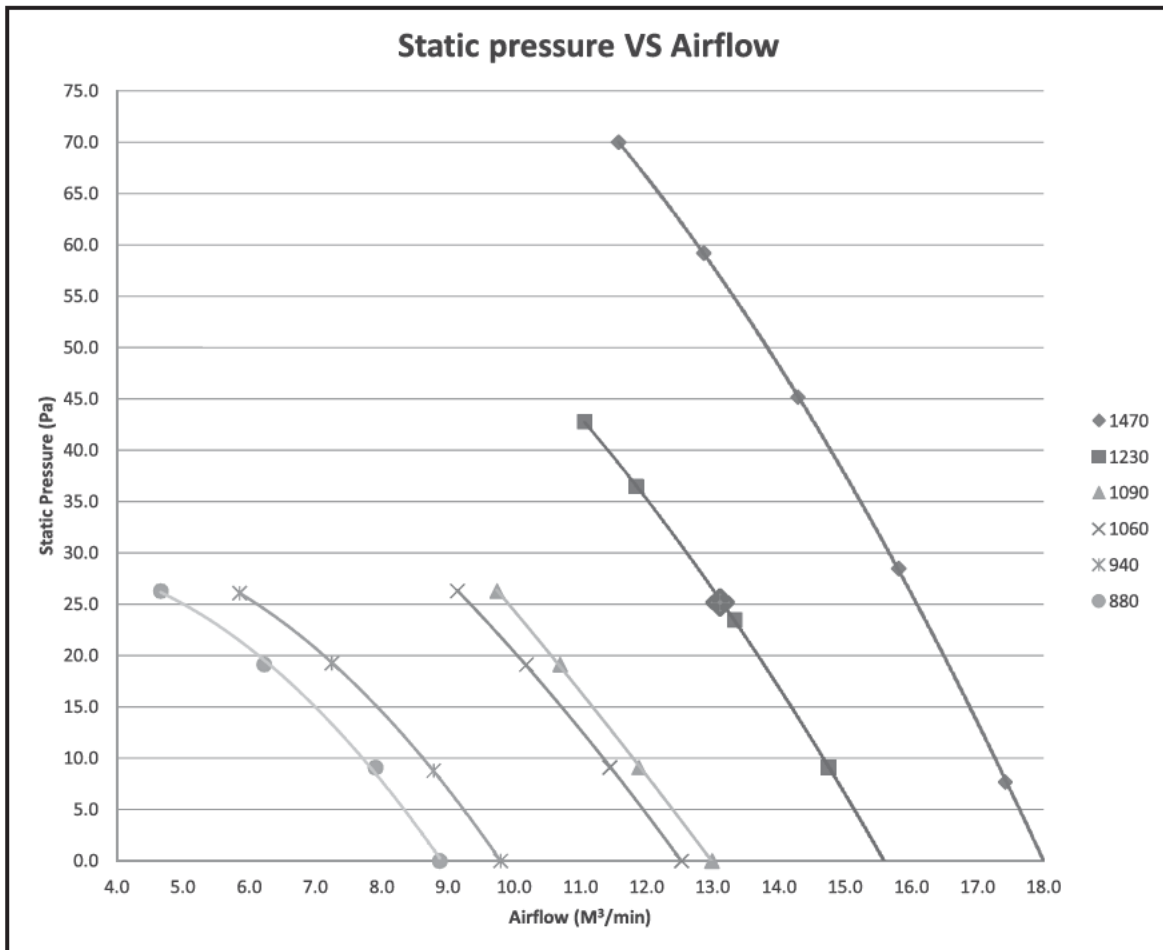

Cool	RPM	Static Pressure	Airflow (m ³ /min)
Hi Fan (Standard)	1230	25 Pa	13.2
Hi Fan (Hi Static P selected)	1470	56 Pa	13.2
Me Fan (Standard)	1090	20 Pa	10.6
Lo Fan (Standard)	940	15 Pa	7.9

Heat	RPM	Static Pressure	Airflow (m ³ /min)
Hi Fan (Standard)	1230	25 Pa	13.2
Hi Fan (Hi Static P selected)	1470	56 Pa	13.2
Me Fan (Standard)	1060	19 Pa	10.3
Lo Fan (Standard)	880	13 Pa	7.3

17. Exploded View and Replacement Parts List

17.1 Indoor Unit

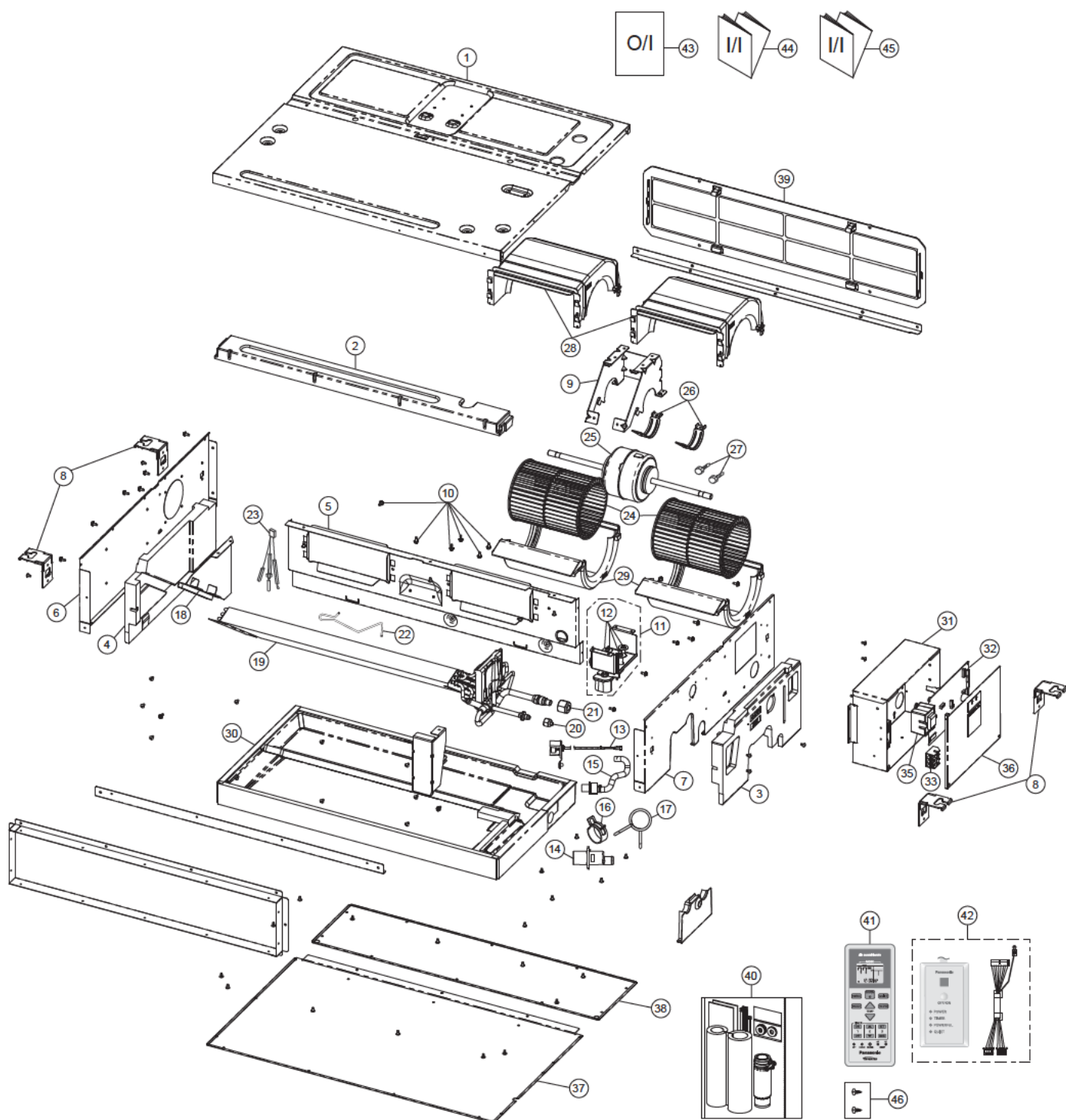

Note:
The above exploded view is for the purpose of parts disassembly and replacement.
The non-numbered parts are not kept as standard service parts.

SAFETY	REF. NO.	PART NAME & DESCRIPTION	QTY.	CS-ME5SD3UA	CS-ME7SD3UA	REMARK
	1	CABINET TOP PLATE - COMPLETE	1	CWE03C1169	←	
	2	FOAMED STYRENE COMPLETE	1	ACXG07C00070	←	
	3	FOAMED STYRENE COMPLETE	1	CWG07C1092	←	
	4	FOAMED STYRENE COMPLETE	1	CWG07C1093	←	
	5	BULKHEAD	1	CWD531059	←	
	6	CABINET SIDE PLATE - COMPLETE	1	CWE04C1565	←	
	7	CABINET SIDE PLATE - COMPLETE	1	CWE04C1566	←	
	8	PARTICULAR PLATE	4	CWD912571	←	
	9	FAN MOTOR BRACKET	1	CWD541246	←	
	10	SCREW - FAN MOTOR BRACKET	7	CWH55406J	←	
	11	PUMP - COMPLETE	1	ACXB53C00020	←	O
	12	ANTI-VIBRATION BUSHING	3	CWH501131	←	
	13	FLOAT SWITCH COMPLETE	1	CWA12C1034	←	O
	14	DRAIN NOZZLE	1	CWH411027	←	
	15	FLEXIBLE PIPE - COMPLETE	1	CWH85C1120	←	
	16	PLATE SPRING	1	CWH711022	←	
	17	WIRE SPRING	1	CWH722018	←	
	18	PARTICULAR PIECE - COMPLETE	1	CWD93C1191	←	
	19	FIN & TUBE EVAPORATER - COMPLETE	1	ACXB30C01510	←	
	20	FLARE NUT (1/4)	1	CWT251030	←	
	21	FLARE NUT (1/2)	1	CWT251031	←	
	22	HOLDER - SENSOR	2	CWH32143	←	
	23	SENSOR COMPLETE	1	ACXA50C00030	←	O
	24	BLOWER WHEEL ASS'Y	2	CWH01K1041	←	
⚠	25	FAN MOTOR	1	L6CBYYYYL0179	←	O
	26	FAN MOTOR BRACKET	2	CWD541265	←	
	27	SCREW - FAN MOTOR BRACKET	1	CWH551049J	←	
	28	AIR GUIDER B.W.	2	CWD321112	←	
	29	AIR GUIDER B.W.	2	CWD321113	←	
	30	DRAIN PAN - COMPLETE	1	CWH40C1134	←	
	31	CONTROL BOARD A'SSY	1	ACXH10K00130	←	
⚠	32	ELECTRONIC CONTROLLER - (MAIN)	1	ACXA73C06960	ACXA73C06970	O
⚠	33	TERMINAL BOARD ASS'Y	1	CWA28K1161	←	O
⚠	35	TRANSFORMER - COMPLETE	1	CWA40C1106	←	O
	36	CONTROL BOARD COVER	1	ACXH13C00080	←	
	37	CABINET BOTTOM PLATE - COMPLETE	1	CWE05C1014	←	
	38	CABINET TOP PLATE	1	CWE031215	←	
	39	AIR FILTER	1	CWD001390	←	
	40	ACCESSORY - COMPLETE	1	CWH82C2111	←	
	41	REMOTE CONTROL COMPLETE	1	ACXA75C01440	←	O
	42	ACCESSORY - COMPLETE (RECEIVER)	1	ACXH82C00420	←	O
	43	OPERATING INSTRUCTION	1	ACXF55-01620	←	
	44	INSTALLATION INSTRUCTION	1	ACXF60-02670	←	
	45	INSTALLATION INSTRUCTION	1	ACXF60-02680	←	
	46	ACCESSORY - COMPLETE	1	CWH82C234	←	

(Note)

- All parts are supplied from PAPAMY, Malaysia (Vendor Code: 00029488).
- "O" marked parts are recommended to be kept in stock.