

Split System Submittal Data

System: E9RKUA Indoor: CS-E9RKUAW Outdoor: CU-E9RKUA

Job Name: _____
 Location: _____
 Engineer: _____
 Submitted to: _____
 Submitted by: _____
 Reference: _____

Approval: _____
 Date: _____
 Construction: _____
 Unit #: _____
 Drawing #: _____

General Data	
Power (V/P/Hz)	230/208/1/60
Circuit Ampacity (A)	15
Fuse Size, Max.(A)	15
Compressor	DC Twin Rotary (Inverter)
No. Used	1
Motor Type (No. of poles)	DC Brushless (4 poles)
Output Power (W)	700
Outdoor Unit	
Fan Type	Propeller
No. Speeds	Variable speed
Type Drive	Direct / DC Motor
No. Poles (RPM)	8-830
No. Motors (W)	1-40
CFM (Hi speed)	1095
Coil Type	Aluminum Fin and Copper Pipe
Fin Type - Pipe Type	Coated Corrugated fin – Inner Rifled
Rows x stage x F.P.I.	2 x 24 x 17
Size (W x H x L)	1-13/32 x 19-13/16 x 28-1/16
Tube Size (in.)	9/32
Indoor Unit	
Fan Type	Cross Flow
Motor Type, No. of Poles	DC Brushless 8 poles
No. Speeds	Variable speed
RPM (Cool / Heat), High	1210 / 1340
No. Motors (W)	1-47
CFM (Ql/Lo/Me/Hi/SHi) Cooling	222/261/340/425/459
CFM (Ql/Lo/Me/Hi/SHi) Heating	250/290/373/455/491
Operating Sound-H/L/QLo/ dB-A (Cool)	40/25/20
Operating Sound-H/L/QLo/ dB-A (Heat)	42/29/26
Coil Type	Aluminum Plate Fin & Copper Tube
Fin Type - Pipe Type	Coated Slit Plate - Inner Rifled
Row x stage x FPI	2 x 15 x 21
Dimension	1 x 12-13/32 x 24
Tube Size (in.)	9/32"
Drain Connection Size (in.)	3/4"
Refrigerant	R410A
OZ. - R410a (outdoor unit)	34.6
Refrigerant Control	Electronic Expansion Valve
Refrigerant Tubing Connections	Flare



Longueur max. du conduit (pi)	65.6
Elevation Difference, Max (ft.)	49.2
Line Size (in. O.D. Discharge)	1/4"
Line Size (in. O.D. Suction)	3/8"
Pre-charge, tubing length at shipment	24.6'
Dimensions (HxWxD)	
Indoor Unit (Crated) (in.)	14-3/16 x 37-13/16 x 9-29/32
Indoor Unit (Uncrated) (in.)	11-7/16 x 34-9/32 x 8-7/16
Outdoor Unit (Crated) (in.)	23-15/32 x 36-9/32 x 16-13/32
Outdoor Unit (Uncrated) (in.)	21-9/32 x 30-23/32 x 11-13/32
Weight (lbs.)	
(Indoor) Net	20lb
(Indoor) Shipping	22lb
(Outdoor) Net	82lb
(Outdoor) Shipping	90lb

Performance Data @ ARI Standard Conditions	
Cooling	
Total Capacity (BTU/H)	9000 (41,00-10,200)
Sensible Capacity (BTU/H)	8560
Latent Capacity (BTU/H)	440
SEER	23.0
Dehumidification (Pints/H)	1.3
Amps (A)	3.2
Power Input (W)	690
Outdoor Sound Rating (dB-A)	47
Heating	
Total Capacity (BTU/H)	12,000 (4,100-14,100)
HSPF	11.0
Amps (A)	5.1
Power Input (W)	1120
Outdoor Sounds Rating (dB-A)	48

Features	
Controls	Microprocessor
Remote Controller	LCD Wireless Type included as standard
Wired Remote Controller	Optional CZ-RD516C-1
Temperature Control	IC Thermistor
Timer	Single Event Daily ON/OFF TIMER
Quiet mode	Included
High Power mode	Included
Air Louver, Horizontal	Manual
Air Louver, Vertical	Automatic, Sweep, Step
Power Failure Automatic Restart	Built-In
Heating/Cooling Automatic Changeover	Built-In
Self-Diagnosis	Built-In
Air Filter	Washable, One-touch

Operating Range	Indoor Air Intake Temp	Outdoor Air Intake Temp
Cooling (Max)	89.6F DB/73.4F WB	114.8F DB
Cooling (Min)	60.8F DB/51.8F WB	0F DB
Heating (Max)	86.0F DB	75.2F DB/64.4F WB
Heating (Min)	60.8DB	-4.0F DB/-5.8F WB



Indoor Dimensions

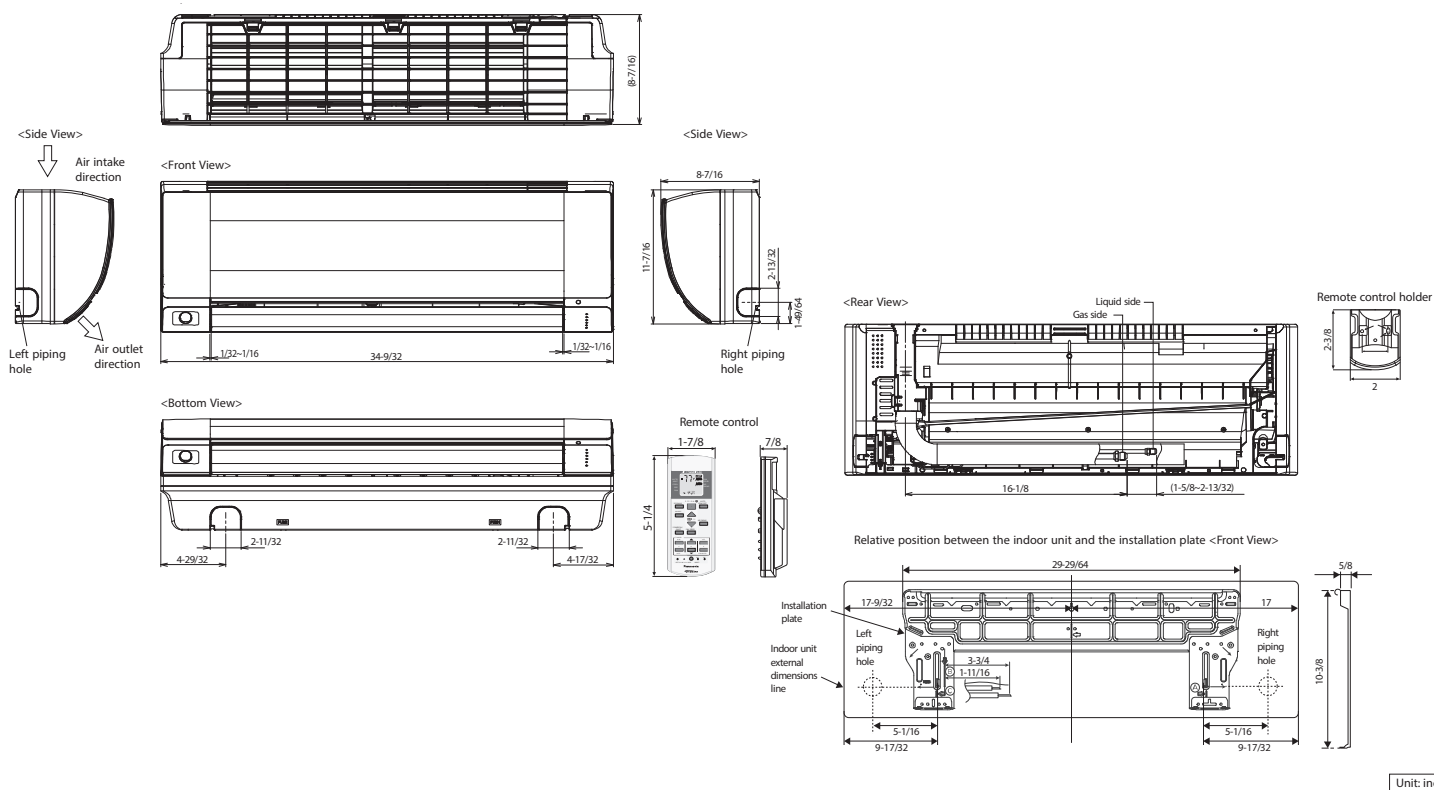

Outdoor Dimensions

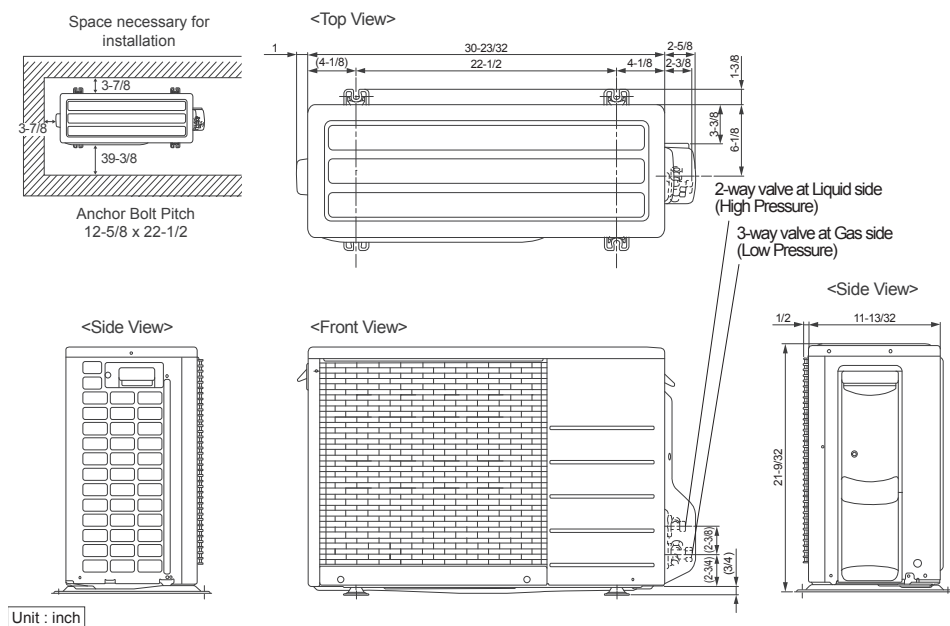

Panasonic Canada Inc
 Home and Building Solutions
 5770 Ambler Drive
 Mississauga, ON L4W 2T3