

# Panasonic

**This Through-the-Wall Ventilation Fan requires no duct work when installed on an outside wall. It's easy to install and super quiet. The advanced motor design ensures long life and is energy efficient.**

- Remarkable performance and super quiet operation at .25" w.g.
- ENERGY STAR® qualified
- Fully enclosed condenser motor for long life —rated for 30,000-hours continuous run
- Easy installation
- Rustproof paint treatment on galvanized housing
- Built-in spring damper and foam seal to prevent back-draft
- Contemporary grille design
- cUL listed for tub/shower enclosure when used with a GFCI branch circuit wire
- Thermal fuse protection
- ASHRAE 62.2, LEED for Homes and ENERGY STAR® compliant
- 10" galvanized sleeve and durable steel exterior hood included
- Through-the-wall sleeve accommodates walls up to 10" (254mm) thick
- Bird screen
- 3-year warranty

**WhisperWall™**  
VENTILATION FAN

# WhisperWall Ventilation Fans

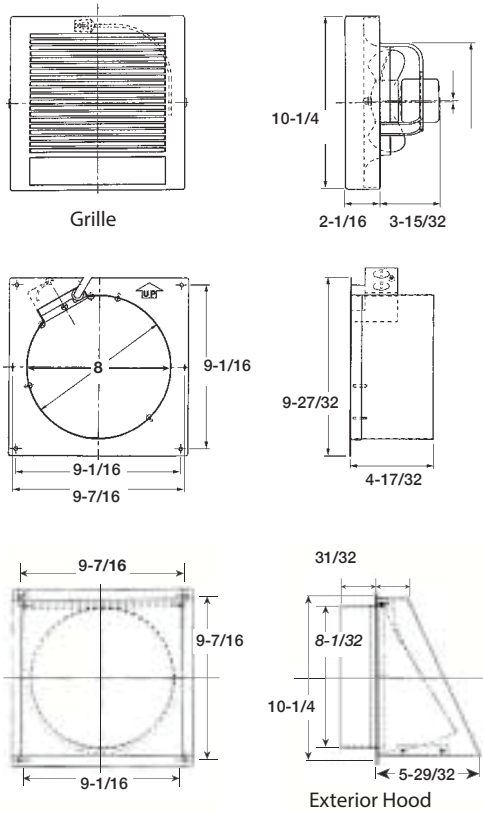

FV-08WQ1 70 CFM



Exterior Hood included

	WhisperWall	FV-08WQ1
Ventilation Fan Characteristics	Static Pressure in inches w.g.	0.03
	Air Volume (CFM)	70
	Noise (sones)	1.1
	Power Consumption (Watts)	18
	Energy Efficiency (CFMs/Watt)	3.9
	Speed (RPM)	660
	Current (amps)	0.20
	Power Rating (V, Hz)	120/60
Specifications	Motor Type	Condenser
	Type of Motor Bearing	Sleeve
	Thermal Fuse Protection	Yes
	Blower Wheel Type	Propeller
	ENERGY STAR® Qualified	Yes
Installation	Duct Diameter (mm/in)	203 / 8 <sup>(1)</sup>
	Opening Dimension - Square (mm/in)	216 / 8-1/2
	Grille Size - Square (mm/in)	260 / 10-1/4
	Sleeve Extension (mm/in)	up to 254 / up to 10
Shipping	Gross Weight (kg/lbs)	5.5 / 12.1
Approved Code/Standard Regulation	cUL Tub/Shower Enclosure	Yes
	HVI	Yes
	Mfg in ISO 9001 Certified Facility	Yes

w.g.=water gauge  
(1) Use enclosed template.



Panasonic ventilation fans may qualify for an energy saving rebate. Rebate programs are often provided by local utility companies and are based on ENERGY STAR® guidelines. Check with your local utility company for details.

**WhisperWall™**  
VENTILATION FAN



As an Energy Star® Partner, Panasonic has determined that this product meets the Energy Star® Guidelines for energy efficiency.

**Panasonic**

Panasonic Canada Inc.

5770 Ambler Drive, Mississauga, ON L4W 2T3

Phone (800) 669-5165 Fax (905) 238-2414

Email: ventilationfans@ca.panasonic.com

www.panasonic.com



Because its products are subject to continuous improvements, Panasonic reserves the right to modify product design and specifications without notice and without incurring any obligations.