

Specification Data

Panasonic Ventilation Fan



Description

Ventilating fan shall be Low Noise ceiling mount type rated for continuous operation. Fan shall be ENERGY STAR rated and certified by the Home Ventilating Institute (HVI). Evaluated by the Underwriters Laboratories and conform to both UL and cUL standards.

Motor/Blower:

- Four-pole totally enclosed condenser motor rated for continuous operation.
- Power Rating shall be 120 volts and 60 Hz.
- Fan shall be UL listed for tub/shower enclosure when used with a GFCI branch circuit wiring.
- Motor equipped with thermal-cutoff fuse.
- Removable with permanently lubricated plug-in motor.

Housing:

- Rust proof paint, galvanized steel body.
- Detachable 4" diameter duct adapter.
- Built in backdraft damper.
- Expandable extension bracket up to 24".
- Double hanger bar system allowing for ideal positioning.

Grille:

- Attractive design using PP material.
- Attaches directly to housing with torsion springs.

Warranty:

- The factory warranty shall be a minimum of 3 years

Typical Specifications:

Ventilating fan shall be of the ceiling mount, ENERGY STAR rated type, with no less than 110 CFM and no more than 0.3 sone as certified by the Home Ventilating Institute (HVI) at 0.1 static pressure in inches water gauge. Power consumption shall be no greater than 21.1 watts and ENERGY STAR rated with efficiency rating of no less than 5.3 CFM/watt. The motor shall be totally enclosed, four pole condenser type engineered to operate continuously. Power rating shall be 120v/60Hz. Duct diameter shall be no less than 4". Fan shall be UL and cUL listed for tub/shower enclosure when used with GFCI branch circuit wiring. Fan shall be ASHRAE 62.2, LEED, EarthCraft, California Title 24, ENERGY STAR IAP and WA Ventilation Code compliant.

FV-11VQ5 (110 CFM)

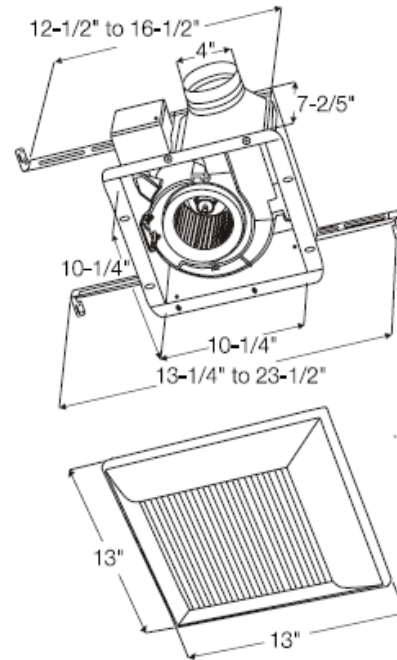

Fan Curve FV-11VQ5

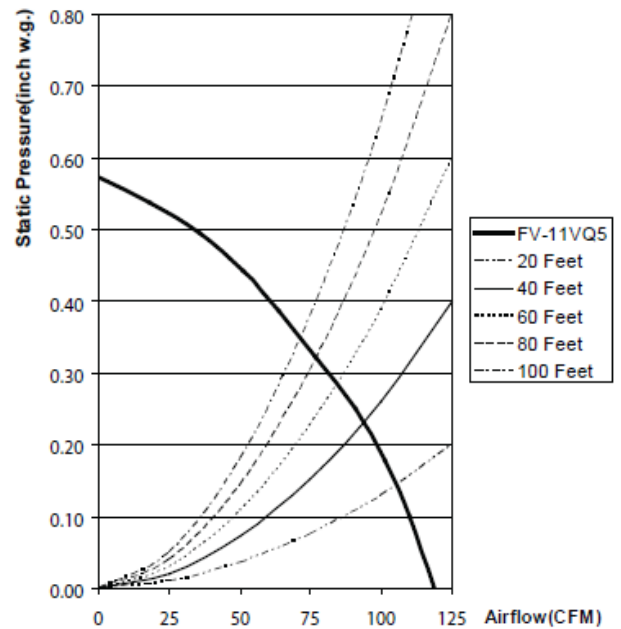

FV-11VQ5		4" Duct (Standard)	
Ventilation Fan Characteristics (HVI Certified Data)	Static Pressure (inches w.g.)	0.1	0.25
	Air Volume (CFM)	110	91
	Noise (sones)	<0.3	0.5
	Power Consumption (Watts)	21.1	20.7
	Energy Efficiency (CFM/Watts)	5.3	4.5
	Speed (RPM)	950	1161
	Current (amps)	0.18	0.17
	Power Rating (V/Hz)	120/60	
	ENERGY STAR rated	Yes	

As of 06/10

For Complete Installation Instructions, Visit www.panasonic.ca



Model	Quantity	Comments	Project:
			Location:
			Architect:
			Engineer:
			Contractor:
			Submitted by:
			Date: