

**Specification Submittal Data / Panasonic Ventilation Fan**

**Description**

Ventilating fan shall be low noise ceiling mount type rated for continuous operation. Fan shall be ENERGY STAR rated and certified by the Home Ventilating Institute (HVI). Evaluated by the Underwriters Laboratories and conform to both UL and cUL standards.

**Motor/Blower:**

- Four-pole totally enclosed condenser motor rated for continuous use.
- Power rating shall be 120 volts and 60 Hz.
- Fan shall be UL and cUL listed for tub/shower enclosure when used with a GFCI branch circuit wiring.
- Motor equipped with thermal-cutoff fuse.
- Permanently lubricated plug-in motor.

**Housing:**

- Rust proof paint, galvanized steel body.
- Detachable dual 4" or 6" diameter duct adaptor.
- Built in backdraft damper.
- Expandable extension bracket up to 24".
- Double hanger bar system allowing for ideal positioning.

**Grille:**

- Attractive design using PP material.
- Attaches directly to housing with torsion springs.

**Warranty:**

- 3-Year limited warranty.

**Architectural Specifications:**

Ventilation fan shall be ceiling mount, ENERGY STAR rated, with no less than 110 CFM and no more than 0.3 sone at 0.1 static pressure in inches water gauge (w.g.) and no less than 91 CFM, and no more than 0.5 sone as certified by HVI at 0.25" w.g. Power consumption shall be no greater than 24.3 watts at 0.1" w.g. and 24.2 watts at 0.25" w.g. ENERGY STAR rated with efficiency of no less than 4.6 CFM/Watt at 0.1" w.g. and 3.9 CFM/Watt at 0.25" w.g. The motor shall be totally enclosed, four pole condenser type engineered to run continuously. Power rating shall be 120v/60Hz. Included is a detachable dual 4" or 6" diameter duct adaptor. Dual motion and humidity sensors with adjustable delay off timer that can be set from 30 seconds to 60 minutes. Humidity sensor is the rapid rise in relative humidity (RH) type with user-adjusted set points between ~30% to ~80% RH. Fan shall be UL and cUL listed for tub/shower enclosure when used with GFCI branch circuit wiring. Fan shall be ASHRAE 62.2, LEED, ENERGY STAR IAP, EarthCraft, California Title-24, WA Ventilation Code and **CALGreen compliant**.

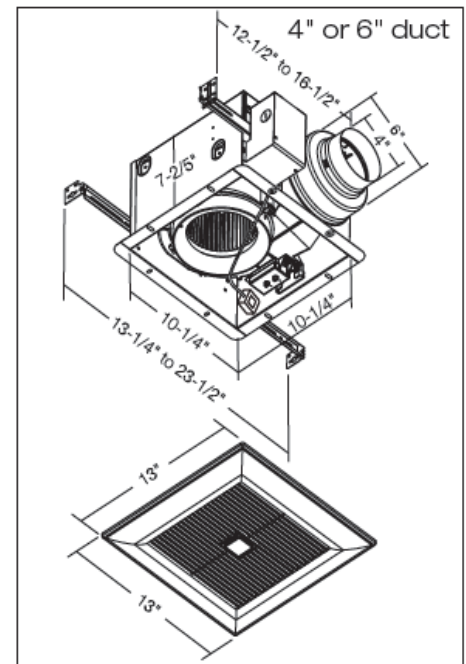

FV-11VQC5

Specifications: <b>WhisperSense FV-11VQC5</b>		<b>4" or 6" Duct (Standard)</b>	
<b>Ventilation Fan Characteristics</b> (HVI tested data)	Static Pressure in inches w.g.	0.1	0.25
	Air Volume (CFM)	110	91
	Noise (sones)	0.3	0.5
	Power Consumption (watts)	24.3	24.2
	Energy Efficiency (CFM/Watt)	4.6	3.9
	Speed (RPM)	957	1170
	Current (amps)	0.22	0.21
	Power Rating (V/Hz)	120/60	
	ENERGY STAR Qualified	YES	

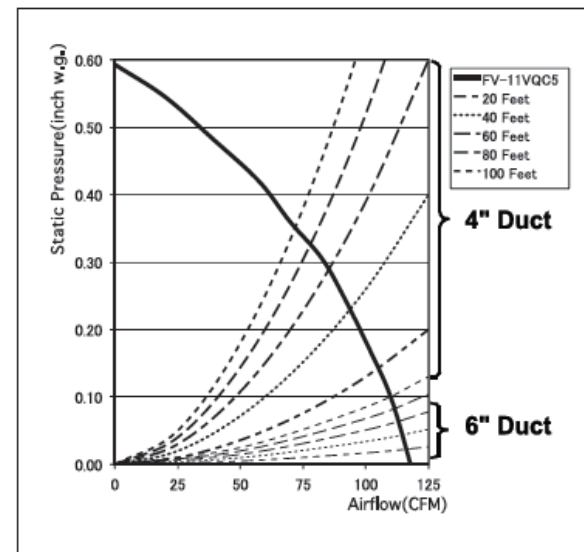

For complete Installation Instructions visit [www.panasonic.ca](http://www.panasonic.ca) under support → downloads

Model	Quantity	Comments	Project:
			Location:
			Architect:
			Engineer:
			Contractor:
			Submitted by:
			Date: