

Service Manual

Super Quiet Ventilating Fan/Light Combination

WhisperSense™
(North America Market)

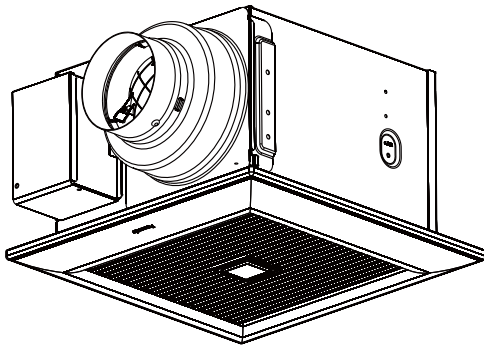

FV-08VQC5
FV-11VQC5

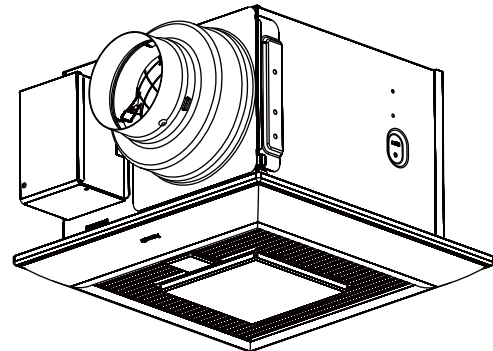

FV-08VQCL5
FV-11VQCL5



WARNING

This service information is designed for experienced repair technicians only and is not designed for use by the general public. It does not contain warnings or cautions to advise non-technical individuals of potential dangers in attempting to service a product. Products powered by electricity should be serviced or repaired only by experienced professional technicians. Any attempt to service or repair the product or products dealt with in this service information by anyone else could result in serious injury or death.

IMPORTANT SAFETY NOTICE

There are special components used in this equipment which are important for safety. These parts are marked by  in the Schematic Diagrams, Exploded Views and Replacement Parts List. It is essential that these critical parts should be replaced with manufacturer's specified parts to prevent shock, fire or other hazards. Do not modify the original design without permission of manufacture. We suggest to handle such parts after the static electricity prevention. It is forbidden to touch the PCB parts by bare hands during the repairing process.

CONTENTS	PAGE
1 Specifications	1
2 Parts Identification	2~5
3 Wiring Diagram	6
4 Parts List	7~10

Panasonic®

1. Specifications

FV-08VQC5
FV-11VQC5

Model No.	Air direction	Voltage (V)	Frequency (Hz)	Duct diameter (inches)	Noise (sones)	Power consumption (W)	Speed (rpm)	Air volume at 0.1"WG (CFM)	Weight lb.(kg)
FV-08VQC5	Exhaust	120	60	4 or 6	<0.3	15.5	815	80	10.6(4.8)
FV-11VQC5	Exhaust	120	60	4 or 6	0.3	23.0	960	110	10.6(4.8)

HVI Certified performance based on HVI Procedures 915,916,and 920.

FV-08VQCL5
FV-11VQCL5

Model No.	Air direction	Voltage (V)	Frequency (Hz)	Duct diameter (inches)	Noise (sones)	Power consumption (W)			Speed (rpm)	Air volume at 0.1"WG (CFM)	Weight lb.(kg)
						Fan	Lighting unit				
							Fluorescent lamp	Night lamp			
FV-08VQCL5	Exhaust	120	60	4 or 6	<0.3	15.5	32	4	890	80	11.7 (5.3)
FV-11VQCL5	Exhaust	120	60	4 or 6	0.7	24.5	32	4	1065	110	11.7 (5.3)

HVI Certified performance based on HVI Procedures 915,916,and 920.

2. Parts Identification

FV-08VQC5
FV-11VQC5

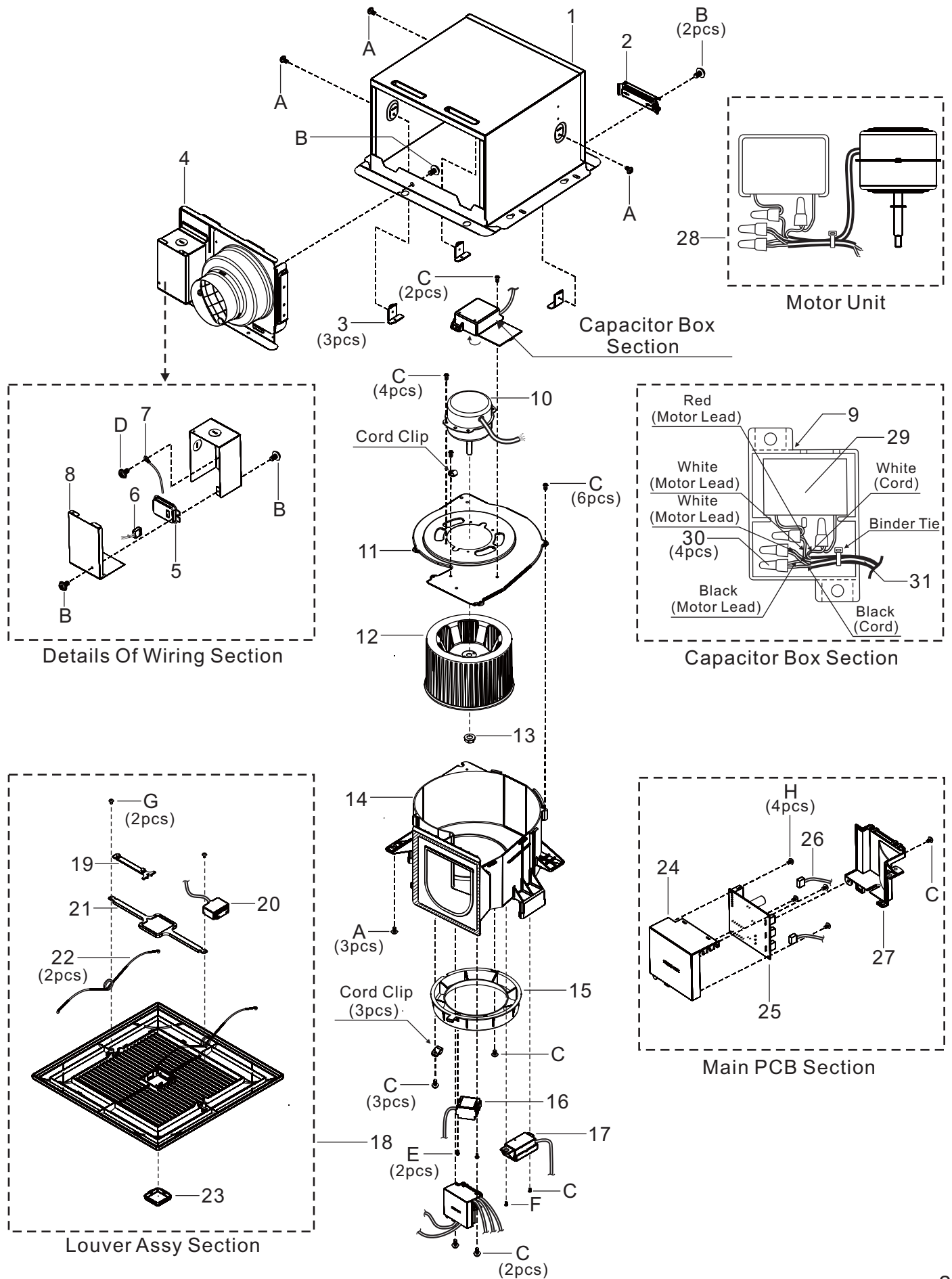

2. Parts Identification

FV-08VQC5
FV-11VQC5

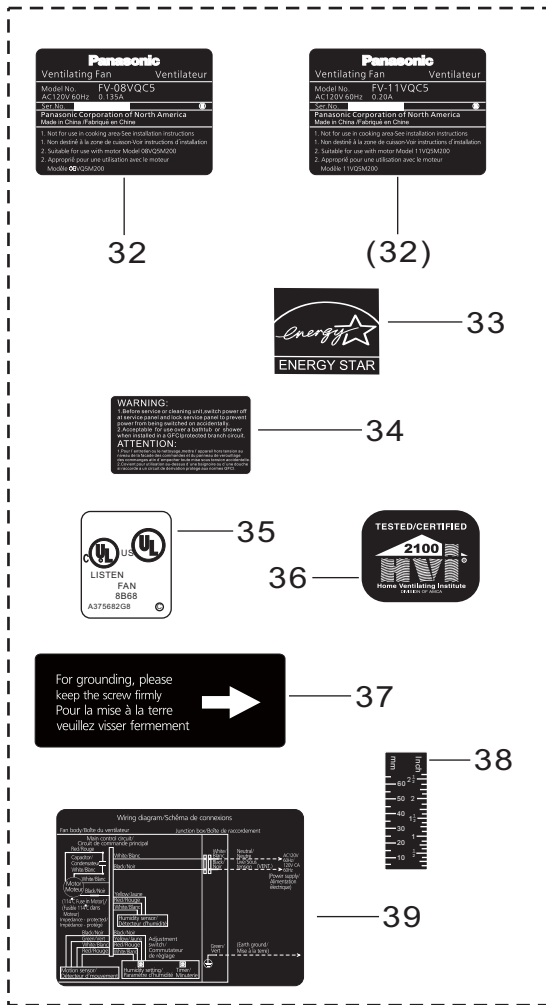

Main Labels
(Stuck On Frame Assy)

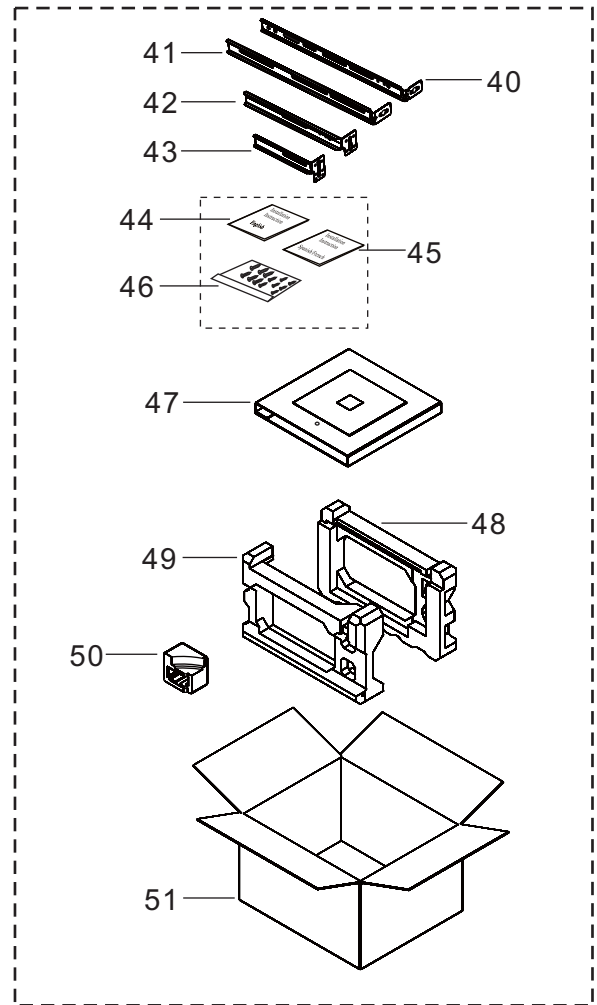

Main Packing Materials

2. Parts Identification

FV-08VQCL5
FV-11VQCL5

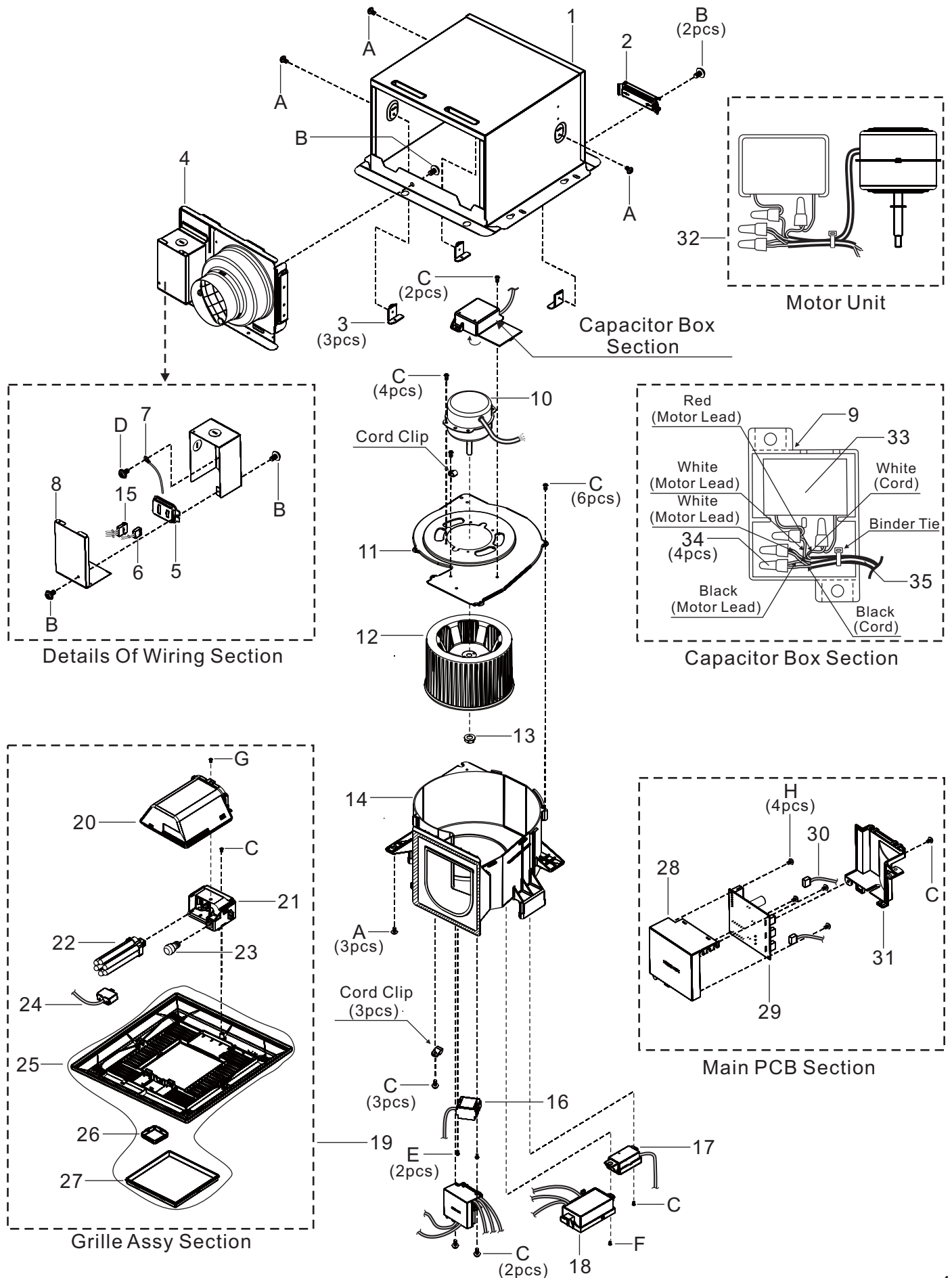

2. Parts Identification

FV-08VQCL5
FV-11VQCL5

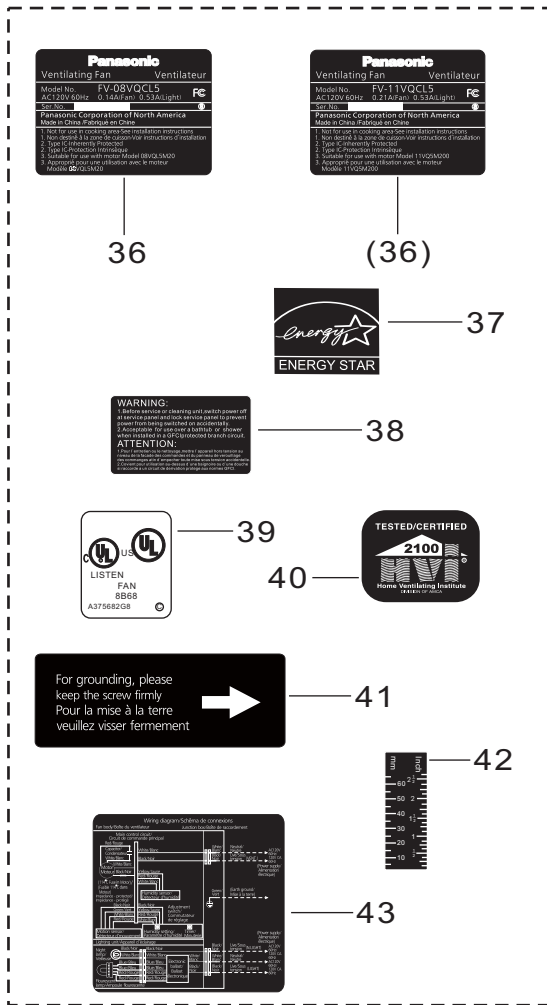

Main Labels
(Stuck On Frame Assy)

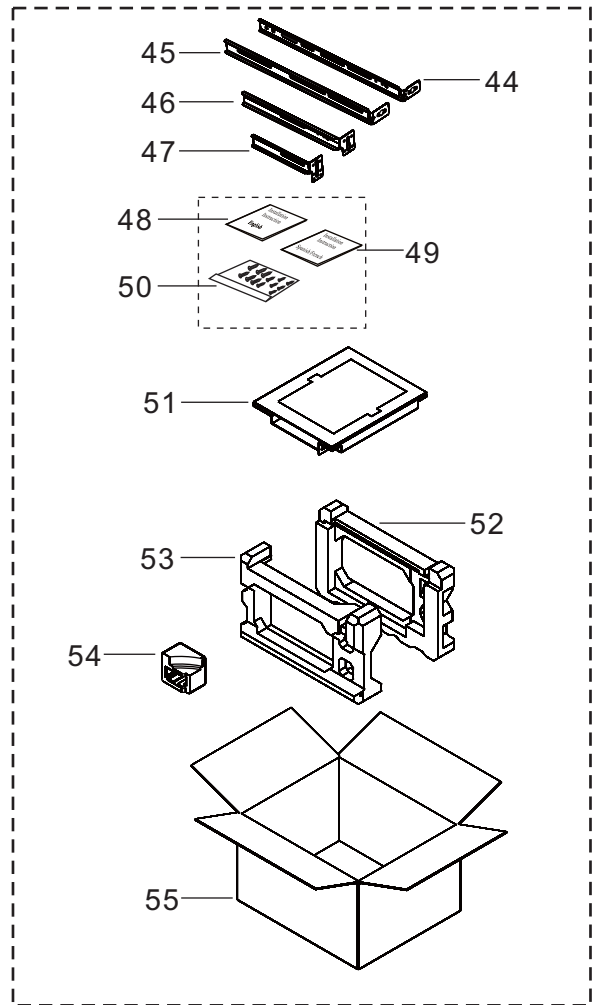

Main Packing Materials

3. Wiring Diagram

FV-08VQC5
FV-11VQC5

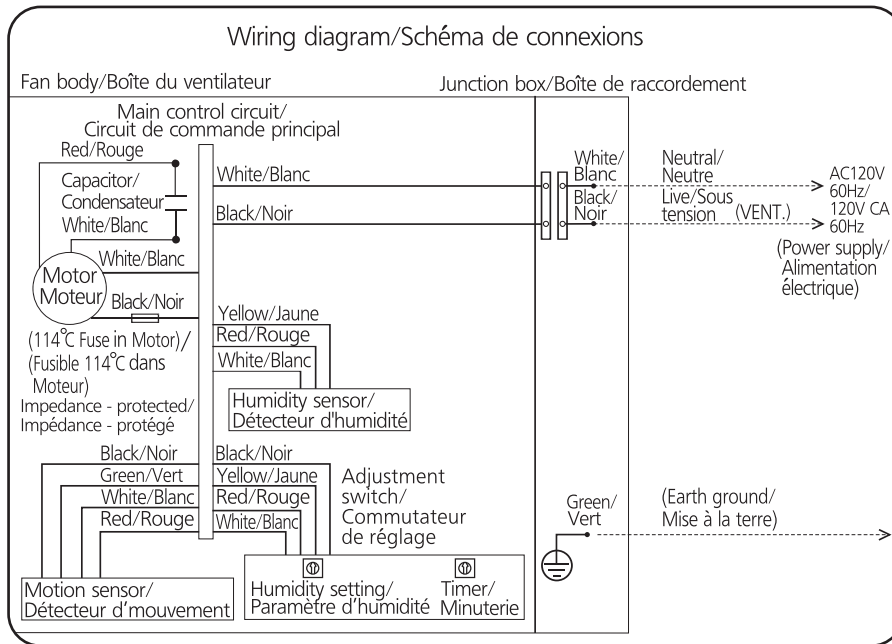

FV-08VQCL5
FV-11VQCL5

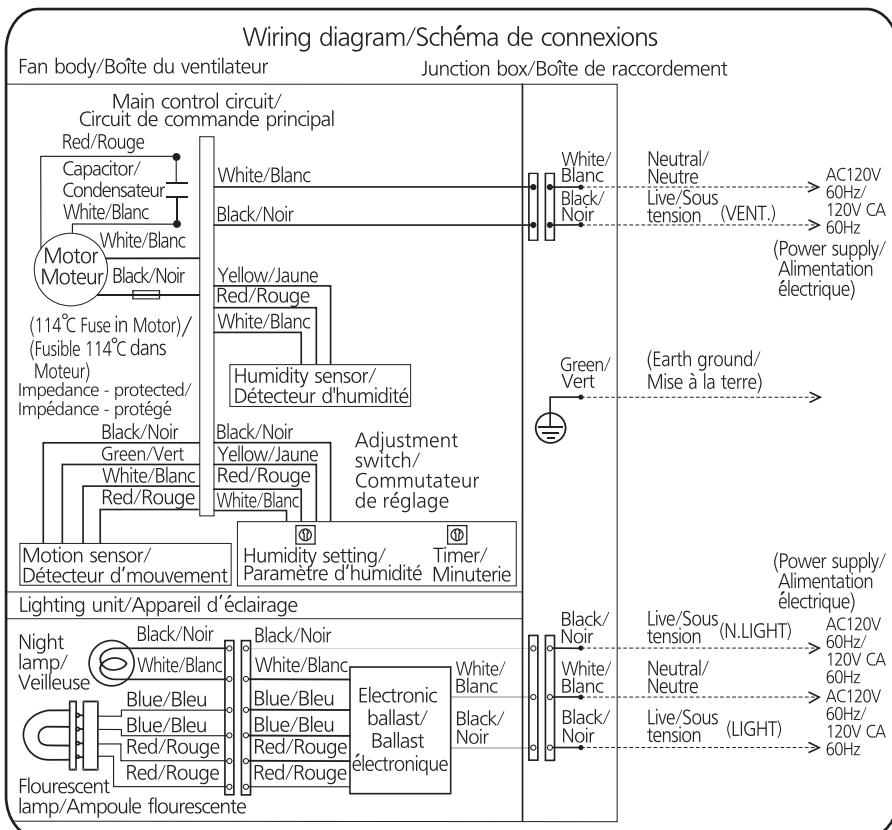

4. Parts List

FV-08VQC5
FV-11VQC5

No.	Part No.	Part Name	Q'ty	Remark
1	FFV1600111S	Frame Assembly	1	
2	FFV0420027S	Bracket Cover	1	
3	FFV0800001S	Casing Support	3	
4	FFV0000120S	Adapter Assembly	1	
5	FFV0900052S	Connector Plate	1	
6	FFV0900049S	Connector Assy V	1	⚠
7	FFV3402103S	Earth Lead Wire Assy	1	⚠
8	FFV2800012S	Junction Cover	1	
9	FFV0760028S	Capacitor Box	1	⚠
10	FFV3702214S	Motor Assembly	1	For FV-08VQC5 ⚠
(10)	FFV3702215S	Motor Assembly	1	For FV-11VQC5 ⚠
11	FFV3730089S	Motor Support	1	
12	FFV0400103S	Blade	1	⚠
13	FFV7020021S	Nut	1	
14	FFV0790077S	Casing	1	⚠
15	FFV4300131S	Orifice	1	⚠
16	FFV2220053S	Humid Sensor Assembly	1	
17	FFV5530065S	Switch Assembly	1	
18	FFV3420031S	Grille Unit	1	Not Include Sensor Box Assy ⚠
19	FFV2520025S	Insulation Plate	1	
20	FFV5500028S	Sensor Box Assembly	1	⚠
21	FFV5560036S	Spring Stopper	1	
22	FFV5560017S	Spring	2	
23	FFV2220051S	Sensor Cover	1	
24	FFV3740021S	Main PCB Box	1	⚠
25	FFV3740022S	Main PCB	1	⚠
26	FFV4620077S	Power Lead Wire	1	⚠
27	FFV3740023S	Main PCB Cover	1	⚠
28	FFV3702241S	Motor Unit	1	For FV-08VQC5 ⚠
(28)	FFV3702242S	Motor Unit	1	For FV-11VQC5 ⚠
29	FFV0750203S	Capacitor	1	For FV-08VQC5 ⚠
(29)	FFV0750206S	Capacitor	1	For FV-11VQC5 ⚠
30	FFV0900024S	Connector	4	⚠
31	FFV3700330S	Motor Lead Wire	1	⚠
32	FFV4020685S	Name Plate	1	For FV-08VQC5
(32)	FFV4020686S	Name Plate	1	For FV-11VQC5
33	FFV1320001S	ESP Mark	1	
34	FFV0810010S	Warning Label	1	
35	FFV2260003S	UL Mark	1	
36	FFV2260002S	HVI Mark	1	
37	FFV6730045S	Warning Label	1	
38	FFV5720015S	Scale Tape	1	

4. Parts List

FV-08VQC5

FV-11VQC5

No.	Part No.	Part Name	Q'ty	Remark
39	FFV6730050S	Wiring Label	1	
40	FFV5710023S	Suspension Bracket I	1	
41	FFV5710024S	Suspension Bracket II	1	
42	FFV5710018S	Suspension Bracket IV	1	
43	FFV5710019S	Suspension Bracket III	1	
44	FFV2540120S	Installation Instruction	1	English,For CA Market/USA Market
45	FFV2540121S	Installation Instruction	1	French,For USA Market
(45)	FFV2540122S	Installation Instruction	1	Spanish,For CA Market
46	FFV0010200S	Accessory A	1	
47	FFV4710210S	Grille Case Assembly	1	
48	FFV4710322S	Right Pad	1	
49	FFV4710323S	Left Pad	1	
50	FFV4710330S	Sensor Pad	1	
51	FFV9000983S	Packing Case Assy	1	For FV-08VQC5
(51)	FFV9000984S	Packing Case Assy	1	For FV-11VQC5
A	FFV7000065S	Bind Screw	6	
B	FFV7000108S	Truss Tap Screw	5	
C	FFV7000089S	Truss Tap Screw	20	
D	FFV7000168S	Screw Assembly	1	Include Spring Washer&P.R Washer⚠
E	FFV7000195S	Pan Tap Screw	2	
F	FFV7000074S	Truss Tap Screw	1	
G	FFV7000140S	Pan Tap Screw	2	
H	FFV7000145S	Truss Tap Screw	4	

4. Parts List

FV-08VQCL5

FV-11VQCL5

No.	Part No.	Part Name	Q'ty	Remark
1	FFV1600111S	Frame Assembly	1	
2	FFV0420027S	Bracket Cover	1	
3	FFV0800001S	Casing Support	3	
4	FFV0000121S	Adapter Assembly	1	
5	FFV0900048S	Connector Plate	1	
6	FFV0900049S	Connector Assy V	1	⚠
7	FFV3402103S	Earth Lead Wire Assy	1	⚠
8	FFV2800012S	Junction Cover	1	
9	FFV0760028S	Capacitor Box	1	⚠
10	FFV3702217S	Motor Assembly	1	For FV-08VQCL5 ⚠
(10)	FFV3702215S	Motor Assembly	1	For FV-11VQCL5 ⚠
11	FFV3730086S	Motor Support	1	
12	FFV0400103S	Blade	1	⚠
13	FFV7020021S	Nut	1	
14	FFV0790077S	Casing	1	⚠
15	FFV0900039S	Connector Assy L	1	⚠
16	FFV2220053S	Humid Sensor Assembly	1	
17	FFV5530065S	Switch Assembly	1	
18	FFV3470003S	Ballast Assembly	1	⚠
19	FFV3420033S	Grille Unit	1	Not Include Sensor Box Assy ⚠
20	FFV3420025S	Light Cover Assembly	1	
21	FFV3420026S	Lamp Holder Section	1	⚠
22	FFV3420027S	Fluorescent Lamp	1	⚠
23	FFV3420005S	Night Lamp	1	⚠
24	FFV5500028S	Sensor Box Assembly	1	⚠
25	FFV3420030S	Grille Section	1	Include Sensor Cover&Lamp Cover ⚠
26	FFV2220051S	Sensor Cover	1	
27	FFV3420029S	Lamp Cover	1	⚠
28	FFV3740021S	Main PCB Box	1	⚠
29	FFV3740022S	Main PCB	1	⚠
30	FFV4620077S	Power Lead Wire	1	⚠
31	FFV3740023S	Main PCB Cover	1	⚠
32	FFV3702243S	Motor Unit	1	For FV-08VQCL5 ⚠
(32)	FFV3702244S	Motor Unit	1	For FV-11VQCL5 ⚠
33	FFV0750203S	Capacitor	1	For FV-08VQCL5 ⚠
(33)	FFV0750204S	Capacitor	1	For FV-11VQCL5 ⚠
34	FFV0900024S	Connector	4	⚠
35	FFV3700330S	Motor Lead Wire	1	⚠
36	FFV4020687S	Name Plate	1	For FV-08VQCL5
(36)	FFV4020688S	Name Plate	1	For FV-11VQCL5
37	FFV1320001S	ESP Mark	1	
38	FFV0810010S	Warning Label	1	

4. Parts List

FV-08VQCL5

FV-11VQCL5

No.	Part No.	Part Name	Q'ty	Remark
39	FFV2260003S	UL Mark	1	
40	FFV2260002S	HVI Mark	1	
41	FFV6730045S	Warning Label	1	
42	FFV5720015S	Scale Tape	1	
43	FFV6730051S	Wiring Label	1	
44	FFV5710023S	Suspension Bracket I	1	
45	FFV5710024S	Suspension Bracket II	1	
46	FFV5710018S	Suspension Bracket IV	1	
47	FFV5710019S	Suspension Bracket III	1	
48	FFV2540123S	Installation Instruction	1	English,For CA Market/USA Market
49	FFV2540124S	Installation Instruction	1	French,For USA Market
(49)	FFV2540125S	Installation Instruction	1	Spanish,For CA Market
50	FFV0010200S	Accessory A	1	
51	FFV4710210S	Grille Case Assembly	1	
52	FFV4710322S	Right Pad	1	
53	FFV4710323S	Left Pad	1	
54	FFV4710330S	Sensor Pad	1	
55	FFV9000985S	Packing Case Assy	1	For FV-08VQCL5
(55)	FFV9000986S	Packing Case Assy	1	For FV-11VQCL5
A	FFV7000065S	Bind Screw	6	
B	FFV7000108S	Truss Tap Screw	5	
C	FFV7000089S	Truss Tap Screw	20	
D	FFV7000168S	Screw Assembly	1	Include Spring Washer&P.R Washer⚠
E	FFV7000195S	Pan Tap Screw	2	
F	FFV7000074S	Truss Tap Screw	1	
G	FFV7000079S	Pan Tap Screw	1	
H	FFV7000145S	Truss Tap Screw	4	