

Service Manual

Ventilating Fan
North America Market

FV-08VSL3
FV-10VSL3

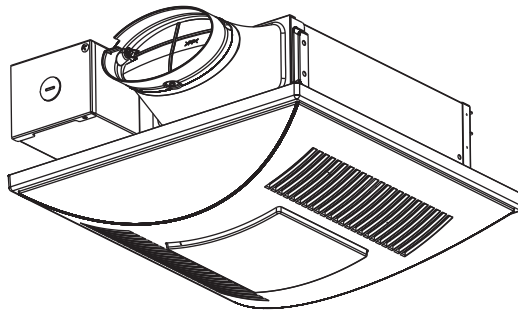

Specifications

Model No.	Air direction	Voltage (V)	Frequency (Hz)	Duct diameter (inches)	Noise (sones)	Power consumption(W)			Speed (rpm)	Air volume at 0.1"WG (CFM)	Weight (lb./kg)
						Fan	Lighting unit				
							Fluorescent lamp	Night lamp			
FV-08VSL3	Exhaust	120	60	4	1.0	22	2x13	4	825	80	7.7/3.5
FV-10VSL3	Exhaust	120	60	4	1.4	30	2x13	4	918	100	7.7/3.5

HVI Certified performance based on HVI Procedures 915,916 and 920.

! WARNING

This service information is designed for experienced repair technicians only and is not designed for use by the general public. It does not contain warnings or cautions to advise non-technical individuals of potential dangers in attempting to service a product. Products powered by electricity should be serviced or repaired only by experienced professional technicians. Any attempt to service or repair the product or products dealt with in this service information by anyone else could result in serious injury or death.

IMPORTANT SAFETY NOTICE

There are special components used in this equipment which are important for safety. These parts are marked by \triangle in the Schematic Diagrams, Exploded Views and Replacement Parts List. It is essential that these critical parts should be replaced with manufacturer's specified parts to prevent shock, fire or other hazards. Do not modify the original design without permission of manufacture. We suggest to handle such parts after the static electricity prevention. It is forbidden to touch the PCB parts by bare hands during the repairing process.

CONTENTS

	PAGE
1 Parts Identification-----	1~2
2 Wiring Diagram-----	3
3 Parts List-----	4~7

1. Parts Identification

FV-08VSL3
FV-10VSL3

Main Body Section

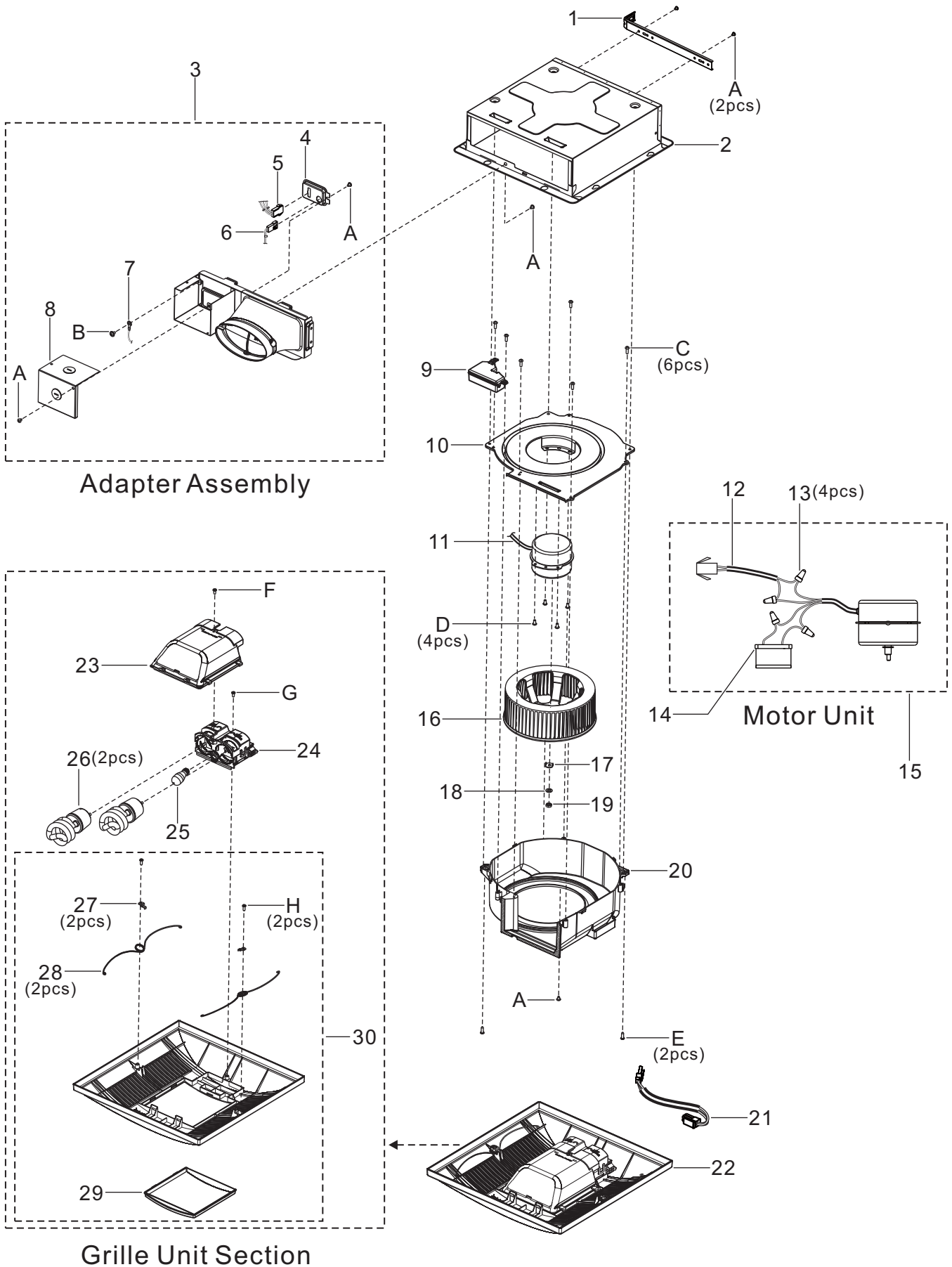

1. Parts Identification

FV-08VSL3
FV-10VSL3

Main Labels

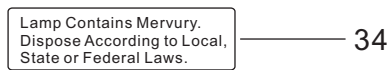
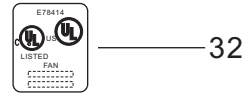

Packing Section

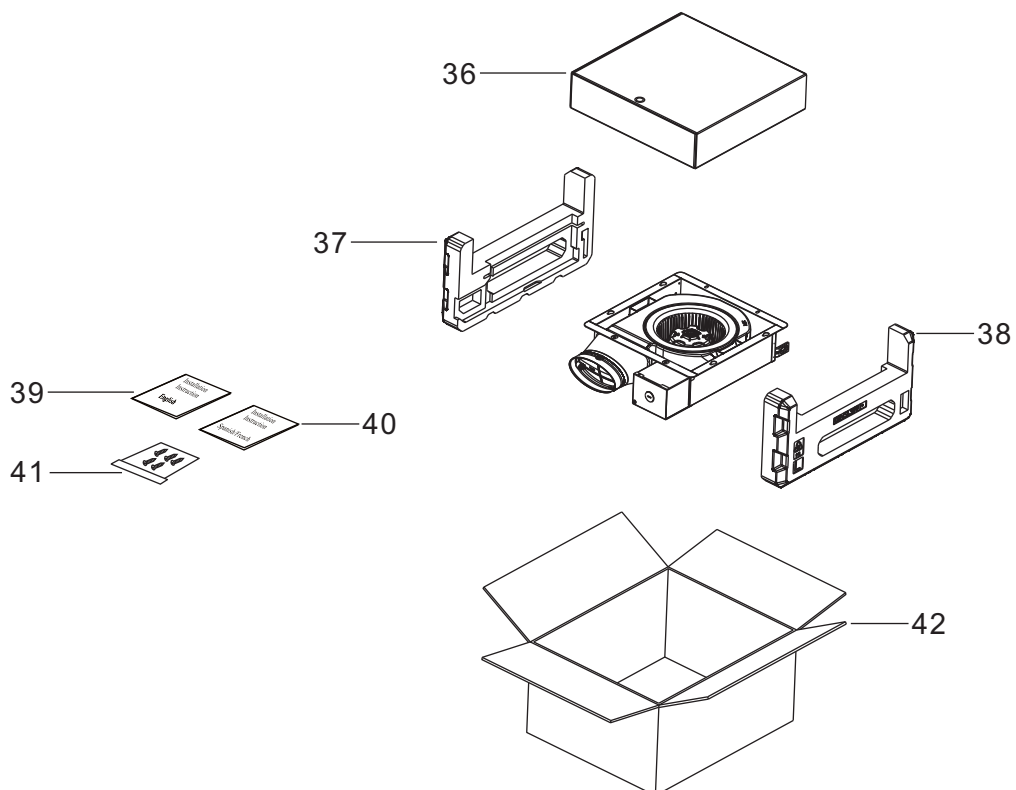

2.Wiring diagram

FV-08VSL3
FV-10VSL3

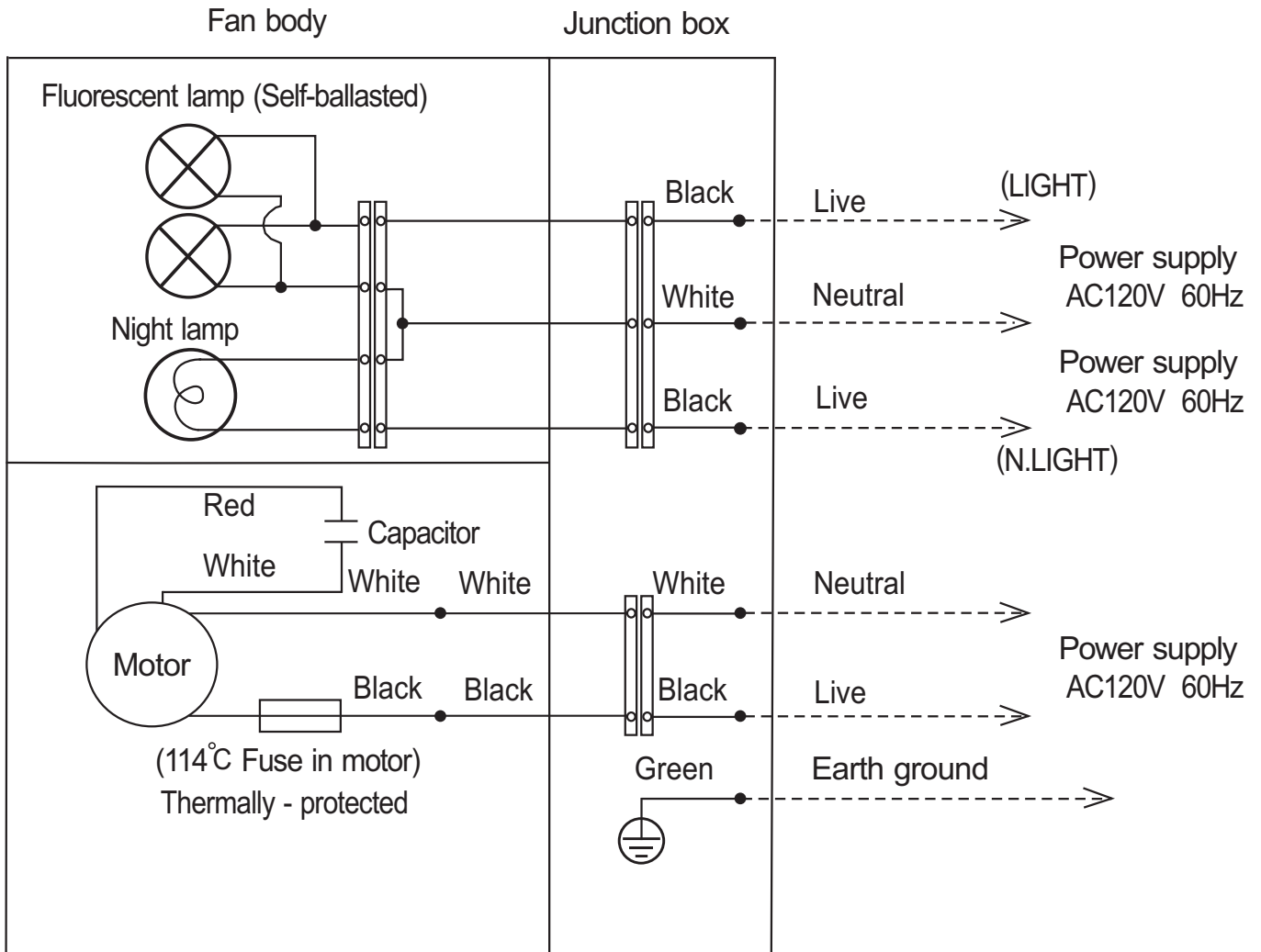

3.Parts List

FV-08VSL3

Main Body Section

No.	Part No.	Part Name	Q'ty	Remark
1	FFV5710025S	Suspension Bracket	1	
2	FFV1600132S	Frame Assembly	1	
3	FFV0000132S	Adapter Assembly	1	⚠
4	FFV0900048S	Connector Plate	1	
5	FFV0900059S	Connector Assembly(V)	1	⚠
6	FFV0900060S	Connector Assembly(L)	1	⚠
7	FFV3450010S	Earth Lead Wire	1	⚠
8	FFV2800020S	Junction Cover	1	
9	FFV0760051S	Condenser Box	1	⚠
10	FFV3730107S	Motor Support	1	Include Packing 2
11	FFV3730108S	Motor Assembly	1	⚠
12	FFV0730035S	Cord	1	⚠
13	FFV0900024S	Connector	4	
14	FFV0750219S	Condenser	1	250V~ 1.7μF ⚠
15	FFV3730109S	Motor Unit	1	⚠
16	FFV0400112S	Blade	1	⚠
17	FFV0400113S	Blade Fix Ring	1	For Fixing Blade
18	FFV7010058S	Undee Washer	1	For Fixing Blade
19	FFV7020024S	Hexagon Nut	1	For Fixing Blade
20	FFV0790104S	Casing	1	Include Packing 1 ⚠
21	FFV0730036S	Cord Assembly B	1	⚠
22	FFV3420073S	Grille Unit Section	1	⚠
23	FFV3420066S	Light Kit Cover Assembly	1	⚠
24	FFV3420071S	Lamp Holder Section	1	⚠
25	FFV3420005S	Night Lamp	1	⚠
26	FFV3420067S	Fluorescent Lamp	2	⚠
27	FFV5560028S	Spring Set Plate	2	
28	FFV3420074S	Grille Spring	2	
29	FFV3420075S	Lamp Cover	1	⚠
30	FFV3420076S	Grille Unit	1	⚠
A	FFV7000108S	Truss Tap Screw	6	
B	FFV7000203S	Earth Lead Wire Screw	1	Include Spring Washer ⚠
C	FFV7000089S	Truss Tap Screw	6	For Fixing Condenser Box&Motor Support
D	FFV7000074S	Truss Tap Screw	4	For Fixing Motor Assembly

3.Parts List

FV-08VSL3

Main Body Section

No.	Part No.	Part Name	Q'ty	Remark
E	FFV7000080S	Plus Bind Screw	2	For Fixing Casing
F	FFV7000191S	Bind Screw	1	For Fixing Light Kit Cover Assembly
G	FFV7000105S	Pan Tap Screw	1	For Fixing Lamp Holder Section
H	FFV7000140S	Pan Tap Screw	2	For Fixing Spring Set Plate

Main Labels

No.	Part No.	Part Name	Q'ty	Remark
31	FFV4020792S	Name Plate	1	Stuck On Casing
32	FFV2260003S	UL Mark	1	Stuck On Frame Assembly
33	FFV0810011S	Caution Label 1	1	Stuck On Frame Assembly
34	FFV6730056S	Warning Label	1	Stuck On Grille Unit
35	FFV4730001S	T24 Mark Label	1	Stuck On Grille Unit

Packing Section

No.	Part No.	Part Name	Q'ty	Remark
36	FFV4710365S	Grille Case Assembly	1	
37	FFV4710366S	Right Pad	1	
38	FFV4710367S	Left Pad	1	
39	FFV2540166S	Installation Instructions	1	English,For USA Market / CANADA Market
40	FFV2540167S	Installation Instructions	1	Spanish,For USA Market
(40)	FFV2540168S	Installation Instructions	1	French,For CANADA Market
41	FFV0010231S	Accessory A	1	
42	FFV9001071S	Packing Case Assembly	1	

3.Parts List

FV-10VSL3

Main Body Section

No.	Part No.	Part Name	Q'ty	Remark
1	FFV5710025S	Suspension Bracket	1	
2	FFV1600132S	Frame Assembly	1	
3	FFV0000132S	Adapter Assembly	1	⚠
4	FFV0900048S	Connector Plate	1	
5	FFV0900059S	Connector Assembly(V)	1	⚠
6	FFV0900060S	Connector Assembly(L)	1	⚠
7	FFV3450010S	Earth Lead Wire	1	⚠
8	FFV2800020S	Junction Cover	1	
9	FFV0760051S	Condenser Box	1	⚠
10	FFV3730107S	Motor Support	1	Include Packing 2
11	FFV3730110S	Motor Assembly	1	⚠
12	FFV0730035S	Cord	1	⚠
13	FFV0900024S	Connector	4	
14	FFV0750220S	Condenser	1	250V~ 2.4μF ⚠
15	FFV3730111S	Motor Unit	1	⚠
16	FFV0400112S	Blade	1	⚠
17	FFV0400113S	Blade Fix Ring	1	For Fixing Blade
18	FFV7010058S	Undee Washer	1	For Fixing Blade
19	FFV7020024S	Hexagon Nut	1	For Fixing Blade
20	FFV0790104S	Casing	1	Include Packing 1 ⚠
21	FFV0730036S	Cord Assembly B	1	⚠
22	FFV3420073S	Grille Unit Section	1	⚠
23	FFV3420066S	Light Kit Cover Assembly	1	⚠
24	FFV3420071S	Lamp Holder Section	1	⚠
25	FFV3420005S	Night Lamp	1	⚠
26	FFV3420067S	Fluorescent Lamp	2	⚠
27	FFV5560028S	Spring Set Plate	2	
28	FFV3420074S	Grille Spring	2	
29	FFV3420075S	Lamp Cover	1	⚠
30	FFV3420076S	Grille Unit	1	⚠
A	FFV7000108S	Truss Tap Screw	6	
B	FFV7000203S	Earth Lead Wire Screw	1	Include Spring Washer ⚠
C	FFV7000089S	Truss Tap Screw	6	For Fixing Condenser Box&Motor Support
D	FFV7000074S	Truss Tap Screw	4	For Fixing Motor Assembly

3.Parts List

FFV-10VSL3

Main Body Section

No.	Part No.	Part Name	Q'ty	Remark
E	FFV7000080S	Plus Bind Screw	2	For Fixing Casing
F	FFV7000191S	Bind Screw	1	For Fixing Light Kit Cover Assembly
G	FFV7000105S	Pan Tap Screw	1	For Fixing Lamp Holder Section
H	FFV7000140S	Pan Tap Screw	2	For Fixing Spring Set Plate

Main Labels

No.	Part No.	Part Name	Q'ty	Remark
31	FFV4020793S	Name Plate	1	Stuck On Casing
32	FFV2260003S	UL Mark	1	Stuck On Frame Assembly
33	FFV0810011S	Caution Label 1	1	Stuck On Frame Assembly
34	FFV6730056S	Warning Label	1	Stuck On Grille Unit
35	FFV4730001S	T24 Mark Label	1	Stuck On Grille Unit

Packing Section

No.	Part No.	Part Name	Q'ty	Remark
36	FFV4710365S	Grille Case Assembly	1	
37	FFV4710366S	Right Pad	1	
38	FFV4710367S	Left Pad	1	
39	FFV2540166S	Installation Instructions	1	English,For USA Market / CANADA Market
40	FFV2540167S	Installation Instructions	1	Spanish,For USA Market
(40)	FFV2540168S	Installation Instructions	1	French,For CANADA Market
41	FFV0010231S	Accessory A	1	
42	FFV9001072S	Packing Case Assembly	1	