

Housings

Outdoor Environmental Housing

DESCRIPTION

The POH1100 series of environmental and rugged camera housings are designed for Panasonic fixed body analog and network cameras. The housing is constructed of impact resistant polycarbonate and has a wall /pole mount bracket comprised of die cast aluminum with a durable powder coat finish.

POH1100 - Indoor housing for Analog and Network cameras

POH1100HB - Outdoor housing with heater and blower for use with analog and IP cameras

POH1100NWME - Outdoor housing with heater and blower, for use with network cameras, PoE+ (IEEE802.3at)

Made for Panasonic Canada Inc.
5770 Ambler Drive Mississauga, Ontario L4W 2T3
Phone: (905) 624-5010 Fax: (905) 238-2350

SECURITY
YOU CAN COUNT ON.

POH1100 Series



Sunshield:
POH1100 (not included)

POH1100HB / POH1100NWME (Included)

Electrical Specifications	
Input Power	PoE (IEEE802.3at) or 12/24V input model
Power Consumption	
24VAC	27 watts: heater & blower (POH1100HB)
12VDC	10 watts: heater & blower (POH1100HB)
PoE	25 watts: Camera, heater & blower (POH1100NWME)
Power Output	24Vac or 12Vdc power to the camera (POH1100HB)
	PoE IEEE802.3af compliant Panasonic cameras (POH1100NWM)
General Specifications	
Product Dimensions	455 x 145 x 267mm (17.9" x 5.7" x 10.5")
Product Weight	2.04Kg (4.5Lbs.) (without camera)
Enclosure Construction	
Body and Top:	Polycarbonate
Mount Bracket:	Cast aluminum
Window:	Scratch resistant polycarbonate
Mounting Pattern:	51 x 108mm (2" x 4.25")
Mounting Style:	Wall or Pole
Maximum Camera Length	280mm (11")
Camera included	No
Shipping Dimensions	209 x 298 x 495mm (8.25" x 11.75" x 19.5")
Shipping weight	2.72Kg (6.5 Lbs.)
Environmental Specifications	
Operating Temperature - POH1100HB	-45°C to 50°C (-50°F to 122°F)
Heater activates at:	15.5°C (60°F)
Heater de-activates at:	27°C (80°F)
Blower	Yes
Effective Projected area	101in ²
IP Rating (Weather Rating)	IP66 / NEMA 4
Maximum Wind Load	240kph (150mph)
Certifications / Ratings	
CE / CUL / IK10 rated / NEMA Rating / RoHS / UL listed / WEEE / REACH	

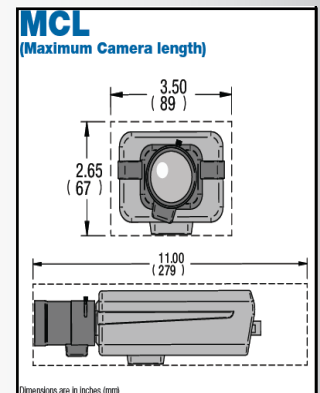

FEATURES

- wall / pole mount bracket equipped with 3/4" conduit knockout
- Side hinges for ease of access when focusing and adjusting the cameras
- Tool free snap in camera tray
- Back hinge break-away mount for to allow cable pass through
- notched mount for pole mount with banding straps (not included)
- Enhanced airflow design
- IP66 ingress protection to eliminate water ingress
- IK10 impact rated for rugged environments

Panasonic
www.panasonic.ca