

## Split System Submittal Data

System: **36PEU2U6** Indoor: **S-36PU2U6** Outdoor: **U-36PE1U6**

Grill Assembly: **CZ-36KPU3U**

Single Zone Heat Pump - Ceiling Suspended

Job Name: \_\_\_\_\_  
 Location: \_\_\_\_\_  
 Engineer: \_\_\_\_\_  
 Submitted to: \_\_\_\_\_  
 Submitted by: \_\_\_\_\_  
 Reference: \_\_\_\_\_

Approval: \_\_\_\_\_  
 Date: \_\_\_\_\_  
 Construction: \_\_\_\_\_  
 Unit#: \_\_\_\_\_  
 Drawing#: \_\_\_\_\_

Rated Conditions	
Indoor	Outdoor
80°F DB / 67°F WB	95°F DB / 75°F WB
70°F DB / 60°F WB	47°F DB / 43°F WB
70°F DB / 60°F WB	17°F DB / 15°F WB

General Data	
<b>Power (V/P/Hz)</b>	<b>230/208/1/60</b>
Circuit Ampacity (A)	15-30 Indoor-Outdoor
Fuse Size, Max. (A)	15-30 Indoor-Outdoor
<b>Compressor</b>	DC Rotary Inverter
No. Used	1
R.L. Amps - L.R. (A)	15.7 - 17.5

Outdoor Unit	
Fan type	Propeller
No. used	1
Dia & Length (in.)	18-7/64
Type Drive - No. Speeds	DC Motor-Variable
No. Poles (RPM)	8 - 800
No. Motors (W)	1 - 90
CFM (High)	1,942
F.L. Amps (A)	13.8
<b>Coil Type</b>	Aluminum Fin & Copper Pipe
Fin Type - Pipe Type	Slit Plate - Inner Rifled
Rows - F.P.I.	1 - 15.9
Face Area (sq.ft.)	7.26
Tube Size (in)	3/8"

Indoor Unit	
Fan Type	Turbo
No. used	1
Fan ( diameter)	19-9 / 32"
No. Speeds	3 & Auto
No. Poles (RPM, High)	8P - 590
No. Motors (W)	DC 1-90
CFM (Hi/Med/Lo)	1,165/953/742
Indoor Sound Rating (Hi) (dB-A)	44
F.L. Amps (A)	0.65



<b>Coil Type</b>	Aluminum Plate Fin & Copper Tube
Fin Type - Pipe Type	Slit Plate - Inner Rifled
Rows - Fins per inch	2 - 3/64"
Face Area (sq. ft.)	5.62
Tube Size (in.)	9/32"
Drain Connection Size (in.)	1-1/4"
<b>Refrigerant</b>	R410A
Lbs. - R410a	6.2
Control	Electric Expansion Valve
Connection	Flare
Line Length, Max (ft.)	165
Line Difference, Max (ft.)	50 (outdoor lower), 100 (outdoor higher)
Line Size (in. O.D. Discharge)	3/8"
Line Size (in. O.D. Suction)	5/8"
<b>Dimensions (HxWxD)</b>	
Indoor Unit (Uncrated) (in.)	10-5/64 x 33-5/64 x 33-5/64
Outdoor Unit (Uncrated) (in.)	30-23/32 x 37 x 13 3/8
<b>Weight (lbs.)</b>	
{Indoor} Net	53
{Outdoor} Net	128

### Performance Data @ ARI Standard Conditions (230/208V)

Cooling	
Total Capacity (BTU/H)	32,600 (9,500 - 32,600)
Sensible Capacity (BTU/H)	24,800
Latent Capacity (BTU/H)	7,800
SEER	16
Dehumidification (Pints/H)	4.4
Amps (A)	18.4/20.3
Power Inputs (W)	3,940/3,940
Outdoor Sound Rating (dB-A) High	49
Heating	
High Heating @47°	37,000
Low Heating @17°	18,200
Total Capacity (BTU/H)	37,000 (8,000 - 37,000)
HSPF	9.0
Amps (A)	15.8/17.5
Power Inputs (W)	3,400/3,400
Back-up Strip Heater (KW)	N/A
Outdoor Sound Rating (dB-A) High	52

### Features

Controls	Microprocessor
Remote Controller	Remote Purchased Separately
Temperature Control	Thermostat
Timer	24 Hr. Program
Night Setback	N/A
Air Louver, Horizontal	N/A
Air Louver, Vertical	Automatic
Power Failure Automatic Restart	Built-In
Heating/Cooling Automatic Changeover	Built-In
Self-Diagnosis	Built-In
Air Filter	Washable, Anti-Mold

### Options

Refrigerant Line Set	Available
Fresh Air Intake	N/A
Econavi Available With Use Of	CZ-RTC3,4,5 & CZ-CENCS1
Indoor Frame Extension	N/A
Condensate Drain Pump	Built in
Non-Removeable Remo-con Bracket	Available

### Operating Range

Operating Range	Indoor Air Intake Temp	Outdoor Air Intake Temp
Cooling (Max)	95F DB/71F WB	115F DB
Cooling (Min)	67 DB/57F WB	0F DB (No Lockout)
Heating (Max)	80F DB/67F WB	75F DB/65F WB
Heating (Min)	-DB/-WB	(-4)F DB (No Lockout)



# Indoor Dimensions

## ■ Preparation for Suspending

This unit uses a drain pump. Use a carpenter's level to check that the unit is level.

## ■ Suspending the Indoor Unit

Fix the suspension bolts securely in the ceiling using the method shown in the diagrams by attaching them to the ceiling support structure, or by any other method that ensures that the unit will be securely and safely suspended.

**Note:** For DC Fan Motor Tap Setting procedure for 4-Way Cassette 36" x 36", see page 1-157.

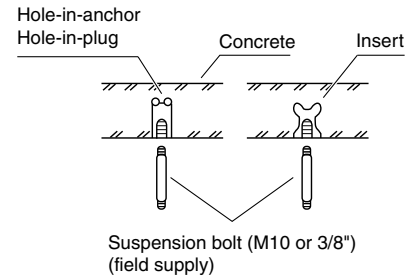

Type		A	B	C	D
26	inch	30-15/16	29-21/64	33-55/64 to 35-53/64	33-55/64 to 35-53/64
	mm	786	745	860 to 910	860 to 910
36, 42	inch	30-15/16	29-21/64	33-55/64 to 35-53/64	33-55/64 to 35-53/64
	mm	786	745	860 to 910	860 to 910

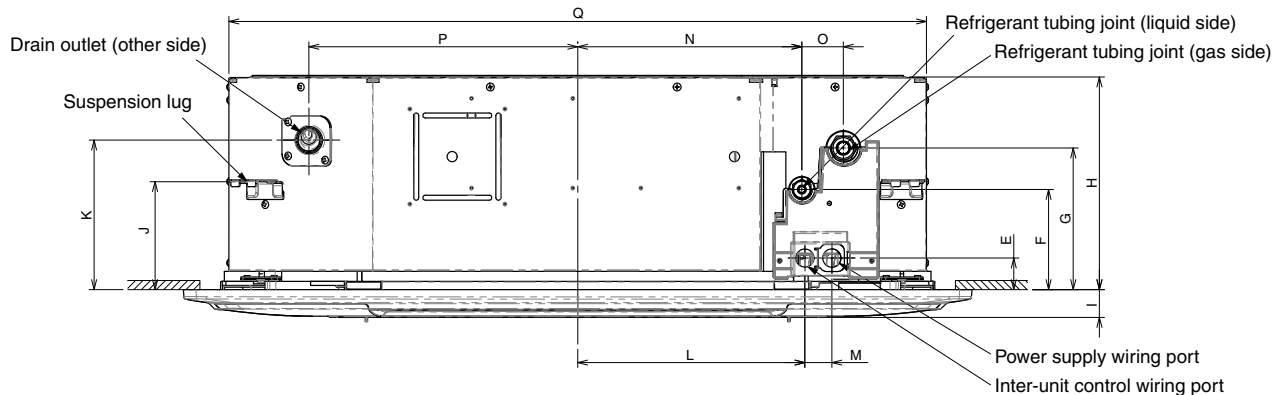
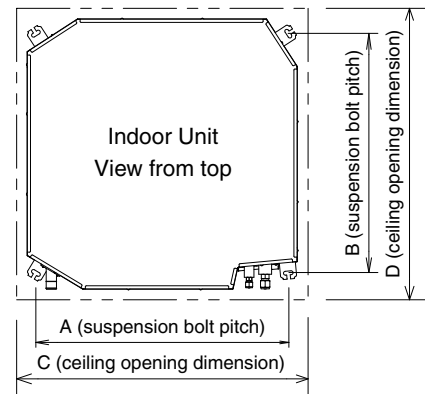

Type		E	F	G	H	I	J	K	L	M	N	O	P	Q
26	inch	1-1/2	4-49/64	6-47/64	10-5/64	1-5/16	5-1/8	7-3/32	10-25/32	1-9/32	10-5/8	1-31/32	12-3/4	33-5/64
	mm	38	121	171	256	33.5	130	180	274	32.5	270	50	323.8	840
36, 42	inch	1-1/2	4-49/64	6-47/64	12-9/16	1-5/16	5-1/8	7-3/32	10-25/32	1-9/32	10-5/8	1-31/32	12-3/4	33-5/64
	mm	38	121	171	319	33.5	130	180	274	32.5	270	50	323.8	840



# Outdoor Dimensions

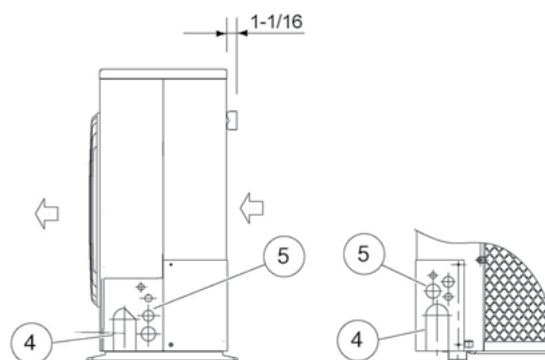
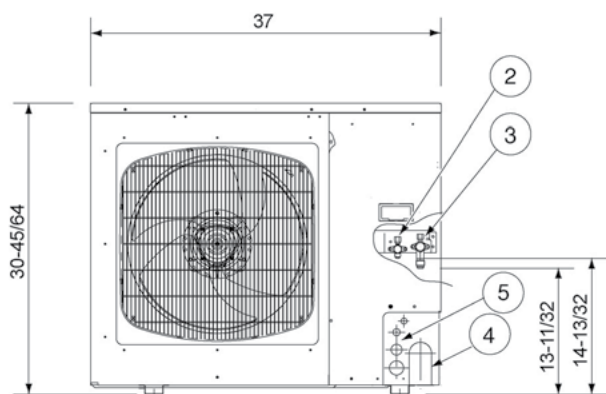
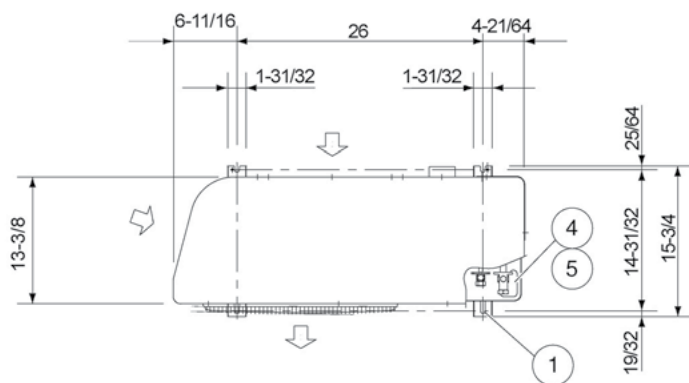

Dimension: inch

①	Hole for anchor bolt (4-R6.5) / Anchor bolt: M10
②	Refrigerant tube joint (liquid line tube) • Flare connection 3/8 in (9.52 mm)
③	Refrigerant tube joint (gas line tube) • Flare connection 5/8 in (15.88 mm)
④	Refrigerant tubing inlet (knock-out hole)
⑤	Power supply inlet (knock-out hole $\phi 38$ , $\phi 29$ , $\phi 19$ , $\phi 16$ mm)

