

# Installation Manual

## Air Conditioner

**Indoor Unit**  
 CS-E12RB4UW  
 CS-E18RB4UW

**Outdoor Unit**  
 CU-E12RB4U  
 CU-E18RB4U

**Destination**  
 USA  
 Canada

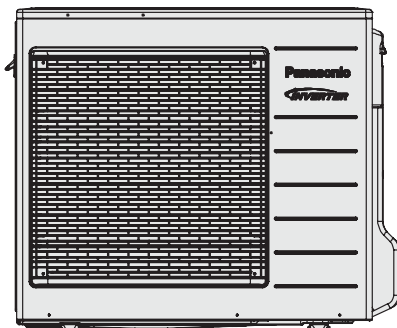
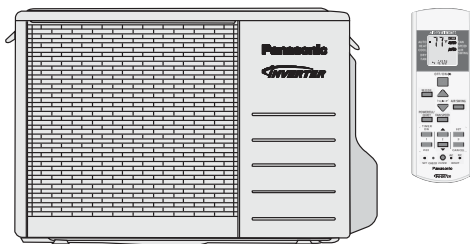

### **⚠ WARNING**

This service information is designed for experienced repair technicians only and is not designed for use by the general public. It does not contain warnings or cautions to advise non-technical individuals of potential dangers in attempting to service a product. Products powered by electricity should be serviced or repaired only by experienced professional technicians. Any attempt to service or repair the products dealt with in this service information by anyone else could result in serious injury or death.

### **IMPORTANT SAFETY NOTICE**

There are special components used in this equipment which are important for safety. These parts are marked by **⚠** in the Schematic Diagrams, Circuit Board Diagrams, Exploded Views and Replacement Parts List. It is essential that these critical parts should be replaced with manufacturer's specified parts to prevent shock, fire or other hazards. Do not modify the original design without permission of manufacturer.

### **⚠ PRECAUTION OF LOW TEMPERATURE**

In order to avoid frostbite, be assured of no refrigerant leakage during the installation or repairing of refrigerant circuit.

# Panasonic<sup>®</sup>

# 11. Installation Instruction

## 11.1 Indoor Unit

### 11.1.1 Selecting the Location for the Indoor Unit

Provide a check port on the piping side ceiling for repair and maintenance.

- Install the indoor unit once the following conditions are satisfied and after receiving the customer approval.
  - 1 The indoor unit must be within a maintenance space.
  - 2 The indoor unit must be free from any obstacles in path of the air inlet and outlet, and must allow spreading of air throughout the room.
  - 3 Mount with the lowest moving parts at least 8 ft (2.4 m) above floor or grade level.

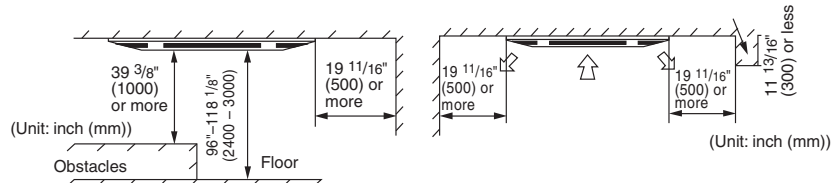

\* If the height from the floor to ceiling exceeds three meters, air flow distribution deteriorates and the effect is decreased.

<b>WARNING</b>	
4	The installation position must be able to support a load four times the indoor unit weight.
5	The indoor unit must be away from heat and steam sources, but avoid installing it near an entrance.
6	The indoor unit must allow easy draining.
7	The indoor unit must allow easy connection to the outdoor unit.
8	Place the indoor unit according to the height from the ceiling shown in the illustration below.
9	The indoor unit must be from at least 9.8 ft (3 m) away from any noise-generating equipment. The electrical wiring must be shielded with a steel conduit.
10	If the power supply is subject to noise generation, add a suppressor.
11	Do not install the indoor unit in a laundry. Electric shocks may result.

**Note** • Thoroughly study the following installation locations

- 1 In such places as restaurants and kitchens, considerable amount of oil steam and flour adhere to the turbo fan, the fin of the heat exchanger and the drain pump, resulting in heat exchange reduction, spraying, dispersing of water drops, drain pump malfunction, etc.  
In these cases, take the following actions:
  - Make sure that the ventilation fan for smoke-collecting hood on a cooking table has sufficient capacity so that it draws oily steam which should not flow into the suction of the air conditioner.
  - Make enough distance from the cooking room to install the air conditioner in such place where it may not suck in oily steam.

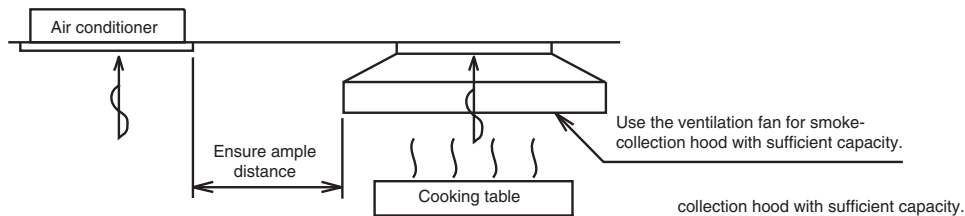

- 2 Avoid installing the air conditioner in such circumstances where cutting oil mist or iron powder exist especially in factories, etc.
- 3 Avoid places where inflammable gas is generated, flows-in, contaminated, or leaked.
- 4 Avoid places where sulphurous acid gas or corrosive gas can be generated.
- 5 Avoid places near high frequency generators.

Model Name	Height in the ceiling
E12***	11" (280 mm) or more
E18***	11" (280 mm) or more

### 11.1.2 Installation of Indoor Unit

This air conditioner uses a drain up motor. Horizontally install the unit using a level gauge.

#### CEILING OPENING DIMENSIONS AND HANGING BOLT LOCATION

The paper model for installation expand or shrink according to temperature and humidity. Check on dimensions before using it.

**Caution** During the installation, care must be taken not to damage electric wires.

- The dimensions of the paper model for installation are the same as those of the ceiling opening dimensions.
- Be sure to discuss the ceiling drilling work with the workers concerned.

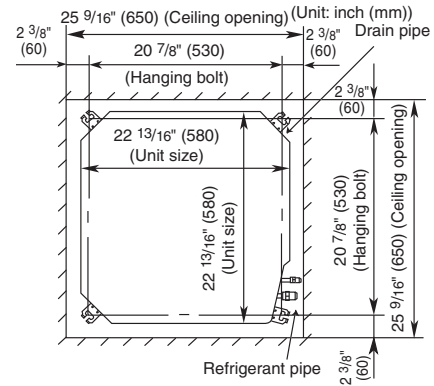

#### POSITIONS OF AIR CONDITIONER BODY AND CEILING SURFACE

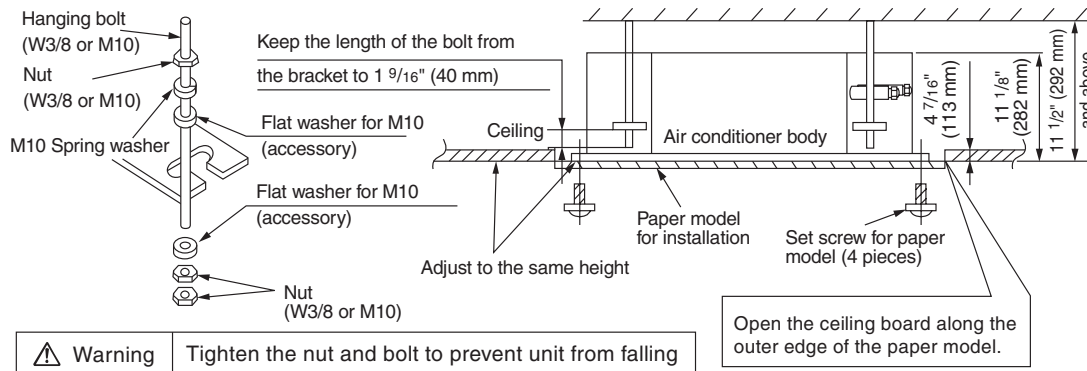

### 11.1.3 Refrigerant Piping

Refrigerant is charged to the outdoor unit. For details, see the manual for installation work of outdoor unit. (Additional charging, etc.)

- 1 Brazing for piping.
  - a. Execute brazing before tightening the flare nut.
  - b. Brazing must be executed while blowing nitrogen gas. (This prevents generation of oxidized scale in copper pipe.)
- 2 When there is a lot of brazings for long piping, install a strainer midway of the piping. (The strainer is locally supplied.)
- 3 Use clean copper pipe with inner wall surface free from mist and dust. Blow nitrogen gas or air to blow off dust in the pipe before connection.
- 4 Form the piping according to its routing. Avoid bending and bending back the same piping point more than three times. (This will result in hardening of the pipe).
- 5 After deforming the pipe, align centers of the union fitting of the indoor unit and the piping, and tighten them firmly with wrenches.
- 6 Connect pipe to the service valve or ball valve which is located below the outdoor unit.
- 7 After completed the piping connection, be sure to check if there is gas leakage in indoor and outdoor connection.

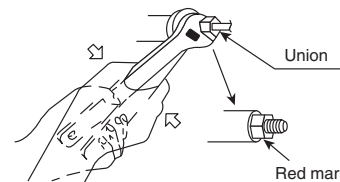

- Confirm the red mark of the union (thin side) is always at lower direction after connecting piping.

## Vacuum drying

After completing the piping connection, execute vacuum drying for the connecting piping and the indoor unit. The vacuum drying must be carried out by using the service ports of both the liquid and gas side valves.

**CAUTION** Use two wrenches and tighten with regular torque.

Do not overtighten, overtightening may cause gas leakage.	
Piping size	Torque
1/4" (6.35 mm)	13.3 lbf•ft [18 N•m (1.8 kgf•m)]
3/8" (9.52 mm)	31.0 lbf•ft [42 N•m (4.3 kgf•m)]
1/2" (12.7 mm)	40.6 lbf•ft [55 N•m (5.6 kgf•m)]
5/8" (15.88 mm)	47.9 lbf•ft [65 N•m (6.6 kgf•m)]
3/4" (19.05 mm)	73.8 lbf•ft [100 N•m (10.2 kgf•m)]

### 11.1.4 Indoor Unit Drain Piping

- During drain piping connection, be careful not to exert extra force on the drain port at the indoor unit.
- The outside diameter of the drain connection at the indoor unit is 1-1/4" (32 mm).

Piping material: Polyvinyl chloride pipe VP-25 and pipe fittings.

- Be sure to perform heat insulation on the drain piping.

Heat insulation material: Polyethylene foam with thickness more than 5/16" (8 mm) (local supply).

- Drain piping must have down-slope (1/50 to 1/100); be sure not to provide up-and-down slope to prevent reversal flow.
- Be sure to check no air trap on drain hose and to ensure smooth water flow and no abnormal sound.

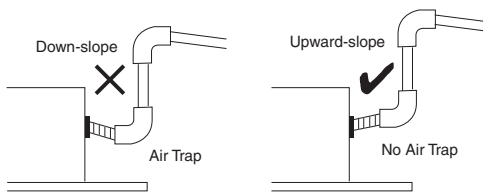
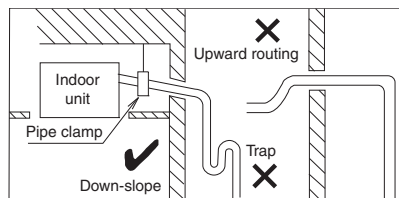

- The height of drain may be possible up to 29-1/2" (750 mm).

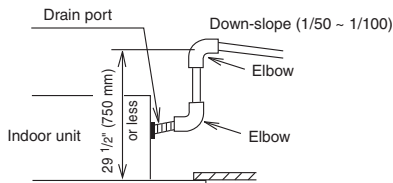

- When drain set piping, install as shown in the figure below.

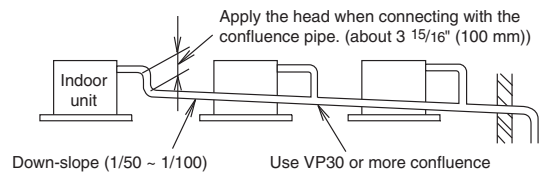

## Drain Test

The air conditioner uses a drain up motor to drain water. Use the following procedure to test the drain up motor operation.

- Connect the main drain pipe to exterior and leave it provisionally until the test comes to an end.
- Feed water to the flexible drain hose and check the piping for leakage.
- Be sure to check the drain up motor for normal operating and noise when electric wiring is complete.
- When the test is complete, connect the flexible drain hose to the drain port.
- Pour about 600-700cc of water in the drain pan of the indoor unit. (Pour from the position specified in the drawing by using a water supply bottle or other suitable tool.)
- Press the drain pump test run on PCB to start the drain motor, and verify water drainage. (The drain motor will automatically stop after operating for about five minutes.)

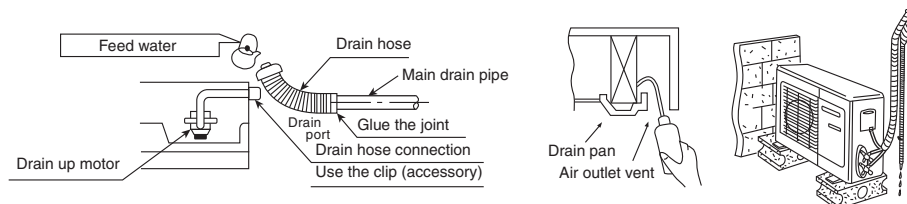

## 11.1.5 Heat Insulation

**CAUTION** Be sure to perform heat insulation on the drain, liquid and gas piping. Imperfection in heat insulation work leads to water leakage.

- 1 Use the heat insulation material for the refrigerant piping which has an excellent heat-resistance (over 248°F (120°C)).

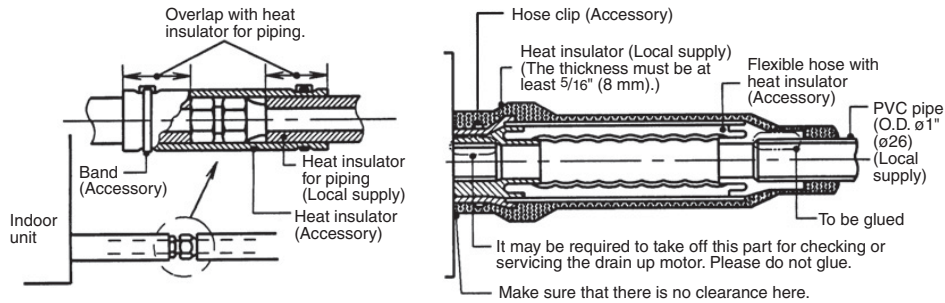

- 2 Precautions in high humidity circumstance.

This air conditioner has been tested according to the “JIS Standard Conditions with Mist” and have been confirmed that there are no faults. However, if it is operated for a long time in high humid atmosphere (dew point temperature: more than 73.4°F (23°C)), water drops are liable to fall. In this case, add heat insulation material according to the following procedure:

- Heat insulation material to be prepared... Adiabatic glass wool with thickness 3/8" to 1 3/16" (10 to 20 mm).
- Stick glass wool on all air conditioners that are located in ceiling atmosphere.
- In addition to the normal heat insulation (thickness: more than 5/16" (8 mm) for refrigerant piping (gas piping: thick piping) and drain piping, add a further of 3/8" (10 mm) to 1 3/16" (30 mm) thickness material.

### Wall seal

- When the outdoor unit is installed on a higher position than the indoor unit, install the trap so as not to instill rain water into the wall by transmitting in piping.
- Stuff the space among piping, the electric wire, and- the drain hose with “Putty” and seal the penetration wall hole. Make sure that rain water do not instill into the wall.

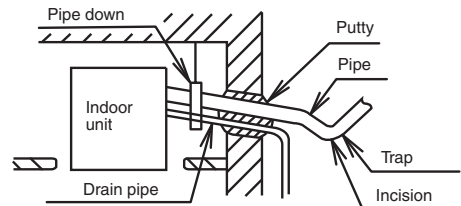

\* Put the incision at the trap part of the heat insulator (for water drain)

### 11.1.6 Connecting the Cable to the Indoor

- Open the control board cover by removing 2 pcs of screw.
- Unscrew and open the conduit cover upper case. Remove the plug and fix the conduit connector to conduit cover with lock nut.
- Connecting wire between indoor unit and outdoor unit should be UL listed or CSA approved 4 conductor UL listed or CSA approved 4 conductor wires minimum AWG16 in accordance with local electric codes. Allowable connection cable length of each indoor unit shall be 98.4 ft (30 m) or less.
- Secure the connection cable onto the control board with the holder (clamper).
- Ensure the colour of wires of outdoor unit and the terminal Nos. are the same to the indoor's respectively.
- Earth wire shall be Yellow/Green (Y/G) in colour and longer than other AC wires for safety reason.

Terminals on the indoor unit	1	2	3	
Colour of wires				
Terminals on the outdoor unit	1	2	3	

<b>WARNING</b>
This equipment must be properly earthed.

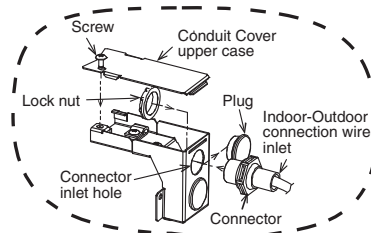
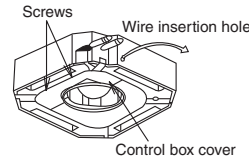

**WIRE STRIPPING, CONNECTING REQUIREMENT**

Wire stripping

No loose strand when inserted

13/32" ± 1/16" (10±1 mm)

Indoor/outdoor connection terminal board 7/32" (5 mm) or more (gap between wires)

Conductor fully inserted    Conductor over inserted    Conductor not fully inserted

ACCEPT    PROHIBITED    PROHIBITED

**WARNING** **RISK OF FIRE**  
JOINING OF WIRES MAY CAUSE OVERHEATING AND FIRE.

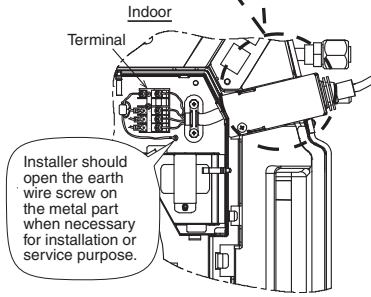

Do not joint wires

OR

OR

- ❗ Use complete wire without joining.
- ❗ Use approved socket and plug with earth pin.
- ❗ Wire connection in this area must follow to national wiring rules.

### 11.1.7 Installation of Decorative Panel

The decorative panel has its installation direction. Confirm the direction by displaying the piping side.

- 1 Remove the air inlet grille by moving the catchers to center.

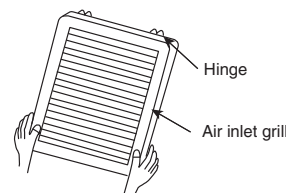
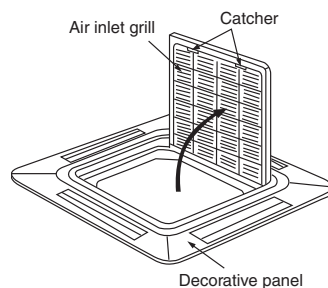

\* Hang the hinge on the hole of decorative panel. (The direction of the installation is free.)

- 2 Fitting the decorative panel
  - Temporarily secure the fixing screws (3 pcs.) before fitting the decorative panel. (For temporarily securing the front grille.)
  - Place decorative panel on the screws (3 pcs.) before fitting, move decorative panel as illustrated and tighten all the screws (4 pcs.).

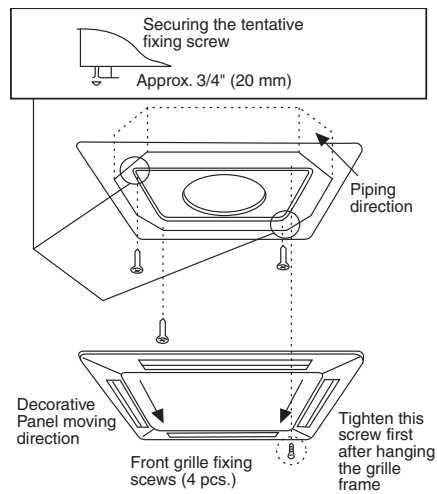

**CAUTION**

- Check beforehand the height from the ceiling to the unit.
  - The front grille fitting direction is determined by the unit direction.
  - Only use the screws with the length of 1-3/8" (35 mm) which is provided, to fix the decorative panel.
  - Do not use other screw which is longer it may cause damage to the drain-pan and other components.
- 3 Fit the decorative panel and ceiling wall together and confirm no gap in between. Readjust indoor unit height, if there is a gap between ceiling wall and decorative panel.

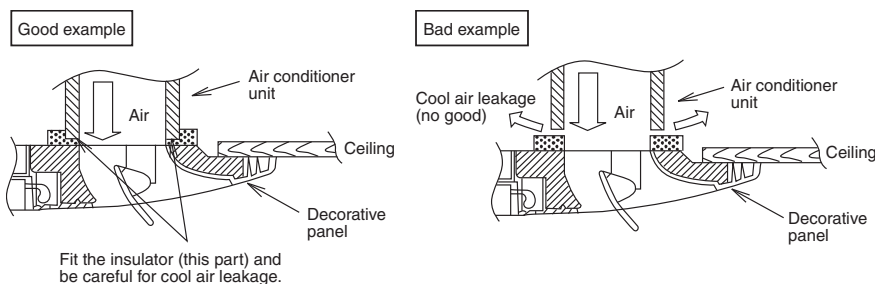

- 4 Open the indoor control box cover by removing 2 pcs of screw.
- 5 Insert firmly the connector of cosmetic louver to indoor pcb CN-STM1, CN-STM2 and CN-DISP.  
Be caution not to clamp the cord in between control board and control board cover.
- 6 After complete, install back removed part follow opposite procedure.

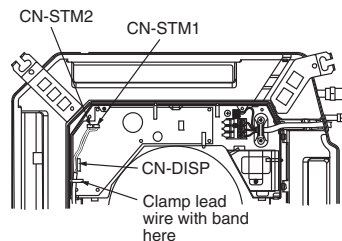

<b>WARNING</b>	Be sure to hook the air inlet grill string, to prevent grill from falling and causing injury from it.
----------------	---

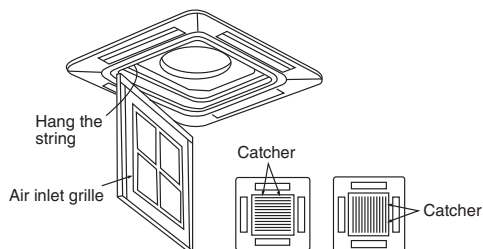

## 11.2 Outdoor Unit

### 11.2.1 Select the Best Location

- If an awning is built over the unit to prevent direct sunlight or rain, be careful that heat radiation from the condenser is not obstructed.
- There should not be any animal or plant which could be affected by hot air discharged.
- Keep the spaces indicated by arrows from wall, ceiling, fence or other obstacles.
- Do not place any obstacles which may cause a short circuit of the discharged air.
- If piping length is over the [piping length for additional gas], additional refrigerant should be added as shown in the table.

Model	Capacity (Btu/h)	Piping size		Std. Length	Max. Elevation	Min. Piping Length	Max. Piping Length	Additional Refrigerant	Piping Length for add. gas
		Gas	Liquid						
E12***	11900	1/2"	1/4"	24.6 ft (7.5 m)	49.2 ft (15 m)	9.8 ft (3 m)	65.6 ft (20 m)	0.2 oz/ft (20 g/m)	24.6 ft (7.5 m)
E18***	17500	1/2"	1/4"	24.6 ft (7.5 m)	49.2 ft (15 m)	9.8 ft (3 m)	100 ft (30.5 m)	0.3 oz/ft (25 g/m)	32.8 ft (10 m)

Example: For E12\*\*\*

If the unit is installed at 32.8 ft (10 m) distance, the quantity of additional refrigerant should be 1.64 oz (50 g) .... (32.8 - 24.6) ft x 0.2 oz/ft = 1.64 oz. ((10 - 7.5) m x 20 g/m = 50 g).

### 11.2.1.1 Indoor/Outdoor Installation Diagram

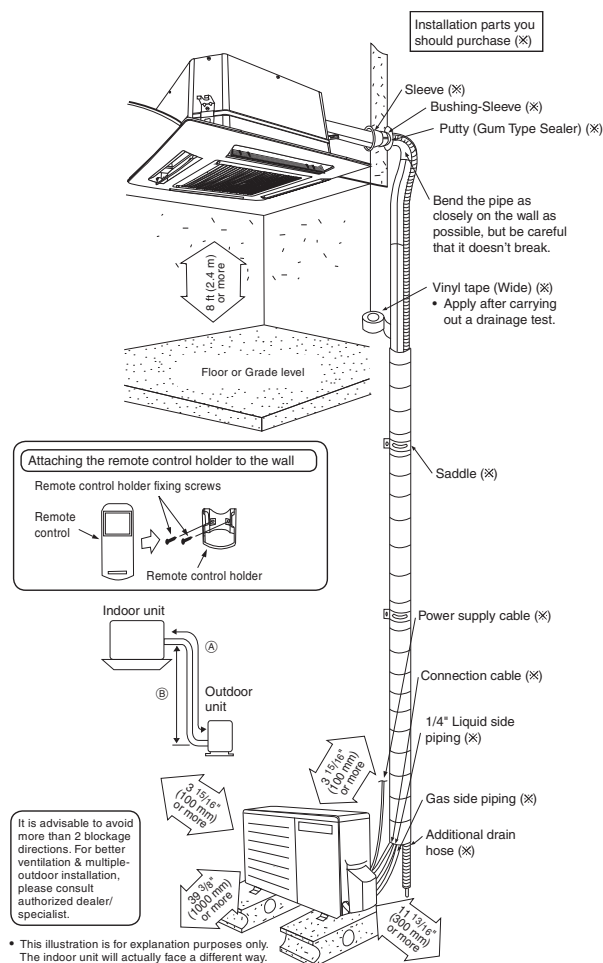

### 11.2.2 Install the Outdoor Unit

- After selecting the best location, start installation according to Indoor/Outdoor Unit Installation Diagram.
  - 1 Fix the unit on concrete or rigid frame firmly and horizontally by bolt nut (ø10 mm).
  - 2 When installing at roof, please consider strong wind and earthquake. Please fasten the installation stand firmly with bolt or nails.

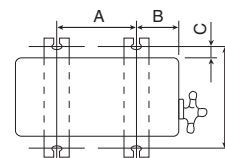

Model	A	B	C	D
E12***	22-7/16" (570 mm)	4-1/8" (105 mm)	23/32" (18.5 mm)	12-19/32" (320 mm)
E18***	24-1/8" (613 mm)	5-5/32" (131 mm)	5/8" (16 mm)	14-3/16" (360.5 mm)



## 11.2.3 Connect the Piping

### 11.2.3.1 Connecting the Piping to Indoor Unit

Please make flare after inserting flare nut (locate at joint portion of tube assembly) onto the copper pipe. (In case of using long piping)

Connect the piping

- Align the center of piping and sufficiently tighten the flare nut with fingers.
- Further tighten the flare nut with torque wrench in specified torque as stated in the table.

Do not overtighten, overtightening may cause gas leakage	
Piping size	Torque
1/4" (6.35 mm)	13.3 lbf•ft [18 N•m (1.8 kgf•m)]
3/8" (9.52 mm)	31.0 lbf•ft [42 N•m (4.3 kgf•m)]
1/2" (12.7 mm)	40.6 lbf•ft [55 N•m (5.6 kgf•m)]
5/8" (15.88 mm)	47.9 lbf•ft [65 N•m (6.6 kgf•m)]
3/4" (19.05 mm)	73.8 lbf•ft [100 N•m (10.2 kgf•m)]

### 11.2.3.2 Connecting the Piping to Outdoor Unit

Decide piping length and then cut by using pipe cutter. Remove burrs from cut edge. Make flare after inserting the flare nut (locate at valve) onto the copper pipe. Align center of piping to valve and then tighten with torque wrench to the specified torque as stated in the table.

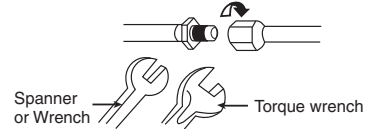

### 11.2.3.3 Connecting the Piping to Outdoor Multi

Decide piping length and then cut by using pipe cutter. Remove burrs from cut edge. Make flare after inserting the flare nut (locate at valve) onto the copper pipe. Align center of piping to valve and then tighten with torque wrench to the specified torque as stated in the table.

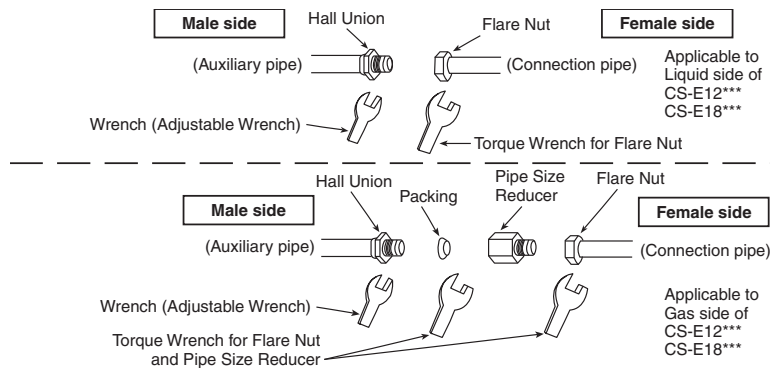

### 11.2.3.4 Gas Leak Checking

Pressure test to system to 400 PSIG with dry nitrogen, in stages. Thoroughly leak check the system. If the pressure holds, release the nitrogen and proceed to section 11.2.4.

## 11.2.4 Evacuation of the Equipment

WHEN INSTALLING AN AIR CONDITIONER, BE SURE TO EVACUATE THE AIR INSIDE THE INDOOR UNIT AND PIPES in the following procedure.

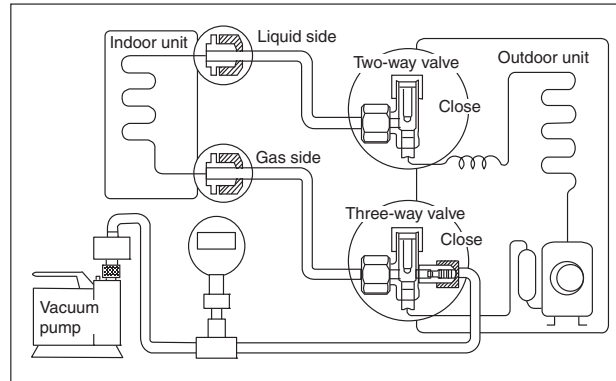

- 1 Connect a charging hose with a push pin to the Low side of a charging set and the service port of the 3-way valve.
- 2 Connect the micron gauge between vacuum pump and service port of outdoor units.
- 3 Turn on the power switch of the vacuum pump and make sure that connect digital micron gauge and to pull down to a value of 500 microns.
- 4 To make sure micron gauge a value 500 microns and close the low side valve of the charging set and turn off the vacuum pump.
- 5 Disconnect the vacuum pump house from the service port of the 3-way valve.
- 6 Tighten the service port caps of the 3-way valve at a torque of 13.3 lbf•ft (18 N•m) with a torque wrench.
- 7 Remove the valve caps of both of the 2-way valve and 3-way valve. Position both of the valves to “Open” using a hexagonal wrench (5/32" (4 mm)).
- 8 Mount valve caps onto the 2-way valve and the 3-way valve.
  - o Be sure to check for gas leakage.

- If micron gauge value does not descend 500 microns, take the following measures:
  - If the leak stops when the piping connections are tightened further, continue working from step ③.
  - If the leak does not stop when the connections are retightened, repair location of leak.
  - Do not release refrigerant during piping work for installation and reinstallation.
  - Be careful with the liquid refrigerant, it may cause frostbite.

## 11.2.5 Connect the Cable to the Outdoor Unit

- 1 Remove control board cover (Plastic and Metal), follow by particular plate (for E18\*\*\* model).
- 2 Remove top panel, follow by Control Board Cover (Plastic and Metal) (for E12\*\*\* model).
- 3 Remove plugs.
- 4 Fix the conduit connectors to the knockout holes with lock-nuts, then secure them against the side panel.
- 5 All wires pass through conduits & particular plate's opening hole.
- 6 Connecting wire between indoor unit and outdoor unit should be UL listed or CSA approved 4 conductor wires minimum AWG16 in accordance with local electric codes.
- 7 Wire connection to the power supply (208/230V 60Hz) through circuit breaker.
  - o Connect the UL listed or CSA approved wires minimum AWG14 (for E12\*\*\*) and AWG12 (for E18\*\*\*) to the terminal board, and connect the other end of the wires to ELCB / GFCI.
- 8 Connect the power supply cord and connecting wire between indoor unit and outdoor unit according to the diagram below.

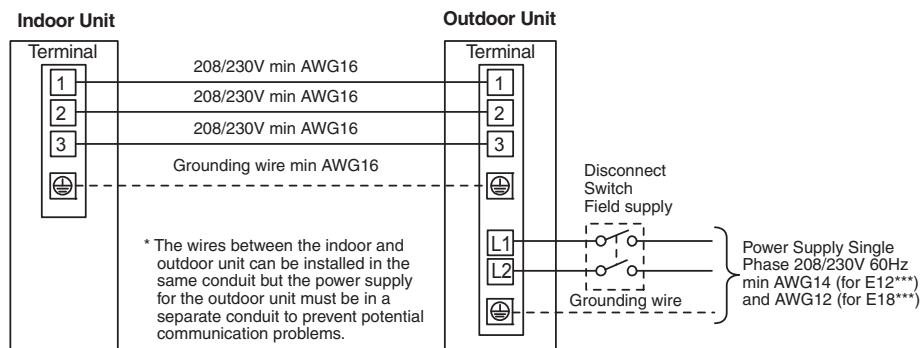

- 9 Secure the wire onto the control board with the holder (clamp).
- 10 After completing wiring connections, reattach the particular plate and control board cover (metal and plastic) to the original position with the screws.
- 11 For wire stripping and connection requirement, refer to instruction 11.1.6 of indoor unit.

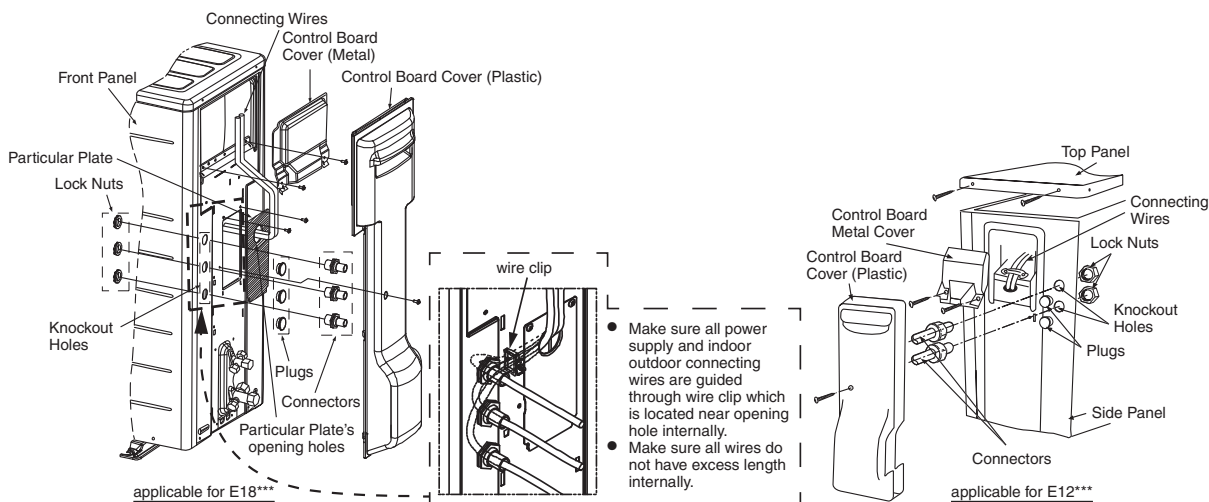
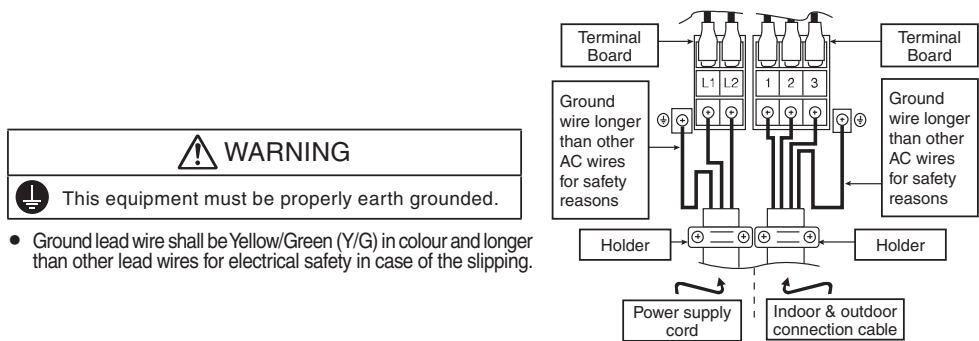

## 11.2.6 Pipe Insulation

- 1 Please carry out insulation at pipe connection portion as mentioned in Indoor/Outdoor Unit Installation Diagram. Please wrap the insulated piping end to prevent water from going inside the piping.
- 2 If drain hose or connecting piping is in the room (where dew may form), please increase the insulation by using POLY-E FOAM with thickness 1/4" (6 mm) or above.

### 11.2.6.1 Cutting and Flaring the Piping

- 1 Please cut using pipe cutter and then remove the burrs.
- 2 Remove the burrs by using reamer. If burrs is not removed, gas leakage may be caused. Turn the piping end down to avoid the metal powder entering the pipe.
- 3 Please make flare after inserting the flare nut onto the copper pipes.

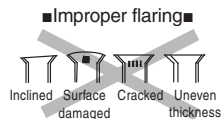
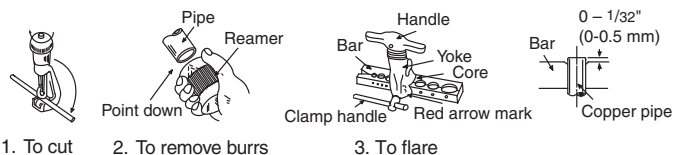

When properly flared, the internal surface of the flare will evenly shine and be of even thickness. Since the flare part comes into contact with the connections, carefully check the flare finish.

### 11.2.7 Disposal of Outdoor Unit Drain Water

- If a drain elbow is used, the unit should be placed on a stand which is taller than 1-3/16" (3 cm).
- If the unit is used in an area where temperature falls below 32°F (0°C) for 2 or 3 days in succession, it is recommended not to use a drain elbow, for the drain water freezes and the fan will not rotate.

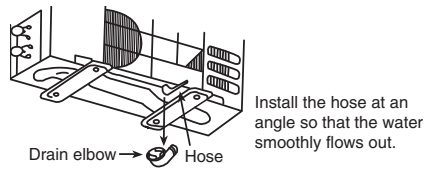

### 11.2.8 Auto Switch Operation

The following operations can be performed by pressing the "AUTO" switch.

#### 1 AUTO OPERATION MODE

The Auto operation will be activated immediately once the Auto Switch is pressed.

#### 2 TEST RUN OPERATION (FOR PUMP DOWN/SERVICING PURPOSE)

The Test Run operation will be activated if the Auto Switch is pressed continuously for more than 5 sec. to below 8 sec. A "pep" sound will occur at the fifth sec., in order to identify the starting of Test Run operation.

