

# Install Manual

## Air Conditioner

Indoor Unit  
CS-ME5SD3UA  
CS-ME7SD3UA

Destination  
USA

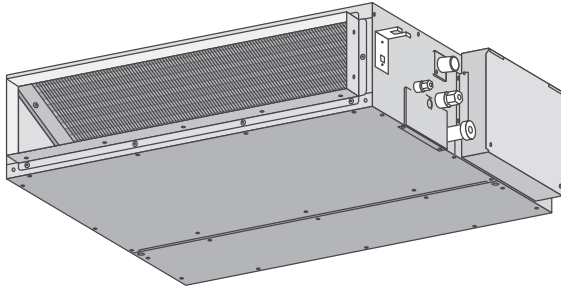

Please file and use this manual together with the service manual for Model No. CU-2E18SBU, Order No. PAPAMY1604017CE.

### WARNING

This service information is designed for experienced repair technicians only and is not designed for use by the general public. It does not contain warnings or cautions to advise non-technical individuals of potential dangers in attempting to service a product. Products powered by electricity should be serviced or repaired only by experienced professional technicians. Any attempt to service or repair the product or products dealt with in this service information by anyone else could result in serious injury or death.

### IMPORTANT SAFETY NOTICE

There are special components used in this equipment which are important for safety. These parts are marked by  in the Schematic Diagrams, Circuit Board Diagrams, Exploded Views and Replacement Parts List. It is essential that these critical parts should be replaced with manufacturer's specified parts to prevent shock, fire or other hazards. Do not modify the original design without permission of manufacturer.













### PRECAUTION OF LOW TEMPERATURE





In order to avoid frostbite, be assured of no refrigerant leakage during the installation or repairing of refrigerant circuit.

# 11. Installation Instruction

## Attached Accessories

No.	Accessory part	Qty.
1	Remote control 	1
2	Battery 	2
3	Remote control holder 	1
4	Remote control holder fixing screw 	2
5	Remote control receiver 	1

No.	Accessory part	Qty.
6	Receiver fixing screw (M4 x 39/64" (15.5 mm)) 	2
7	Clamper (band) (for receiver cable fixing) 	1
8	Receiver cable (6.56 ft (2 m)) 	1
9	Washer (for suspension fitting) 	8
10	Flare insulator (for gas pipe / liquid pipe connection) 	2

No.	Accessory part	Qty.
11	Clamper (band) (for flare & drain insulating connection) 	4
12	Drain hose (for unit & PVC pipe connection) L=131 	1
13	Hose band (for drain hose connection) 	1
14	Drain hose insulation (for drain pipe connection) 	2
15	Clamper (band) (for power supply cord)  * Be sure to fix the power supply cord with clamper (band).	1

### Required Materials

- Read the catalog and other technical materials and prepare the required materials.
- Applicable piping kit

Applicable piping kit	Piping size	
	Gas	Liquid
CZ-3F5, 7BP	3/8" (9.52 mm)	1/4" (6.35 mm)
CZ-4F5, 7, 10BP	1/2" (12.7 mm)	1/4" (6.35 mm)
CZ-52F5, 7, 10BP	5/8" (15.88 mm)	1/4" (6.35 mm)

### Other Items to be Prepared (Locally Purchased)

Product name	Remarks
Rigid PVC pipe	VP20 (outer diameter $\phi$ 1 1/32" ( $\phi$ 26); also sockets, elbows and other parts as necessary)
Adhesive	PVC adhesive
Insulation	For refrigerant piping insulation: foamed polyethylene with a thickness of 5/16" (8 mm) or more. For drain piping insulation: foamed polyethylene with a thickness of 13/32" (10 mm) or more.
Indoor/outdoor connecting cable	UL listed or CSA approved 4 conductor wires minimum AWG16
Hanging bolt related parts	Hanging bolts (M10) (4) and nuts (12), (when hanging the indoor unit)

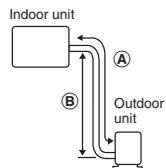
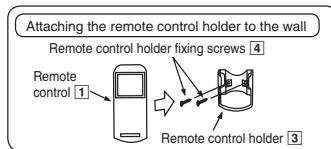
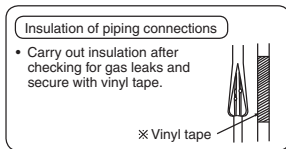

**IMPORTANT**  
Begin the installation job from the "Indoor Unit" installation.

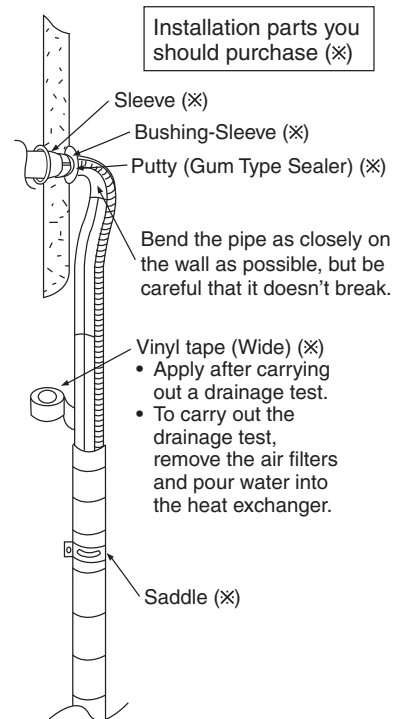

It is advisable to avoid more than 2 blockage directions. For better ventilation & multiple-outdoor installation, please consult authorized dealer/specialist.

- This illustration is for explanation purposes only. The indoor unit will actually face a different way.
- Respective outdoor unit installation procedure shall refer to instruction manual provided in the outdoor unit packaging.

## 11.1 Indoor Unit

### 11.1.1 Selecting the Installation Location

Take into consideration the following contents when creating the blueprint.

#### ■ Indoor unit installation location

- Do not install the unit in excessive oil fume area such as kitchen, workshop and etc.
- The location should be strong enough to support the main unit without vibration.
- There should not be any heat or steam source nearby.
- Drainage should be easy. Avoid locating the drain port close to ditches (domestic wastewater).
- Avoid locations above entrances and exits.
- Do not block the air intake and discharge passages.
- Select the location that enables the cool and warm air to spread out to the entire room.
- Locate the indoor unit at least 3.28 ft (1 m) or more away from a TV, radio, wireless appliance, antenna cable and fluorescent light, and 6.56 ft (2 m) or more away from a telephone.
- Recommended installation height for indoor unit shall be at least 8.27 ft (2.5 m) from floor.

### 11.1.2 To Drill a Hole in the Wall and Install a Sleeve of Piping

- 1 Insert the piping sleeve to the hole.
- 2 Fix the bushing to the sleeve.
- 3 Cut the sleeve until it extrudes about 19/32" (15 mm) from the wall.

#### ⚠ CAUTION

When the wall is hollow, be sure to use the sleeve for tube assembly to prevent pests from damaging the cables, e.g. mice biting the connection cable.

- 4 Finish by sealing the sleeve with putty or caulking compound at the final stage.

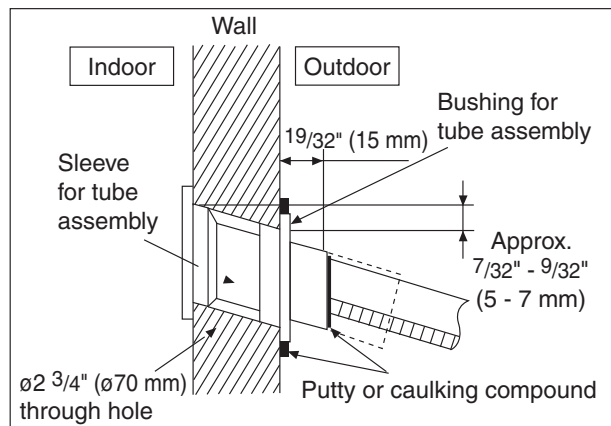

### 11.1.3 Installing the Indoor Unit (Installation Embedded in the Ceiling)

#### 11.1.3.1 Preparation Before Installation

- Always provide sufficient entry and exit space to allow installation work, inspection and unit replacement.
- Waterproof the rear surface of the ceiling below the unit in consideration of water droplets forming and dropping.

#### ⚠ CAUTION

When cooling operation is performed for an extended period under the following conditions, water droplets may form and drop. Attach locally purchased insulation (foamed polyethylene with a thickness of 7/32" (5 mm) or more) to the outside of the indoor unit before installing into the ceiling to improve heat insulation.

- Locations with a dew point inside the ceiling of 73.4°F (23°C) or more
  - Kitchens and other locations that produce large amounts of heat and steam
  - Locations where the inside of the ceiling serves as an outside air intake passage
- **When installing into a ceiling, select the unit position and airflow direction that enable the cool and warm air to spread out to the whole room.**
  - **Do not place objects that might obstruct the airflow within 3.28 ft (1 m) below the intake grill.**

**Required Minimum Space for Installation and Service**

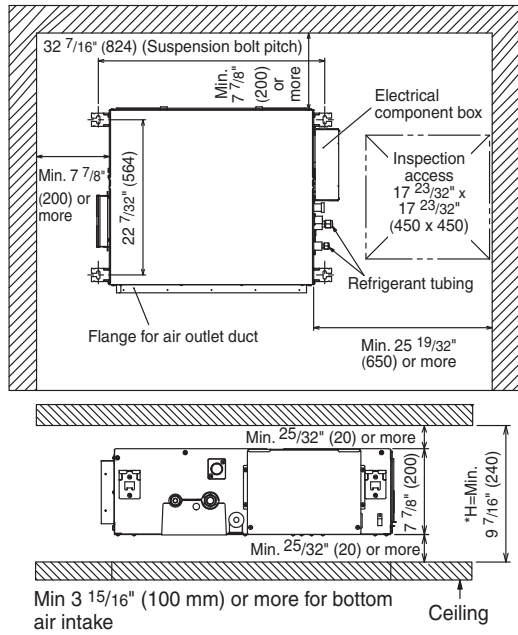

- H dimension means the minimum height of the unit installation space.
- Select H dimension such that a downward slope of at least 1/100 is ensured. Refer to 11.1.4 "Connecting the drain piping"

**Dimension of the Indoor Unit**

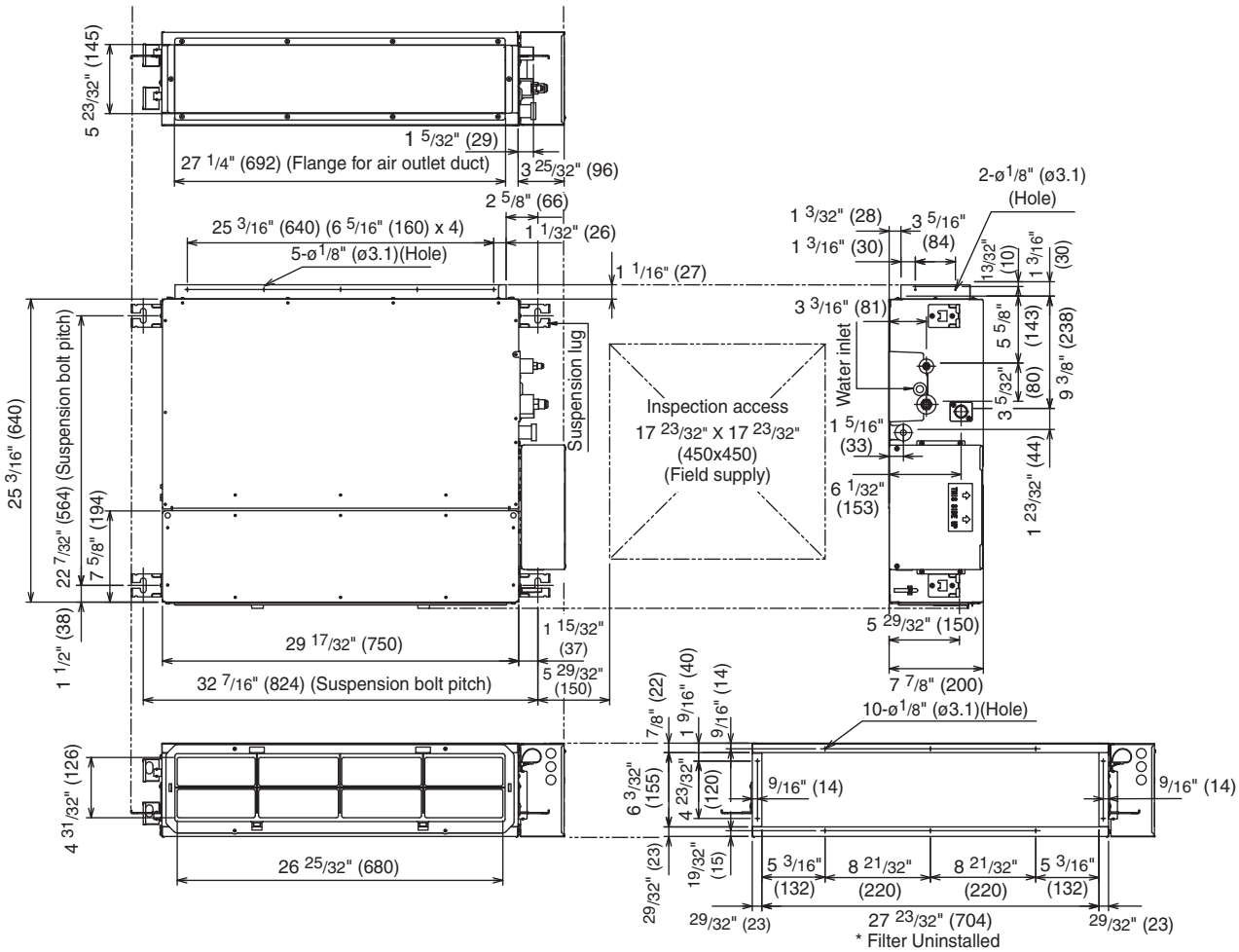

### In Case of Bottom Intake

- 1 Remove the frame filter assy as shown in diagram ①
- 2 Remove cover plate as shown in diagram ①
- 3 Fix frame filter assy as shown in diagram ②
- 4 Fix cover plate as shown in diagram ② with the dummy hole downward.

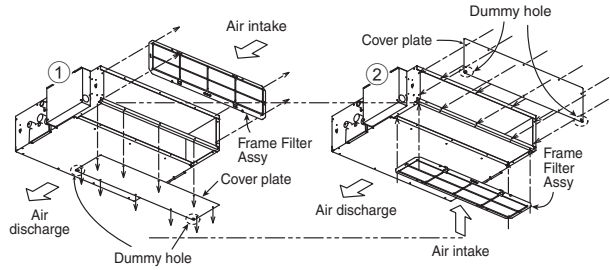

### Fixing Frame Filter Assy

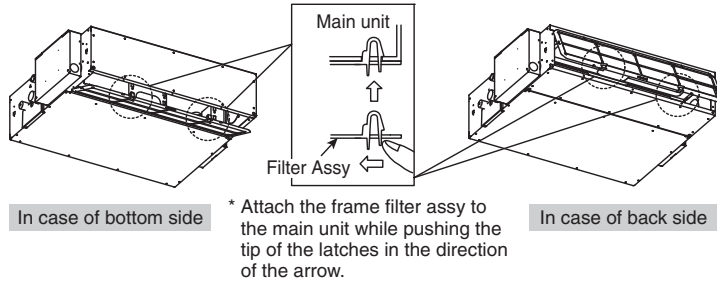

### Ceiling Opening

- Install inspection opening 17 23/32" x 17 23/32" (450 mm x 450 mm) on the control box side where maintenance and inspection of the control box and drain pump are easy. Install another inspection opening 31 1/2" x 27 9/16" (800 mm x 700 mm) also at the lower part of the unit.

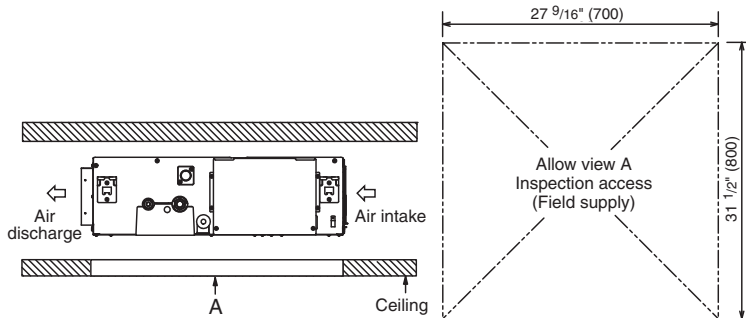

### Securing the Hanging Bolts

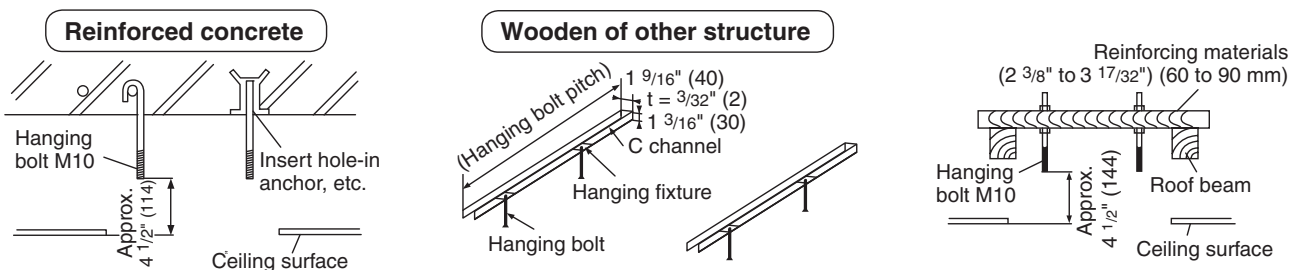

- Secure the hanging bolts (M10, locally purchased) firmly in a manner capable of supporting the unit weight.
- Consult your construction or interior contractor for details on finishing the ceiling opening.

### Installing an Intake and Discharge Duct Type

- Ensure the range of unit external static pressure is not exceeded. Refer technical manual for the range of external static pressure setting.
- Connect the duct as shown.
- When attaching duct to the intake side, remove the product filter frame assy and replace with locally purchase intake-side flange by using 10 -  $\text{Ø } 1/8''$  ( $\text{Ø } 3.1$ )(hole) screws.
- Wrap the flange and duct connection area with aluminium tape or similar to prevent air leak.

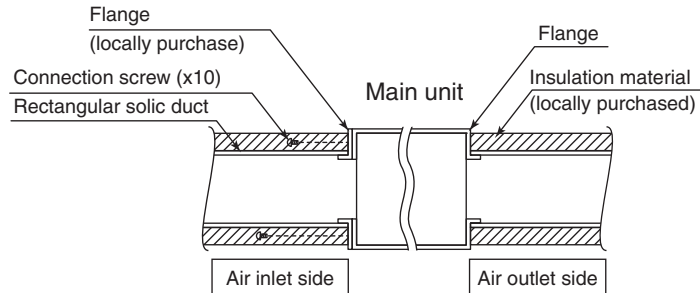

### CAUTION

When attaching a duct to the intake-side, be sure to attach an air filter inside the air passage on the intake-side. (Use an air filter with dust collecting efficiency at least 50% in a gravimetric technique.)

### Installation into the Ceiling

- Attach the nuts and washers to the hanging bolts, then lift up and hook the main unit onto the hanging fixtures.
- Check if the unit is leveled using a level or a vinyl hose filled partially with water.

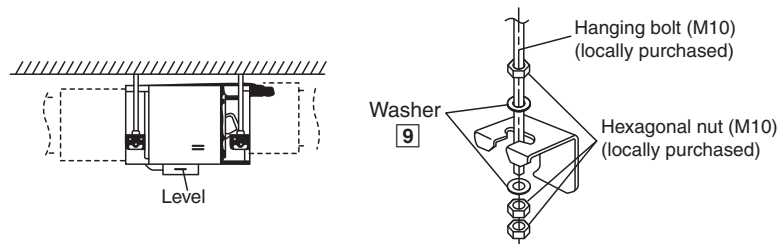

## Mounting Remote Controller Receiver



Install the remote controller receiver cable at least 1 31/32" (50 mm) away from electric wires of other appliances to avoid miss-operation (electromagnetic noise).

### 1 Remove the bottom case.

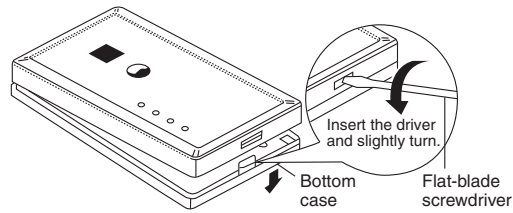

### 2 Mount to the wall.

#### Attention

##### Mounting the bottom case

- Tighten the screws securely until the screw heads touch the bottom case. (Otherwise, loose screw heads may hit the PCB and cause malfunction when mounting the top case.)
- Do not over-tighten the screws. (The bottom case may be deformed, resulting in fall of the unit.)

##### Connecting the remote control wiring

- Arrange the wires as shown in the illustration for ② as in diagram below, avoiding unnecessary wires being stored in the case. (Caught wires may destroy the PCB.)
- Avoid wires touching parts on the PCB. (Caught wires may destroy the PCB.)

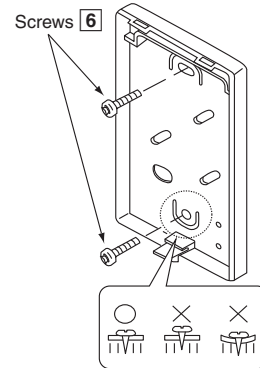

#### EXPOSED TYPE

**Preparation:** Make 2 holes for screws using a driver.

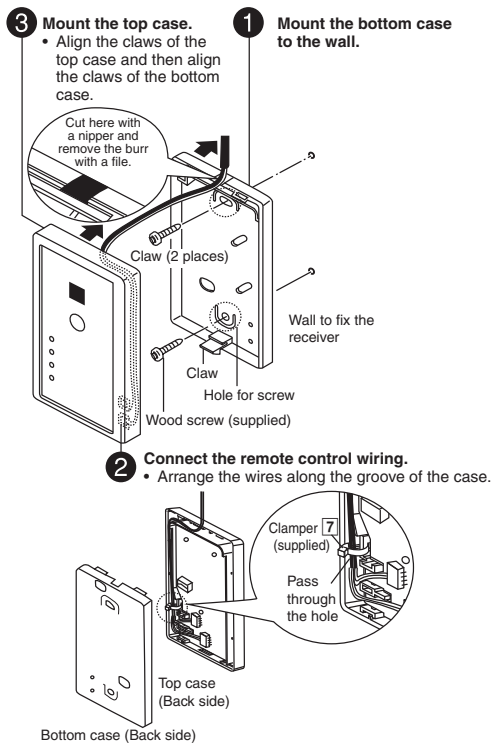

#### EMBEDDED TYPE

**Preparation:** Make 2 holes for screws using a driver.

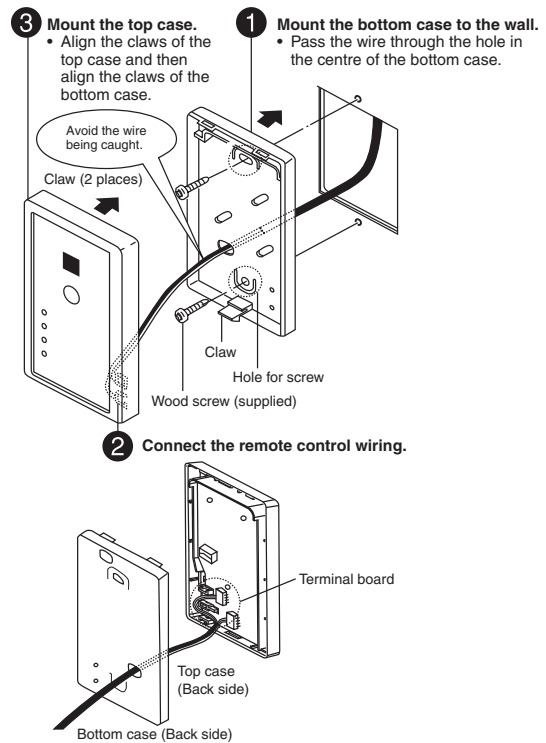

- Connect the indoor unit and the remote control receiver [5]. (Refer to the illustration.)
- Fix the green wire from receiver cable [8] to the grounding location provided inside control board.

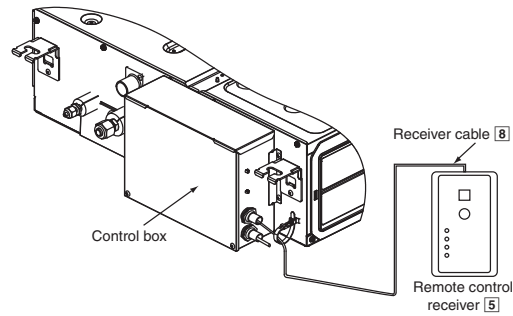

### 11.1.4 Connecting the Drain Piping

- Lay the drain piping so as to ensure drainage.
- Use a locally purchased VP20 general rigid PVC pipe (outer diameter  $\varnothing 1 \frac{1}{32}$ " ( $\varnothing 26$ )) for the drain piping **and firmly connect the indoor unit and the drain piping using supplied hose band to ensure that no leakage occurs.**
- Drain piping located indoor should always be insulated by wrapping with locally purchased insulation (foamed polyethylene with a thickness of  $\frac{13}{32}$ " (10 mm) or more).
- The drain piping should have a downward gradient (1/100 or more) and should be secured by using pipe hanging equipment to avoid creating hills or traps partway.
- Should there be any obstacle preventing the drain piping from being extended smoothly, the drain piping can be raised outside of the main unit as shown in the illustration below.

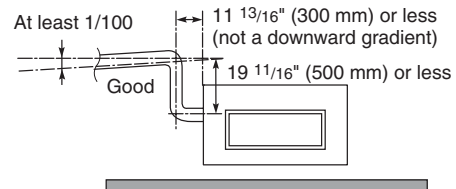
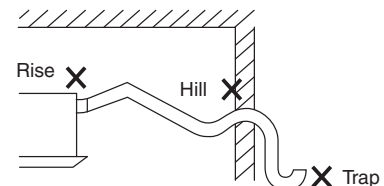
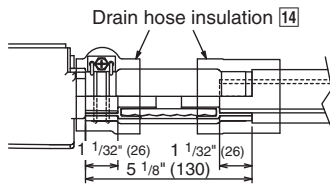
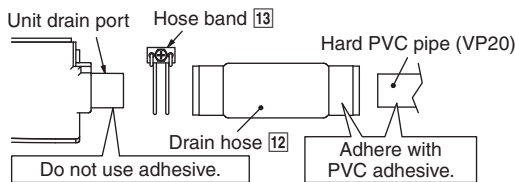

#### CAUTION

- Strictly do not install and extend the drain piping from the main unit drain water outlet horizontally or upward or raised it  $19 \frac{11}{16}$ " (500 mm) or more. Doing so may result in poor drainage or drain motor failure.
- Do not use drain hose bent at 90° angle. (The maximum permissible bend is 45°.)

### 11.1.5 Insulating the Refrigerant Piping



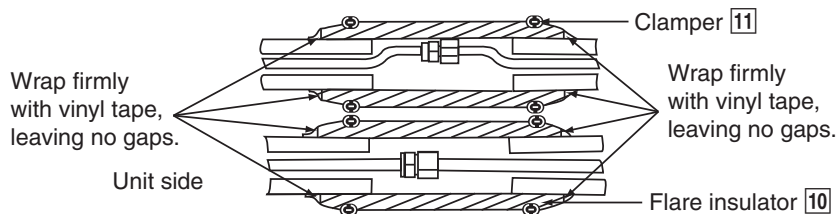



- After the piping is connected, insulate. (Refer to the illustration)





## 11.1.6 Connect the Cable to the Indoor Unit

- Remove control box cover.
- Remove the plugs.
- Fix the conduit connections to the knockout holes together with lock nuts, then secure them against the control box side panel.
- Receiver cable wires **8** must pass through the upper conduit hole. Make sure the receiver cable is inserted from inside of the control box. Connect receiver cable connector to control box wire connector and fix it to the power supply cord holder as shown in the diagram. Insert firmly the connector of receiver cable **8** to connector at control box of indoor unit.
- Connection cable between indoor unit and outdoor unit should be UL listed or CSA approved 4 conductor wires minimum AWG16 in accordance with local electric codes.
  - Ensure that the terminal numbers on the indoor unit are connected to the same terminal numbers on the outdoor unit by the right coloured wires as shown in the diagram.
  - Earth lead wire should be longer than the other lead wires as shown in the diagram for electrical safety purpose in case the cord slips out from the anchorage.
  - Secure the cable onto the control board with the holder (clamber).

Terminals on the indoor unit	1	2	3	
Colour of wires				
Terminals on the outdoor unit	1	2	3	

### CAUTION

When the wall is hollow, please be sure to use the sleeve for tube ass'y to prevent dangers caused by mice biting the connection cable.

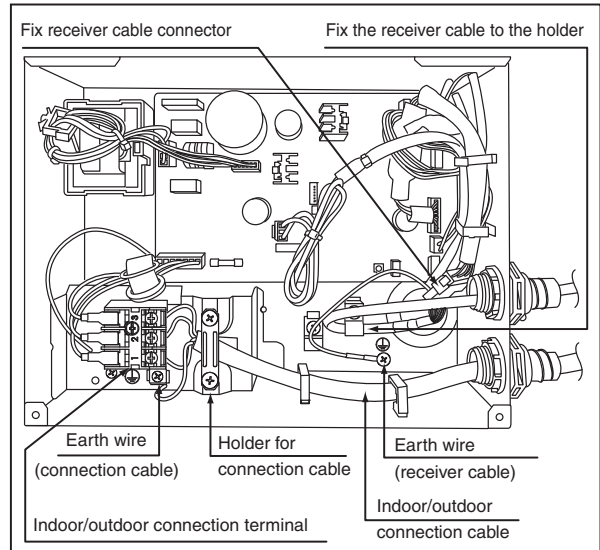
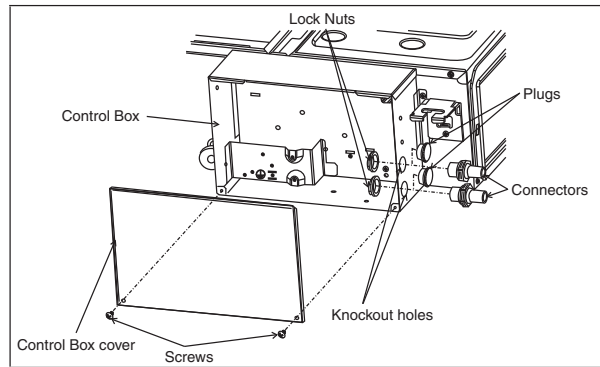

### WARNING

 This equipment must be properly earthed.

- Ensure the colour of wires of outdoor unit and the terminal Nos. are the same to the indoor's respectively.
- Earth wire shall be Yellow/Green (Y/G) in colour and longer than other AC wires for safety reason.

### 11.1.6.1 Wire Stripping and Connecting Requirement

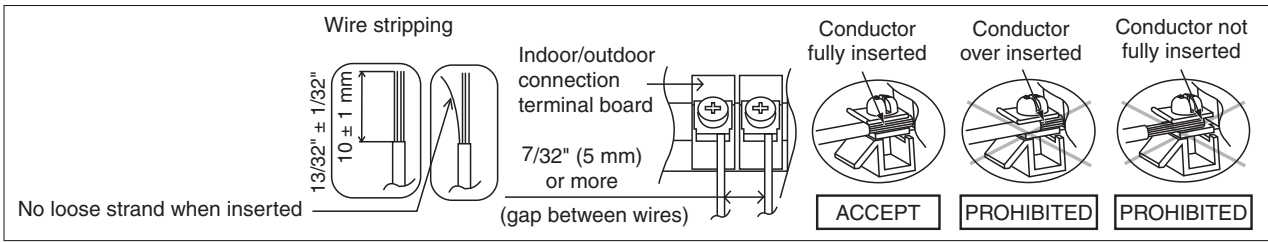

Do not joint wires

**WARNING**

**RISK OF FIRE**  
JOINING OF WIRES MAY CAUSE OVERHEATING AND FIRE.

- ❗ Use complete wire without joining.
- ❗ Use approved socket and plug with earth pin.
- ❗ Wire connection in this area must follow to national wiring rules.

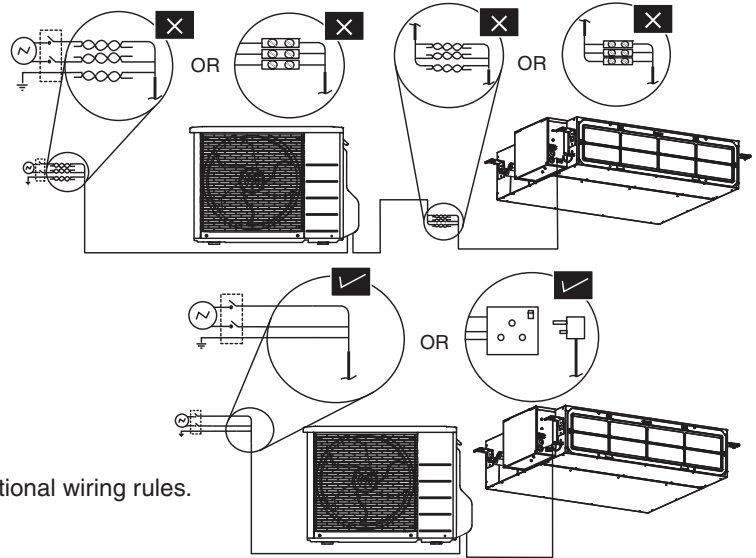

#### Switching the High State Switch (SW2)

- To increase the air volume, open the control box and on the control board, switch the FAN switch (SW2) to “HI”.
- See the diagram for “Connecting the Indoor/Outdoor Connection Cable”.

#### Note: Enabling Long-range Remote Control

- To maintain EMC emission limits, cabling interconnecting the HA terminal and subsequent opto-coupler, must be no more than 6.2 ft (1.9 m) length.
- Loop four turns of this cable through a suitable small EMC ferrite toroid, and protect with a short length of large diameter heat-shrink tube.
- There is no similar length limit for cable following on from the opto-coupler isolation.

#### CHECK THE DRAINAGE

##### Check after connecting the power supply.

- Pour approximately 600 cc of water into the drain pan of the main unit using a squeeze bottle, etc.
- Press the drain test run switch on the control board in the control box to start the drain motor and check whether the water drains normally. (The drain motor operates for approximately 5 minutes and then stops automatically.) (See the diagram for “Connecting the Indoor/Outdoor Connection Cable”.)

