

Panasonic®

Operating Instructions CD Stereo System



The illustrations show SC-AK340.

Model No. **SC-AK340**
SC-AK240



Table of contents

IMPORTANT SAFETY INSTRUCTIONS ..3
Placement of speakers.....3
Getting started.....4
Overview of controls.....6
Discs.....7
Cassette tape – Play and record.....11
Radio.....13
Microphone mixing.....14
Timer.....15
Sound adjustment.....16
External unit.....17
Maintenance.....17
When moving the unit.....17
Troubleshooting guide.....18
Specifications.....19

Before connecting, operating or adjusting this product, please read the instructions completely. Please keep this manual for future reference.

Operations in these instructions are described mainly using remote control, but you can do the operations on the main unit if the controls are the same.

Unless otherwise indicated, illustrations in these operating instructions are of SC-AK340.

Your unit may not look exactly the same as illustrated.

SUPPLIED ACCESSORIES

Please check and identify the supplied accessories.

1 x AC power supply cord

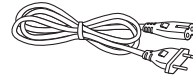

2 x Remote control batteries



1 x Power plug adaptor

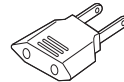

1 x FM indoor antenna



1 x AM loop antenna



1 x Remote Control

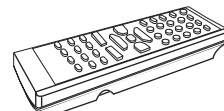

(N2QAHB000065)

Dear customer

Thank you for purchasing this product.
For optimum performance and safety, please read these instructions carefully.

These operating instructions are applicable to the following systems.

- AK340** : indicates features applicable to SC-AK340 only.
- AK240** : SC-AK240 only.

System	SC-AK340	SC-AK240
Main unit	SA-AK340	SA-AK240
Speakers	SB-AK340	SB-AK240



CAUTION	— CLASS 1M INVISIBLE LASER RADIATION WHEN OPEN. DO NOT VIEW DIRECTLY WITH OPTICAL INSTRUMENTS. IEC20825-1:40/Class 1M
WARNING	— KLASS 1M OSYNYLIJ LASERSTRÄLNING NÄR DENNA DEL ÄR ÖPPNAD. BETRÄKTA EJ STRÄLLEN DIREKT MED OPTISKA INSTRUMENTEN.
FORSIGTIG	— OSYNYLIJ LASERSTRÄLNING KLASSE 1M, NÄR LÅGET ÄR ÖBENT. UNDVLÅT SE LÅSET MED OPTISKE INSTRUMENTER.
VARO!	— AVATTAESSA OLET ALTIMA LUOKAN 1M NÄKYMÄTÖNÄ LASERSÄTELYÄ. ÄLÄ KATSO OPTISELLA LAITTEELLA SUORAAN SÄTEESEEN.
VORSICHT	— UNSICHTBARE LASERSTRÄHLUNG KLASSE 1M, WIENN ABDECKUNG GEÖFFNET. NICHT DIREKT MIT OPTISCHEN INSTRUMENTEN BETRACHTEN.
ATTENTION	— RAYONNEMENT LASER INVISIBLE, CLASSE 1M, EN CAS D'OUVERTURE. NE PAS REGARDER DIRECTEMENT À L'ANDE D'INSTRUMENTS D'OPTIQUE.
注意	— ここを開くと不可視レーザー光が出ます。ビームを見たり、触れたりしないでください。
注意	— 打开时有不可见激光辐射。避免光照射。 GB7241.1-2001/GB 类 RQLXS0071

Inside of product

CAUTION!
Change the voltage setting to suit the AC voltage in your area. See page 4.
Note that the unit will be seriously damaged or fail to operate correctly if this setting is not made correctly.

THIS UNIT IS INTENDED FOR USE IN TROPICAL CLIMATES.

The socket outlet shall be installed near the equipment and easily accessible or the mains plug or an appliance coupler shall remain readily operable.

This product may receive radio interference caused by mobile telephones during use. If such interference is apparent, please increase separation between the product and the mobile telephone.

CAUTION!
THIS PRODUCT UTILIZES A LASER.
USE OF CONTROLS OR ADJUSTMENTS OR PERFORMANCE OF PROCEDURES OTHER THAN THOSE SPECIFIED HEREIN MAY RESULT IN HAZARDOUS RADIATION EXPOSURE.
DO NOT OPEN COVERS AND DO NOT REPAIR YOURSELF. REFER SERVICING TO QUALIFIED PERSONNEL.

WARNING:
TO REDUCE THE RISK OF FIRE, ELECTRIC SHOCK OR PRODUCT DAMAGE, DO NOT EXPOSE THIS APPARATUS TO RAIN, MOISTURE, DRIPPING OR SPLASHING AND THAT NO OBJECTS FILLED WITH LIQUIDS, SUCH AS VASES, SHALL BE PLACED ON THE APPARATUS.

- CAUTION!**
- DO NOT INSTALL OR PLACE THIS UNIT IN A BOOKCASE, BUILT-IN CABINET OR IN ANOTHER CONFINED SPACE. ENSURE THE UNIT IS WELL VENTILATED. TO PREVENT RISK OF ELECTRIC SHOCK OR FIRE HAZARD DUE TO OVERHEATING, ENSURE THAT CURTAINS AND ANY OTHER MATERIALS DO NOT OBSTRUCT THE VENTILATION VENTS.
 - DO NOT OBSTRUCT THE UNIT'S VENTILATION OPENINGS WITH NEWSPAPERS, TABLECLOTHS, CURTAINS, AND SIMILAR ITEMS.
 - DO NOT PLACE SOURCES OF NAKED FLAMES, SUCH AS LIGHTED CANDLES, ON THE UNIT.
 - DISPOSE OF BATTERIES IN AN ENVIRONMENTALLY FRIENDLY MANNER.

– If you see this symbol –

Information on Disposal in other Countries outside the European Union

This symbol is only valid in the European Union.
If you wish to discard this product, please contact your local authorities or dealer and ask for the correct method of disposal.

IMPORTANT SAFETY INSTRUCTIONS

Read these operating instructions carefully before using the unit. Follow the safety instructions on the unit and the applicable safety instructions listed below. Keep these operating instructions handy for future reference.

- 1) Read these instructions.
- 2) Keep these instructions.
- 3) Heed all warnings.
- 4) Follow all instructions.
- 5) Do not use this apparatus near water.
- 6) Clean only with dry cloth.
- 7) Do not block any ventilation openings. Install in accordance with the manufacturer's instructions.
- 8) Do not install near any heat sources such as radiators, heat registers, stoves, or other apparatus (including amplifiers) that produce heat.
- 9) Protect the power cord from being walked on or pinched particularly at plugs, convenience receptacles, and the point where they exit from the apparatus.
- 10) Only use attachments/accessories specified by the manufacturer.
- 11) Use only with the cart, stand, tripod, bracket, or table specified by the manufacturer, or sold with the apparatus. When a cart is used, use caution when moving the cart/apparatus combination to avoid injury from tip-over.
- 12) Unplug this apparatus during lightning storms or when unused for long periods of time.
- 13) Refer all servicing to qualified service personnel. Servicing is required when the apparatus has been damaged in any way, such as power-supply cord or plug is damaged, liquid has been spilled or objects have fallen into the apparatus, the apparatus has been exposed to rain or moisture, does not operate normally, or has been dropped.



Placement of speakers

AK340

Place the front speakers so that the tweeter is on the inside.

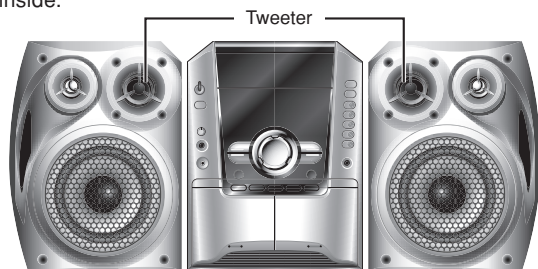

AK240

Speakers are designed identically so that no left or right channel orientation is necessary.



You cannot take the front net off the speakers.

Use only the supplied speakers.

The combination of the main unit and speakers provide the best sound. Using other speakers can damage the unit and sound quality will be negatively affected.

Note:

- Keep your speakers at least 10mm away from the system for proper ventilation.
- These speakers do not have magnetic shielding. Do not place them near televisions, personal computers or other devices easily influenced by magnetism.
- You can damage your speakers and shorten their useful life if you play sound at high levels over extended periods.
- Reduce the volume in the following cases to avoid damage.
 - When playing distorted sound.
 - When adjusting the sound quality.

Caution

- **Use the speakers only with the recommended system. Failure to do so can damage the amplifier and speakers, and can cause fire. Consult a qualified service person if damage occurs or if a sudden change in performance is apparent.**
- **Do not attach these speakers to walls or ceilings.**

Getting started

Step 1 - Making the connections

Connect the AC power supply cord only after all other connections have been made.

5 Connect the AC power supply cord.

Insertion of connector

Even when the connector is perfectly inserted, depending on the type of inlet used, the front part of the connector may jut out as shown in the drawing. However there is no problem using the unit.

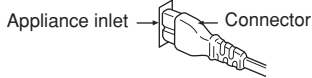

If the power plug does not fit your socket, use the power plug adaptor (included).

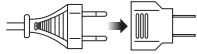

For your reference

To save power when the unit is not to be used for a long time, unplug it from the household AC outlet. You will need to reset some memory items after plugging in the unit.

Note:

The included AC power supply cord is for use with this unit only. Do not use it with other equipment.

1 Connect the AM loop antenna.

Stand the antenna up on its base.

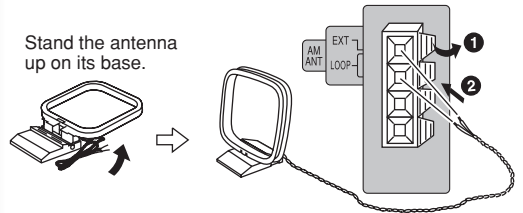

2 Connect the FM indoor antenna.

Tape the antenna where reception is best.

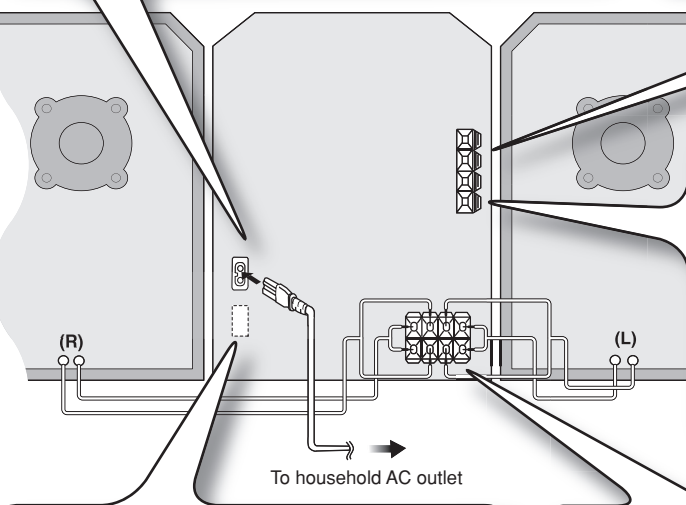
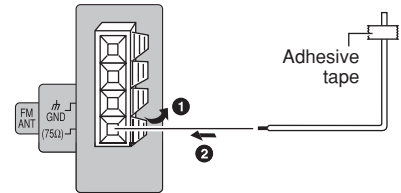

4 Voltage selector.

Use a flat-head screwdriver to set the voltage selector on the rear panel to the appropriate position for the area in which this system is used.

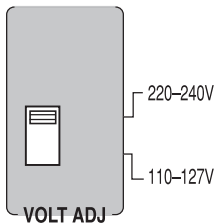

3 Connect the speaker cords.

AK340

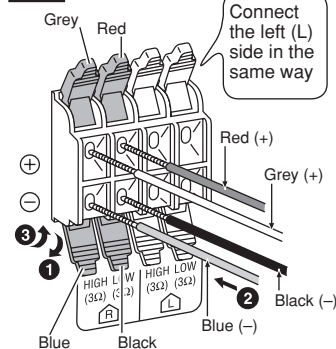

AK240

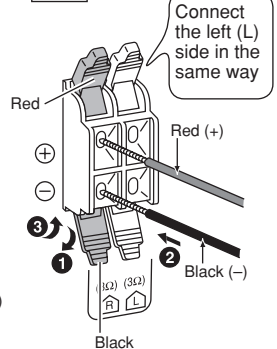

Optional antenna connections

Use outdoor antenna if radio reception is poor.

Note:

Disconnect the outdoor antenna when the unit is not in use. Do not use the outdoor antenna during a lightning storm.

FM outdoor antenna

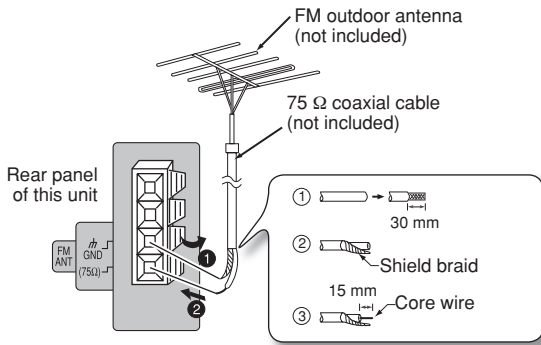

- Disconnect the FM indoor antenna.
- The antenna should be installed by a competent technician.

AM outdoor antenna

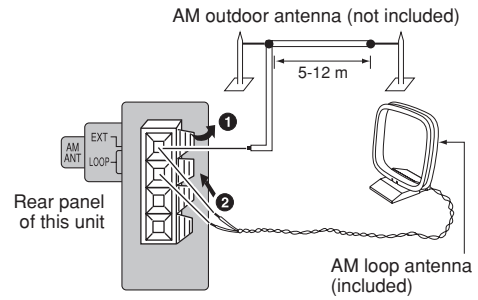

- Run a piece of vinyl wire horizontally across a window or other convenient location.
- Leave the loop antenna connected.

Step 2 - Inserting batteries into the remote control

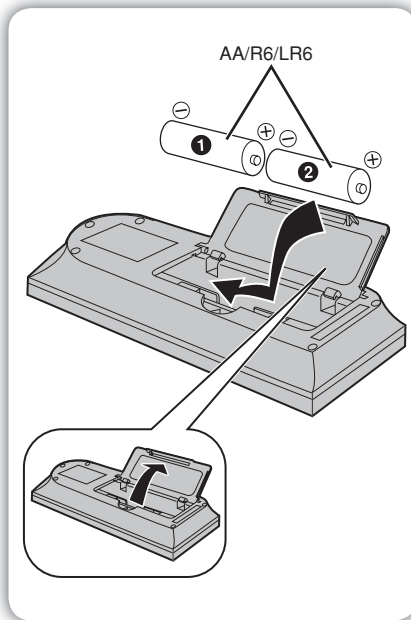

■ Batteries

- Insert so the poles (+ and -) match those in the remote control.
- Remove if the remote control is not going to be used for a long period of time. Store in a cool, dark place.
- Replace if the unit does not respond to the remote control even when held close to the front panel.
- Do not use rechargeable type batteries.
- Mishandling of batteries in the remote control can cause electrolyte leakage, which may cause a fire.
- If electrolyte leaks from the batteries, consult your dealer. Wash thoroughly with water if electrolyte comes in contact with any part of your body.

Do not:

- mix old and new batteries.
- use different types at the same time.
- heat or expose to flame.
- take apart or short circuit.
- attempt to recharge alkaline or manganese batteries.
- use batteries if the covering has been peeled off.
- put heavy objects on the remote control.
- spill liquids onto the remote control.

■ Use

Aim at the remote control sensor, avoiding obstacles, at a maximum range of 7 m directly in front of the unit. Refer to page 6 for the remote control sensor position.

Step 3 - DEMO function



When the unit is first plugged in, a demonstration of its functions may be shown on the display.

If the demo setting is off, you can show a demonstration by selecting "DEMO ON".

Press and hold [DISPLAY, -DEMO].

The display changes each time the button is held down.

NO DEMO (off) ↔ DEMO ON (on)

While in standby mode, select "NO DEMO" to reduce power consumption.

Note:

DEMO function cannot be turned on when Dimmer is on.

Overview of controls

Main unit

Refer to the numbers in parentheses for page reference.

AC supply indicator [AC IN]
This indicator lights when the unit is connected to the AC power supply.

1 Standby/on switch [ON/OFF, POWER] (10, 18)
Press to switch the unit from on to standby mode or vice versa. In standby mode, the unit is still consuming a small amount of power.

Multiple discs change (8)

Display panel

2 Volume control

Microphone volume control (14)

3 Tuner/Band selection (13)

Microphone jack (14)

Music port jack (17)

4 Music port selection (17)

Deck 1 open (11)

Disc skip/search, tape fast-forward/rewind, tune/preset channel selection, time adjustment (11)

Record (12, 17)

Display, demonstration (5)

5 H.BASS selection (16)

Deck 1 cassette holder (11)

Remote control signal sensor

Disc trays

Disc tray open/close (7)

Single disc change (8)

Disc direct play (8)

6 Disc play/pause (7)

Headphone jack (PHONES)

Avoid listening for prolonged periods of time to prevent hearing damage.
Plug type: 3.5 mm stereo (not included)

7 Tape play (11)

Deck 2 open (11)

Stop (11)

Deck selection (11)

Deck 2 cassette holder (11)

AK340

To select the desired display during play mode.

Each time you press the button: Normal → Reflection → (off)

DISPLAY-12345

Remote control

Buttons such as **1** function the same as the controls on the main unit.

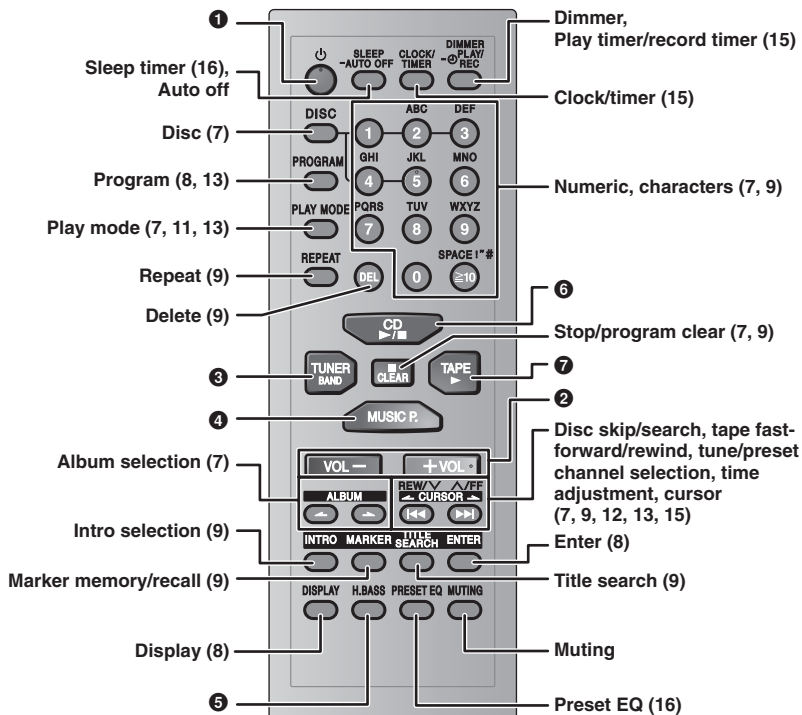

This auto off function allows you to turn off the unit in **disc or tape** mode only after left unused for 10 minutes.

- Press and hold [-AUTO OFF] to activate the function.
- Press and hold [-AUTO OFF] again to cancel.
- The setting is maintained even if the unit is turned off.



To dim the display panel.



To mute the sound.

- Press the button to activate.
- Press again to cancel.

Discs

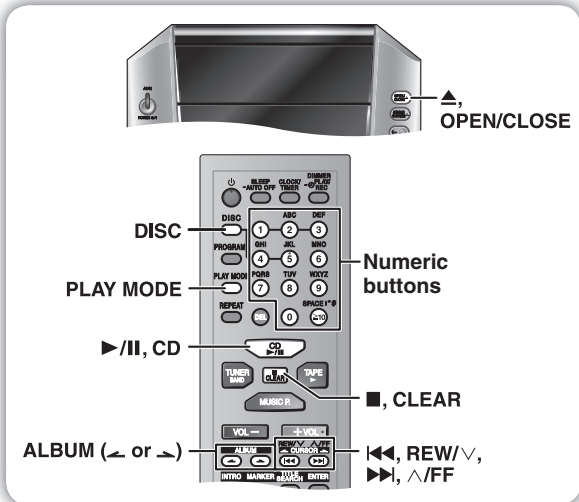

Basic play

- 1 Press [▲, OPEN/CLOSE] on the main unit to open the tray.
The unit turns on, load a disc in the current tray with the label facing up.
Press [▲, OPEN/CLOSE] to close the tray.
- 2 Press [►/II, CD] to start play.
You can also press [DISC] and then [1] ~ [5] to select and play the other loaded discs.



To	Action
stop play	Press [■, CLEAR] during play. MP3 WMA Display when in the stop mode: Example: "MP3" indicates the disc contains MP3 files.
pause play	Press [►/II, CD] during play. Press again to resume play.

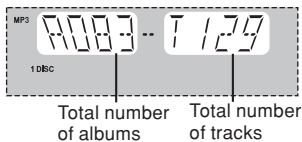

skip album	MP3 WMA Press [ALBUM (◀ or ▶)] to select the desired album during play or when in stop mode. Display when selecting in stop mode (example):
------------	---

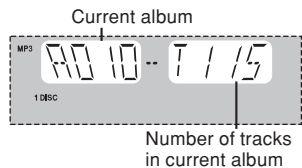

- This function does not work during 1-DISC RANDOM and ALL-DISC RANDOM mode. It is applicable only during program stop mode.

skip tracks Press [◀◀, REW/∇] or [▶▶, ∨/FF].
• During random play (⇒ see below, "Play Mode function"), you cannot skip to tracks which have been played.

MP3 WMA

During 1-ALBUM and 1-ALBUM RANDOM mode, track skipping can only be done within the current album.

search through tracks CD
Press and hold [◀◀, REW/∇] or [▶▶, ∨/FF] during play or pause to search.
• During program play (⇒ page 8), or random play (⇒ see below, "Play Mode function"), you can search only within the track.

Play Mode function

CD MP3 WMA

You can listen to specific discs and tracks.

Preparation

Select and play your desired disc.

Press [PLAY MODE] to select the desired mode.

Mode	To play
1-DISC 1 DISC	one selected disc.
1-DISC RANDOM 1 DISC RND	one selected disc randomly.
ALL-DISC ALL DISC	all loaded discs in succession from the selected disc to the final disc. Example: 4→5→1→2→3.
ALL-DISC RANDOM ALL DISC RND	all loaded discs randomly.
1-SONG 1-SONG	one selected track on the selected disc.
CD	Press the numeric buttons to select the track in the current disc. Play starts from the selected track.
MP3 WMA	Press [ALBUM (◀ or ▶)] to select the album. Press the numeric buttons to select the track in the current album. Play starts from the selected track.
1-ALBUM 1-ALBUM MP3 WMA	one selected album on the selected disc. Press [ALBUM (◀ or ▶)] to select the album.
1-ALBUM RANDOM 1-ALBUM RND MP3 WMA	all tracks in one selected album randomly. Press [ALBUM (◀ or ▶)] to select the album.

When playback ends

The current play mode will be retained in memory until it is changed even if the unit is turned off.

Note:

You cannot use program mode together with "Play Mode function".

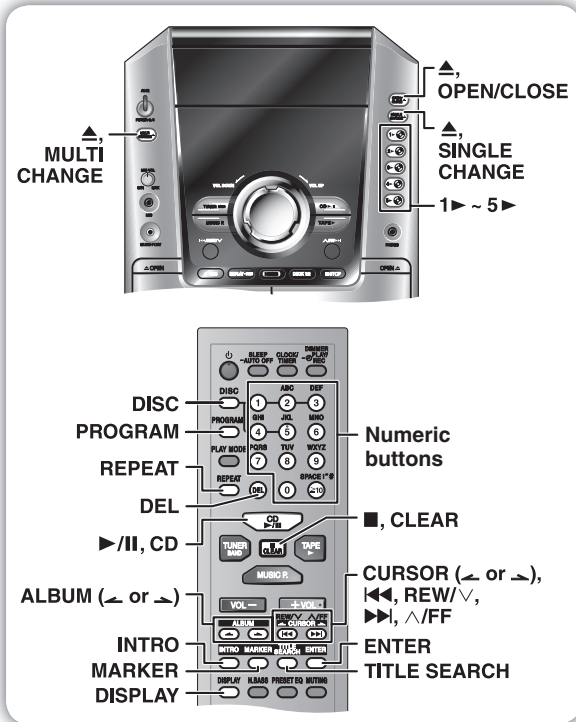

Changing multiple discs (MULTI CHANGE)

By main unit only

- 1 Press [▲, MULTI CHANGE] to open the trays.
- 2 Press the button repeatedly to check and change multiple discs.

Note:

- The tray with a disc being played will not open.
- If the player is stopped, all trays will open. To close the remaining trays simultaneously, press [▲, OPEN/CLOSE].

Changing a single disc (SINGLE CHANGE)

By main unit only

While one disc is playing, you can change the discs in other trays.

- 1 Press [▲, SINGLE CHANGE].
- 2 Press [1 ▶ ~ 5 ▶] to select the desired tray.
- 3 Change the disc.
- 4 Press [▲, SINGLE CHANGE] again to close the tray.

Checking the track information

CD MP3 WMA

You can select a desired disc display mode.

AK340 AK240

Press [DISPLAY] during play or pause.

AK240

Press [DISPLAY, -DEMO] on the main unit during play or pause.

CD

Elapsed play time ↔ Remaining play time

MP3 WMA

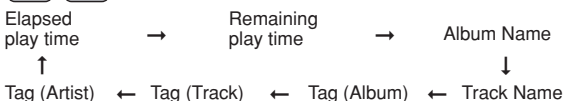

Note:

CD

- When track number 25 or greater is playing, remaining play time display shows “-:-”.

MP3 WMA

- When a title is longer than 9 characters, it will scroll across the display. The scrolling will start after every 3 seconds.
- “NO TAG” is displayed if titles with tags have not been entered.
- Maximum number of displayable characters: approximately 32
- This unit can display album, track and artist name with WMA tags and MP3 ID3 tags (version 1.0 and 1.1).
- Titles containing text data that the unit does not support cannot be displayed.
- ID3 is a tag embedded in MP3 track to provide information about the track.
- Titles entered with 2-byte code cannot be displayed correctly on this unit.

Advanced play

Program play

CD MP3 WMA

This function allows you to program up to 24 tracks.

CD

- 1 Press [▶/II, CD] and then [■, CLEAR].
- 2 Press [PROGRAM].
“PGM” appears.
- 3 Press [DISC] and then [1] ~ [5] to select the disc.
- 4 Press the numeric buttons to select your desired track.
Repeat steps 3 to 4 to program other tracks.
- 5 Press [▶/II, CD] to start play.

MP3 WMA

- 1 Press [DISC] and then [1] ~ [5] to select the disc.
- 2 Press [■, CLEAR].
- 3 Press [PROGRAM].
- 4 Press [ALBUM (← or →)] to select your desired album.
To select an album directly, press the numeric buttons after pressing [ALBUM (← or →)].
- 5 Press [◀◀, REW/√] or [▶▶, √/FF] to select the track.
To select a track directly, press the numeric buttons after pressing [◀◀, REW/√] or [▶▶, √/FF].
- 6 Press [ENTER].
Repeat steps 4 to 6 to program other tracks.
- 7 Press [▶/II, CD] to start play.

For two-digit track, press [≥10] once then the two digits.
For three-digit track, press [≥10] twice then the three digits.

To	Action
cancel program mode	Press [PROGRAM] in the stop mode.
replay the program	Press [PROGRAM] then [▶/II, CD] in the stop mode.

To	Action
add to the program	<p>CD</p> <p>Repeat steps 3 to 4 in the stop mode.</p> <p>MP3 WMA</p> <p>Repeat steps 4 to 6 in the stop mode.</p>
check program contents	<p>Press [◀, REW/∨] or [▶, ∨/FF] when "PGM" is displayed in the stop mode.</p> <p>CD</p> <p>The track number, program order and disc number are displayed:</p> <div style="text-align: center;"> <p>Track number Program order</p> </div> <p>MP3 WMA</p> <p>The program order is displayed followed by the album number and track number.</p>
clear the last track	Press [DEL] in the stop mode.
clear all programmed tracks	Press [■ , CLEAR] in the stop mode. "CLEAR ALL" is displayed. Within 5 seconds, press the button again to clear all tracks.

Note:

- You cannot program CD-DA together with MP3 or WMA tracks.
- The program memory is cleared when you change a disc or open the disc tray.
- You cannot program more than one disc for MP3 or WMA.

Repeat play **CD MP3 WMA**

You can repeat program play or other selected play mode.

Press [**REPEAT**].

"**⏮**" is displayed.

To cancel

Press [**REPEAT**] again.

"**⏮**" is cleared.

Note:

You can use repeat mode with "Program play" (➔ page 8) and "Play Mode function" (➔ page 7).

Marking a track **CD MP3 WMA**

Enables you to mark one track for each loaded disc so that you can directly play the track later.

During play, press and hold the [MARKER] until "STORING" blinks on the display to mark your favourite track.

Press [MARKER] during play or stop mode to recall and play a marked track.

Note:

- "NO MARKER" indicates that the marker in the current disc is empty.
- The marker memory is cleared when you open the disc trays except for the current disc which is in play or pause mode.
- This function does not work during any random/program mode.

Advanced function (**MP3 WMA** only)

Album scan

This function allows you to find an album by listening to the first track of all albums in the current disc for 10 seconds each.

- Press [**▶/II**, CD] and then [**■**, CLEAR].
- Press [**INTRO**] to start the intro function.
- While your desired album is playing, press [**▶/II**, CD]. Intro mode is canceled and the playback continues.

INTRO function is canceled after playing the first track in the last album.

To stop during the process, press [**INTRO**] or [**■**, CLEAR].

Note:

This function does not work during any random/program mode.

Album/Track title search

This function enables you to search your desired album or track.

- Press [**▶/II**, CD] and then [**■**, CLEAR].
- For album title search, press [**TITLE SEARCH**] once. For track title search, press [**TITLE SEARCH**] twice.
- Press the numeric buttons repeatedly to select your desired character then press [**CURSOR** ➔] to key in the next character.
 - You can enter up to 8 characters.
 - To edit, press [**CURSOR** (← or ➔)] to revise any characters.
 - To delete, move the cursor over the character and then press [**DEL**].

Numbered buttons	Characters	Numbered buttons	Characters
1	1	6	M N O 6
2	A B C 2	7	P Q R S 7
3	D E F 3	8	T U V 8
4	G H I 4	9	W X Y Z 9
5	J K L 5	0	0
≥10	space ! " # \$ % & ' () * + , - . / : ; = ? _ `		

You can search for "<" or ">" by entering "(" or ")". The special characters will be displayed as below:

Characters	Main unit display	Characters	Main unit display
!	∇	,	/
"	∥	-	--
#	⏮	.	·
\$	⏮	/	/
%	1/1	:	!
&	∇	;	/
'	'	=	--
(∇	?	∇
)	∇	-	-
*	*	`	∥
+	+		

Some characters may not be displayed correctly due to the recording format/software used.

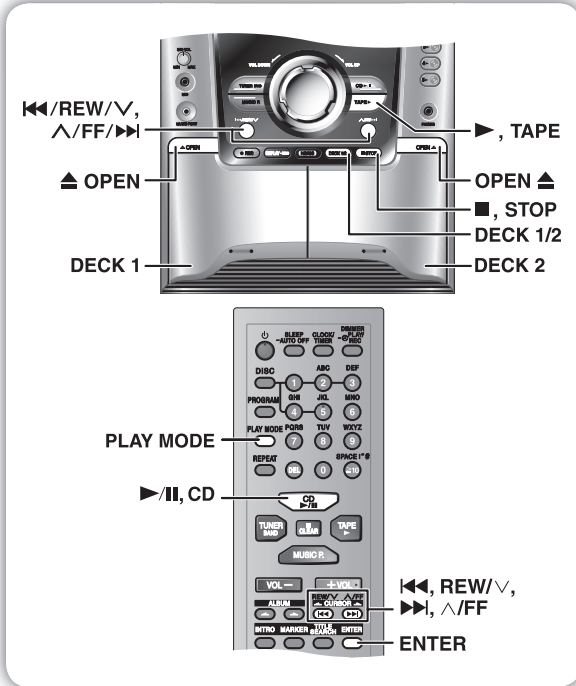

- 4 Press [ENTER].**
 Press [**REW/V**] or [**FF**] to search for previous or next match.

The match title is displayed.

Album title search

Blinks to indicate album title search mode

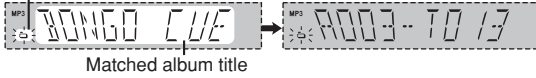

Track title search

Matched track title



- 5 Press [CD].** to start play from the album/track found.

Note:

This function does not work during any random/program mode.

NOTE on CDs

- This unit can access up to 99 tracks.
- Choose disc with this mark.



- This unit can play MP3 or WMA files and CD-DA format audio CD-R/RW that have been finalized.
- It may not be able to play some CD-R/RW due to the condition of the recording.
- Do not use irregularly shaped disc.
- Do not use disc with labels and stickers that are coming off or with adhesive exuding from under labels and stickers.
- Do not attach extra labels or stickers on the disc.
- Do not write anything on the disc.

Using DualDiscs

The "CD" sides of DualDiscs do not meet the CD-DA standard so it may not be possible to play them on this unit.

- Not doing the following will cause damage to the unit.
- Press [POWER] to turn off the unit and remove the power plug only after all the displays have disappeared.



- Always press [**OPEN/CLOSE**] to insert or remove a disc.
- Do not push or pull out the tray by hand as this will cause an accident.

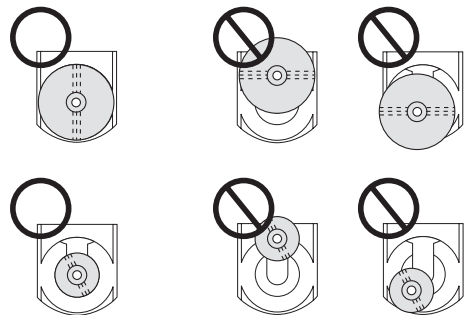

- Place the disc correctly label-up as shown in the diagram.
- Insert one disc into the tray.

Cassette tape – Play and record

The buttons described for “Cassette tape – Play and record” are mainly for the main unit unless indicated otherwise.

NOTE on MP3 or WMA

- Files are treated as tracks and folders are treated as albums.
- This unit can access up to 999 tracks, 255 albums and 20 sessions.
- Disc must conform to ISO9660 level 1 or 2 (except for extended formats).
- To play in a certain order, prefix the folder and file names with 3-digits numbers in the order you want to play them.

MP3

When “NOT MP3/ERROR1” appears on the display, an unsupported MP3 format is being played. The unit will skip that track and play the next one.

WMA

- Noise may occur when playing WMA files.
- This unit cannot play WMA files that are copy protected.

Limitations on MP3 or WMA play

- If you have recorded MP3 or WMA on the same disc as CD-DA, only the format recorded in the first session can be played.
- Some MP3 or WMA may not be played due to the condition of the disc or recording.
- Due to differences and variations of WMA tags, some files may not play or display the tags' information properly.
- Recordings will not necessarily be played in the order you recorded them.

MPEG Layer-3 audio decoding technology licensed from Fraunhofer IIS and Thomson multimedia.

Windows Media, and the Windows logo are trademarks, or registered trademarks of Microsoft Corporation in the United States and/or other countries.

WMA is a compression format developed by Microsoft Corporation. It achieves the same sound quality as MP3 with a file size that is smaller than that of MP3.



Basic play

You can use either DECK 1 or DECK 2 for tape playback.

Use normal position tapes.

High position and metal position tapes can be played, but the unit will not be able to do full justice to the characteristics of these tapes.

1 Press [▶, TAPE].

The unit turns on.

If a cassette was loaded, play starts automatically (One touch play).

2 Press [▲ OPEN] for DECK 1 or [OPEN ▲] for DECK 2 and insert the cassette.

Insert with the side to be played facing towards you and the exposed tape facing down. Close the holder by hand.

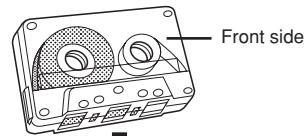

3 Press [▶, TAPE] to start play.

To	Action
stop tape playback	Press [■, STOP].
fast-forward and rewind	Press [◀◀/REW/∨] or [∧/FF/▶▶].
select between loaded decks	Press [DECK 1/2] (remote control : [PLAY MODE]).

Note:

- Tape playback is momentarily interrupted if you open the other deck.
- Tapes exceeding 100 minutes are thin and can break or get caught in the mechanism.
- Tape slack can get caught up in the mechanism and should be wound up before the tape is played.
- Endless tapes can get caught up in the deck's moving parts if used incorrectly.

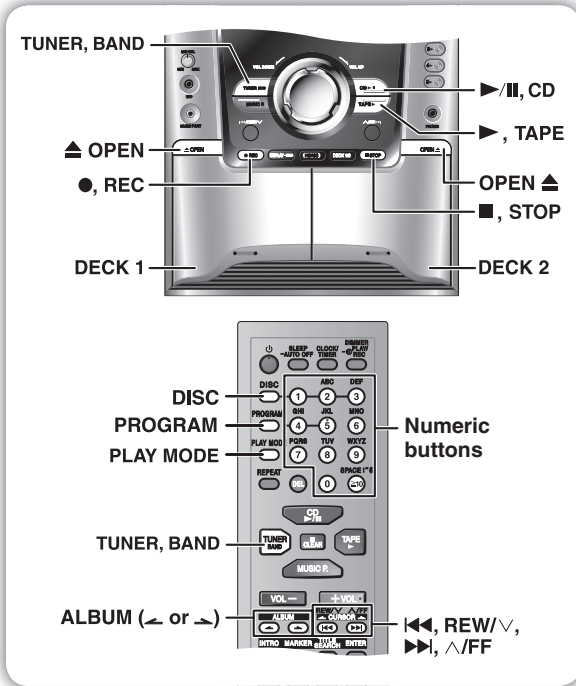

By remote control only

- record specific discs/tracks
- 1) Press [DISC] and then [1] ~ [5] to select the disc. Ensure disc is stopped.
 - 2) Press [PLAY MODE] to select the desired mode (→ page 7).
 - 3) **MP3** **WMA**
For 1-ALBUM mode and 1-SONG mode: Press [ALBUM (← or →)] to select the album.
CD **MP3** **WMA**
For 1-SONG mode: Press [←, REW/√] or [→, ^/FF] to select the track.

Tape-to-tape recording:

- 1 Press [▶, TAPE] and then [■, STOP].
- 2 Press [▲ OPEN] for DECK 1 and insert the cassette to record.

3 Press [●, REC] to start recording.

Other basic operations

To	Action
stop recording	Press [■, STOP].
record on the other side of the tape	Turn the cassette over and press [●, REC].
erase a recorded sound	1) Press [▶, TAPE] and then [■, STOP]. 2) Insert the recorded tape into DECK 2. Ensure there is no tape in DECK 1. 3) Press [●, REC].

Note:

- Changes to volume and sound adjustments do not affect recording.
- You cannot open DECK 1 while recording.
- You cannot fast-forward or rewind one deck while recording with the other.

Recording

Selection of tapes for recording

Use normal position tapes. High position and metal position tapes can be used, but this unit will not be able to record or erase them correctly.

Preparation

Wind up the leader tape so recording can begin immediately.

- 1 Press [OPEN ▲] for DECK 2 and insert the cassette to be recorded. Insert with the side to be recorded facing towards you and the exposed tape facing down.

2 Select the source to be recorded.

Radio recording:

Tune in the station. (→ page 13)

Disc recording:

- 1 Insert the disc(s) you want to record. Press [▶/||, CD] and then [■, STOP].
- 2 Prepare the desired disc recording mode.

To	Action
record programmed tracks	CD Perform steps 2 to 4 in "Program play" (→ page 8).
	MP3 WMA Perform steps 3 to 6 in "Program play" (→ page 8).

Erasure prevention

The illustration shows how to remove the tabs to prevent recording. To record on the tape again, cover as shown.

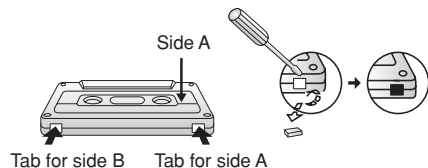

To re-record

Normal cassette



Adhesive tape

Manual tuning

- 1** Press [TUNER, BAND] to select “FM” or “AM”.
- 2** Press [PLAY MODE] to select “MANUAL”.
- 3** Press [◀◀, REW/∨] or [▶▶, ∧/FF] to select the frequency of the required station.
 - “ST” is displayed when a stereo FM broadcast is being received.
 - “TUNED” is displayed when a radio station is tuned.

To tune automatically

Press and hold [◀◀, REW/∨] or [▶▶, ∧/FF] until the frequency starts changing rapidly. The unit begins auto tuning, stopping when it finds a station.

- Auto tuning may be interrupted when there is excessive interference.
- To cancel auto tuning, press [◀◀, REW/∨] or [▶▶, ∧/FF] once again.

To improve FM sound quality

Press and hold [PLAY MODE] to display “MONO”.

To cancel

Press and hold [PLAY MODE] again until “MONO” disappears.

- MONO is also canceled if the frequency is changed.
- Turn off “MONO” for normal listening.

AM allocation setting

By main unit only

This system can also receive AM broadcasts allocated in 10 kHz steps.

To change the step from 9 kHz to 10 kHz

- 1** Press and hold [TUNER, BAND].
After a few seconds the display changes to a flashing display of the current minimum frequency.
- 2** Continue to hold down [TUNER, BAND].
 - When the minimum frequency changes, release the button. To return to the original step, repeat the above steps.
 - After changing the setting, previously preset frequency will be cleared.

Memory preset

Up to 15 stations each can be set in the FM and AM bands.

Preparation

Press [TUNER, BAND] to select “FM” or “AM”.

Automatic presetting

- 1** Tune to the frequency where pre-setting is to begin.
- 2** Press and hold [PROGRAM] to start presetting.

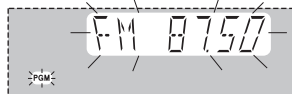

The tuner presets all the stations it can receive into the channels in ascending order. When finished, the last station memorized is tuned in.

Manual presetting

- 1** Press [PLAY MODE] to select “MANUAL”.
- 2** Press [◀◀, REW/∨] or [▶▶, ∧/FF] to tune to the required station.
- 3** Press [PROGRAM].
- 4** Press the numeric buttons to select a channel.
For channels 10 to 15 press [≥10], then the two digits.
The station occupying a channel is erased if another station is preset in that channel.

Selecting a preset station

Press the numeric buttons to select the channel.



OR

- 1** Press [PLAY MODE] to select “PRESET”.
- 2** Press [◀◀, REW/∨] or [▶▶, ∧/FF] to select the channel.

Microphone mixing

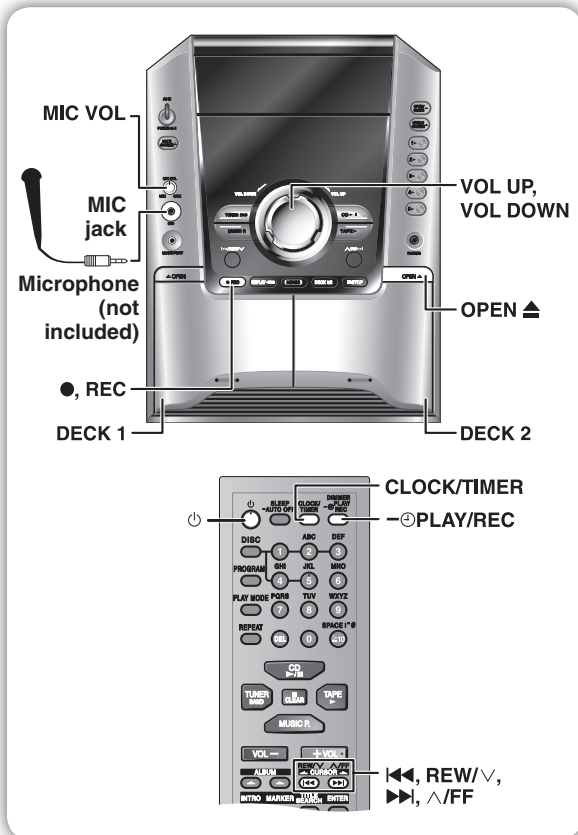

The buttons described for “Microphone mixing” are mainly for the main unit unless indicated otherwise.

Enjoying the microphone mixing

You can enjoy microphone mixing from various music sources (cassette, disc, radio or portable audio equipment).

- 1 Firstly, lower the volume with [MIC VOL], connect the microphone.
Plug type : 3.5 mm monaural
- 2 Start playing the music source.
- 3 Adjust the volume with [VOL UP] or [VOL DOWN] and [MIC VOL] and sing along.

Note:

- If a strange noise (howling) is emitted during use, move the microphone away from the speakers, or turn down the microphone volume.
- When you are not using the microphone, disconnect it from the microphone jack, and turn down the microphone volume level to “MIN”.
- Sound adjustments can be made using microphone mixing but recording will not be affected.

Record microphone mixing

- 1 Press [OPEN ▲] for DECK 2 and insert the cassette to be recorded.
Insert with the side to be recorded facing towards you and the exposed tape facing down.

- 2 Lower the volume with [MIC VOL], then connect the microphone.

- 3 Select the music source:

When singing along with discs Insert the desired disc (⇒ page 7).

When singing along with cassette Insert the desired cassette into DECK 1 (⇒ page 11).
This is applicable only during stop mode.

When singing along with radio Select your desired station (⇒ page 13).

When singing along from a portable audio equipment Connect and prepare the audio equipment (⇒ page 17)

- 4 Press [●, REC] and start microphone mixing.

To record your voice

- 1 Press [OPEN ▲] for DECK 2 and insert the cassette to be recorded.
Ensure that there is no tape in DECK 1.
- 2 Lower the volume with [MIC VOL], then connect the microphone
- 3 Press [●, REC] to start recording.
- 4 Speak through the microphone and adjust the volume with [VOL UP] or [VOL DOWN] and [MIC VOL].

Timer

Setting the clock

This is a 24-hour clock.

- 1 Press [CLOCK/TIMER] to select "CLOCK".
Each time you press the button:

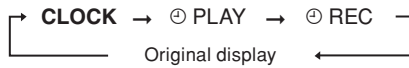

- 2 (Within 8 seconds or so)
Press [◀, REW/∨] or [▶, ∨/FF] to set the time.
- 3 Press [CLOCK/TIMER] to finish setting the time.

Displaying the clock

Press [CLOCK/TIMER] once when the unit is on or in standby mode.

The time is displayed for a few seconds.

Note:

Reset the clock regularly to maintain accuracy.

Using the play or record timer

You can set the timer to come on at a certain time to wake you up (play timer) or to record from the radio or music port source (record timer).

Play timer and record timer cannot be used together.

Turn the unit on and set the clock.

Timer	Action
Play timer	Prepare the music source you want to listen to; cassette (DECK 2 has the priority), disc number (1~5), radio or music port source, and set the volume.
Record timer	Check the cassette's erasure prevention tabs (⇒ page 12), insert the cassette in DECK 2 and tune to the radio station (⇒ page 13) or select the music port source (⇒ page 17).

- 1 Press [CLOCK/TIMER] to select the timer function.
Each time you press the button:



⊕PLAY : to set the play timer

⊕REC : to set the record timer

(Proceed to the next step **within 8 seconds**)

- 2 Press [◀, REW/∨] or [▶, ∨/FF] to set the starting time.

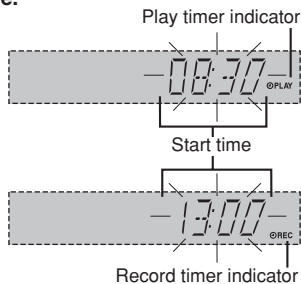

- 3 Press [CLOCK/TIMER] to confirm.

- 4 Repeat steps 2 to 3 to set the finishing time.

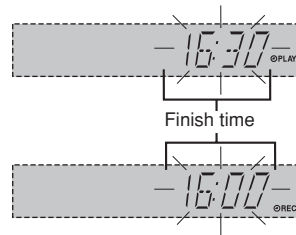

To activate the timer

- 5 Press and hold [-⊕PLAY/REC] to turn on your desired timer.



- 6 Press [⊕] to turn off the unit.
The unit must be off for the timers to operate.

Other basic operations

To	Action
change the settings	Repeat steps 1 to 4 and 6 (⇒ see left and above).
change the source or volume	1) Press and hold [-⊕PLAY/REC] to clear the timer indicator from the display. 2) Make changes to the source or volume. 3) Do steps 5 to 6 (⇒ see above).
check the settings	Press [CLOCK/TIMER] repeatedly to select ⊕PLAY or ⊕REC.
cancel	Press and hold [-⊕PLAY/REC] to clear the timer indicators from the display.

If you use the unit after the timers are set

After using, check that the correct tape/disc are loaded before turning the unit off.

Note:

- The play timer will start at the preset time with volume increasing gradually to preset level.
- The record timer will start 30 seconds before the set time with the volume muted.
- The timer comes on at the set time everyday if the timer is on.
- The unit must be in the standby mode for the timer to function.
- If you turn the unit off and on again while a timer is functioning, the finish time setting will not be activated.
- If MUSIC PORT is selected as the source when the timer comes on, the system turns on and engages MUSIC PORT as the source. If you wish to playback or record from the portable audio equipment, just activate the equipment's play mode and increase the volume. (See the portable audio equipment's instruction manual.)

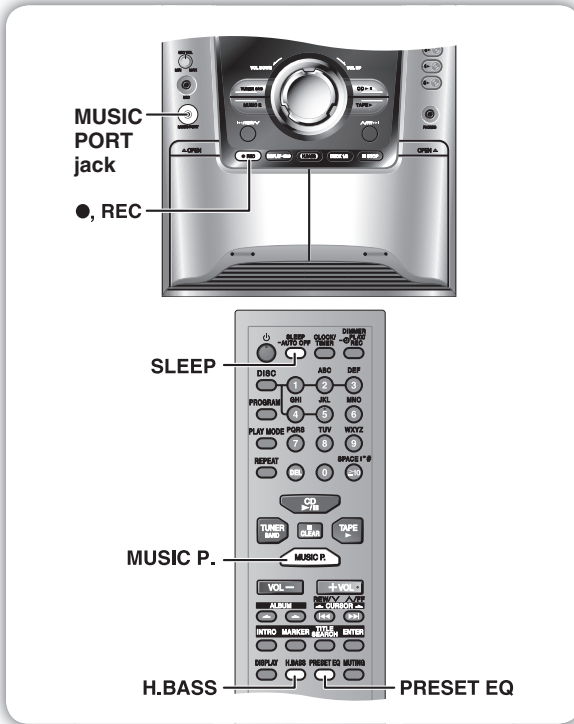

Using the sleep timer

This function enables you to turn off the unit automatically after the set time.

Press [SLEEP] to select your desired time.

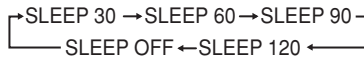

Sleep timer indicator

To cancel

Press [SLEEP] to select "SLEEP OFF".

Changing the remaining time

Press [SLEEP] to show the remaining time and press [SLEEP] again to select your desired time.

Note:

- The play and sleep timer or the record and sleep timer can be used together.
- The sleep timer always has priority. Be sure not to overlap timer settings.
- The sleep timer turns off when you perform the record function.

Selecting sound effects

Preset EQ

Press [PRESET EQ] repeatedly to select your desired setting.

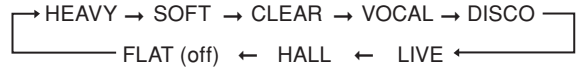

Setting	Effect
HEAVY	Adds punch to rock
SOFT	For background music
CLEAR	Clarifies higher frequencies
VOCAL	Adds gloss to vocal
DISCO	Produces sound with the same kind of lengthy reverberations heard at a disco
LIVE	Makes vocals more alive
HALL	Adds an expansiveness to the sound to produce the atmosphere of a great concert hall
FLAT	No effect

Enhancing the bass sound

You can enhance low-frequency sound so that heavy bass sound can be heard clearly, even if the acoustics of your room are not optimal.

To activate

Press [H.BASS].

To cancel

Press [H.BASS] again.

Note:

The actual effect depends on the disc.

External unit

Connecting to a portable audio equipment

This feature enables you to enjoy music from a portable audio equipment.



Playing from a portable audio equipment

Switch off the equalizer function (if there is any) of the portable audio equipment before you plug into the MUSIC PORT jack. Otherwise, sound from the speaker may be distorted.

- 1 Plug the audio cord into the MUSIC PORT jack and press [MUSIC P.].
- 2 Play the portable audio equipment. (See the portable audio equipment's instruction manual.)

Note:

All peripheral components and cables are sold separately.

Recording from a portable audio equipment

- 1 Press [MUSIC P.].
- 2 Play the portable audio equipment.
- 3 Press [●, REC] on the main unit to start recording.

Maintenance

If the surfaces are dirty

To clean this unit, wipe with a soft, dry cloth.

- Never use alcohol, paint thinner or benzine to clean this unit.
- Before using chemically treated cloth, read the instructions that came with the cloth carefully.

For a cleaner crisper sound (cassette deck)

Clean the heads regularly to assure good quality playback and recording. Use a cleaning tape (not included).

When moving the unit

- 1 Remove all discs.
- 2 Press [⏻/I, POWER] to turn the unit off.
- 3 Disconnect the AC power supply cord.

Troubleshooting guide

Before requesting service, make the following checks. If you can't fix the system as described below, or if something not listed here occurs, refer to the enclosed directory to locate an Authorized Service Center convenient to you or contact your dealer.

Reference pages are shown as black circled numbers ④.

Common problems

Although the unit is in standby mode, the display lights up and changes continuously.	Turn off the demo function. ⑤ If you set the clock, demo function will be turned off automatically. ⑮
No sound. Sound stops.	Turn the volume up. Switch off the unit, determine and correct the cause, then switch the unit on. Causes include shorting of the positive and negative speaker wires, straining of the speakers through excessive volume or power, and using the unit in a hot environment.
Sound is unfixed, reversed or comes from one speaker only.	Check the speaker connections. ④
Humming heard during play.	An AC power supply cord or fluorescent light is near the cables. Keep other appliances and cords away from this unit's cables.
"ERROR" is displayed.	Incorrect operation performed. Read the instructions and try again.
"- -: -" appears on the display at standby mode.	You plugged the AC power supply cord in for the first time or there was a power failure recently. Set the time. ⑮
"F61" is displayed.	Check and correct the speaker cords connection. ④ If this does not fix the problem, there is a power supply problem. Consult the dealer.

Listening to the radio

Noise is heard. The stereo indicator flickers or doesn't light. Sound is distorted.	Use an outdoor antenna. ⑤
A beat sound is heard.	Turn the TV off or separate it from the unit.
A low hum is heard during AM broadcast.	Separate the antenna from other cables and cords.

When there is a television set nearby

The picture on the TV disappears or stripes appear on the screen.	The location and orientation of the antenna are incorrect. If you are using an indoor antenna, change to an outdoor antenna. The TV antenna wire is too close to the unit. Separate the antenna wire of the TV set from the unit.
---	--

Using the cassette deck

Poor quality sound.	Clean the heads. ⑰
Recording is not possible.	If the erasure prevention tabs have been removed, cover the holes with adhesive tape. ⑱

Playing discs

The display is wrong or play won't start.	The disc may be upside down. ⑩ Wipe the disc. Replace the disc if it is scratched, warped, or non-standard. Condensation may have formed inside the unit due to a sudden change in temperature. Wait for about an hour for it to clear and try again.
The total number of tracks displayed differs each time the same disc is inserted. Unusual sound is heard.	The disc may be scratched, or its data may be defective. Replace the disc.
CD-RW cannot be read.	The disc was incompletely formatted. Use the recording equipment to fully format the disc before recording.
"VBR-" is displayed instead of the remaining play time.	The unit cannot display the remaining play time for variable bit rate (VBR) tracks.

Disc trays

Disc tray(s) cannot open. "CHGR ERR" is displayed.	Press [⏏/I, POWER] to release the jammed tray(s) as the unit will switch off. Switch it on again and the tray(s) will initialize to the previous tray(s) condition. If this still does not fix the problem, please consult the dealer.
---	---

Remote control

Remote control doesn't work.	Check that the batteries are inserted correctly. ⑥ Replace the batteries if they are worn.
------------------------------	---

Memory reset (Initialization)

When the following situations occur, refer to the instructions below to reset the memory:

- There is no response when buttons are pressed.
- You want to clear and reset the memory contents.

To reset memory

- 1 Disconnect the AC power supply cord. (Wait at least 3 minutes before proceeding to step 2)
- 2 While pressing and holding down [⏏/I, POWER] on the main unit, reconnect the AC power supply cord.

"-----" appears on the display.

- 3 Release [⏏/I, POWER].

All the settings are returned to the factory preset.
You will need to reset the memory items.

Specifications

AMPLIFIER SECTION **AK340**

RMS output power
THD 10%, both channels driven
1 kHz
 (Low channel) 105 W per channel (3 Ω)
10 kHz
 (High channel) 105 W per channel (3 Ω)
Total Bi-Amp power 420 W

AMPLIFIER SECTION **AK240**

RMS Output power
THD 10%, both channels driven
1 kHz 115 W per channel (3 Ω)
Total output power 230 W

FM/AM TUNER, TERMINALS SECTION

Preset station FM 15 stations
 AM 15 stations

Frequency Modulation (FM)
Frequency range 87.50 to 108.00 MHz (50 kHz step)
Sensitivity 4.0 μV (IHF)
S/N 26 dB 2.2 μV
Antenna terminal(s) 75 Ω (unbalanced)

Amplitude Modulation (AM)
Frequency range 522 to 1629 kHz (9 kHz step)
 520 to 1630 kHz (10 kHz step)
Sensitivity
S/N 20 dB (at 999 kHz) 560 μV/m

Music Port input jack
Terminal Stereo, 3.5 mm jack
Sensitivity 100 mV, 4.7 kΩ

Phone jack
Terminal Stereo, 3.5 mm jack

MIC jack
Terminal Mono, 3.5 mm jack
Sensitivity 0.7 mV, 680 Ω

CASSETTE DECK SECTION

Track system 4 track, 2 channel

Heads
Record/playback Solid permalloy head
Erasure Double gap ferrite head

Motor DC servo motor
Recording system AC bias 100 kHz
Erase system AC erase 100 kHz

Tape speed 4.8 cm/s
Overall frequency response (+3 dB, -6 dB)

at DECK OUT
NORMAL 35 Hz to 14 kHz
S/N Ratio 50 dB (A weighted)
Wow and flutter 0.18% (WRMS)

Fast forward and rewind time
 Approx. 120 seconds with
 C-60 cassette tape

DISC SECTION

Disc played [8 cm or 12 cm]
 (1) CD-Audio (CD-DA)
 (2) CD-R/RW
 (CD-DA, MP3, WMA formatted disc)
 (3) MP3/WMA

Bit rate
MP3, WMA 32 kbps to 320 kbps

Sampling frequency
MP3/WMA 32 kHz, 44.1 kHz, 48 kHz
CD-DA 44.1 kHz

Decoding 16 bit linear
Digital filter 8 fs

D/A converter MASH (1 bit DAC)

Pick up
Wavelength 780 nm
Beam Source Semiconductor laser

Audio output (Disc)
Number of channels 2 (Stereo) (FL, FR)

SPEAKER SECTION **AK340**

Type 3 way, 3 speaker system (Bass reflex)

Speaker(s)
Woofer 16 cm cone type
Tweeter 6 cm cone type
Super tweeter Piezo type

Impedance
HIGH 3 Ω
LOW 3 Ω

Input power (IEC)
HIGH 110 W (Max)
LOW 110 W (Max)

Output sound pressure level 83 dB/W (1.0 m)

Cross over frequency 2.6 kHz, 10 kHz
Frequency range 37 Hz to 23 kHz (-16 dB)
 44 Hz to 22 kHz (-10 dB)

Dimensions (WxHxD) 247 x 330 x 221 mm
Mass 3.4 kg

SPEAKER SECTION **AK240**

Type 2 way, 2 speaker system (Bass reflex)
Speaker(s)
Woofer 16 cm cone type
Tweeter 6 cm cone type
Impedance 3 Ω
Input power (IEC) 115 W (Max)
Output sound pressure level 83 dB/W (1.0 m)

Cross over frequency 4 kHz
Frequency range 38 Hz to 28 kHz (-16 dB)
 55 Hz to 26 kHz (-10 dB)

Dimensions (WxHxD) 220 x 330 x 208 mm
Mass 2.8 kg

GENERAL

Power supply AC 110 to 127/220 to 240 V, 50/60 Hz

Power consumption **AK340** : 120 W
AK240 : 95 W

Dimensions (WxHxD) 250 x 330 x 343 mm
Mass 6.9 kg

Operating temperature range +5 to +35 °C

Operating humidity range 5 to 90 % RH (no condensation)

Power consumption in standby mode: 0.6 W

- Note:**
- Specifications are subject to change without notice. Mass and dimensions are approximate.
 - Total harmonic distortion is measured by the digital spectrum analyzer.
 - AK340** The labels "HIGH" and "LOW" on the rear of the speakers refer to High frequency and Low frequency.

