

The illustration shows SC-HT995.



Operating Instructions

DVD Home Theater Sound System

Model No. **SC-HT995/SC-HT995W**

Region number

The player plays DVD-Video marked with labels containing the region number or "ALL".

Region	Number
The Middle East, South Africa, Saudi Arabia and Kuwait	2
Southeast Asia and Thailand	3
Australia and N.Z.	4

Example:

Southeast Asia and Thailand



Before connecting, operating or adjusting this product, please read the instructions completely. Please keep this manual for future reference.

GCS GCT GC GS

*Wireless system and digital transceiver** page **11**

Wireless surround speaker connection. (* For SC-HT995W only.)

High-quality picture page **13**

HDMI capability, Advanced progressive scan and more.

Compatible with a variety of media formats page **17**

DVD-RAM, DVD-Audio, DVD-Video, DivX and more.

High-performance sound effects page **34**

Sound quality enhancement, Bass enhancement and more.

Dear customer

Thank you for purchasing this product. For optimum performance and safety, please read these instructions carefully.

- These operating instructions are applicable to models SC-HT995 and SC-HT995W for a variety of regions.
- Unless otherwise indicated, illustrations in these operating instructions are of SC-HT995.
- Operations in these instructions are described mainly with the remote control, but you can perform the operations on the main unit if the controls are the same.

HT995: indicates features applicable to SC-HT995 only.

HT995W: SC-HT995W only

System	SC-HT995	SC-HT995W
Main unit	SA-HT995	SA-HT995
Front speakers	SB-FS995	SB-FS990
Center speaker	SB-PC995	SB-PC895
Surround speakers	SB-FS996	SB-FS540
Subwoofer	SB-W995	SB-W895
Wireless system	-	SE-FX61
Digital transceiver	-	SH-FX80T

Accessories

Please check and identify the supplied accessories.



- 1 Remote control
(N2QAYZ000003)



- 2 Remote control batteries



- 1 AM loop antenna



- 1 FM indoor antenna



- 1 Video cable



- Speaker cables

HT995
2×short cable
HT995W
1×short cable



- 2 Sheets of speaker cable stickers



- HT995** 4 Stands
2×stands with short cable
2×stands with long cable



- HT995** 4 Bases



- HT995** 12 Screws



- HT995** 4 Sliders



- HT995W** 4 Stands
2×stands with short cable
2×stands with long cable



- HT995W** 4 Bases



- HT995W** 16 Screws



- HT995W** 4 Cover plates



- HT995**
AC mains lead
Southeast Asia, Thailand,
the Middle East, South Africa,
Saudi Arabia and Kuwait



Saudi Arabia and Kuwait



HT995W
2 AC mains leads



TABLE OF CONTENTS

Getting Started



Accessories	2
Caution for AC Mains Lead	4
Safety precautions	5
About DivX VOD content	5
Simple Setup	
STEP 1 Assembling the front and surround speakers	6
Speaker installation options	8
STEP 2 Positioning the speakers	9
STEP 3 Speaker connections	11
HT995W Connecting the surround speaker cables to the wireless system	11
STEP 4 Radio and digital transceiver connections	12
HT995W Connecting the digital transceiver	12

STEP 5 Audio and video connections	13
Television with an HDMI terminal	13
Basic audio connection	13
Basic video connection	13



Playing Discs



Basic play	18
Using the main unit	18
Using the remote control	19
Convenient functions	20
Displaying current playback condition	20
All group, Program and Random play	20
Playing data discs using navigation menus	21
Playing data discs	21
Selecting a track using CD text	22
Playing HighMAT™ discs	22
Playing RAM and DVD-R/-RW (DVD-VR) discs	22

Using on-screen menus	24
Main menu	24
Other Settings	25
Changing the player settings	28
Changing the delay time of the speakers	31



Other Operations



Using the radio	32
Presetting stations automatically	32
Selecting the preset channels	32
Manual tuning	32
Using an outdoor antenna (optional)	33
Using sound effects	34
Changing the sound quality: Sound Field Control	34
Enhancing the sound from the center speaker:	
Center Focus	34
Enhancing the stereo sound: Dolby Pro Logic II	34
Adjusting the amount of bass: Subwoofer level	34
Enhancing the bass sound: H.BASS	35
Enhancing the surround sound effect:	
Surround Enhancer	35
Adjusting the volume of each speaker:	
Speaker level adjustments	35

Using other useful functions	36
Setting the sleep timer	36
Muting the sound	36
Using headphones	36
Using the Music Port	36
HT995 Enjoying Karaoke	37
Operating other equipment	38
Operating the television	38
HT995W Operating the cable TV box, digital broadcasting or satellite receiver	38
Operating both the television and the home theater system: Control with HDMI (HDAVI Control™)	39
One Touch Play	39
Automatic input switching	39
Theater speaker	39
Power off link	39



Reference



Troubleshooting guide	40
Glossary	43

Specifications	44
-----------------------------	----



Caution for AC Mains Lead





(For Saudi Arabia and Kuwait) ("GS" area code model only)

For your safety, please read the following text carefully.

This appliance is supplied with a moulded three pin mains plug for your safety and convenience.

A 5-ampere fuse is fitted in this plug.

Should the fuse need to be replaced please ensure that the replacement fuse has a rating of 5-ampere and that it is approved by ASTA or BSI to BS1362.

Check for the ASTA mark  or the BSI mark  on the body of the fuse.

If the plug contains a removable fuse cover you must ensure that it is refitted when the fuse is replaced.

If you lose the fuse cover the plug must not be used until a replacement cover is obtained.

A replacement fuse cover can be purchased from your local dealer.

CAUTION!

IF THE FITTED MOULDED PLUG IS UNSUITABLE FOR THE SOCKET OUTLET IN YOUR HOME THEN THE FUSE SHOULD BE REMOVED AND THE PLUG CUT OFF AND DISPOSED OF SAFELY. THERE IS A DANGER OF SEVERE ELECTRICAL SHOCK IF THE CUT OFF PLUG IS INSERTED INTO ANY 13-AMPERE SOCKET.

If a new plug is to be fitted please observe the wiring code as stated below.

If in any doubt please consult a qualified electrician.

IMPORTANT

The wires in this mains lead are coloured in accordance with the following code:

Blue: Neutral, Brown: Live.

As these colours may not correspond with the coloured markings identifying the terminals in your plug, proceed as follows:

The wire which is coloured Blue must be connected to the terminal which is marked with the letter N or coloured Black or Blue.

The wire which is coloured Brown must be connected to the terminal which is marked with the letter L or coloured Brown or Red.

WARNING: DO NOT CONNECT EITHER WIRE TO THE EARTH TERMINAL WHICH IS MARKED WITH THE LETTER E, BY THE EARTH SYMBOL  OR COLOURED GREEN OR GREEN/YELLOW.

THIS PLUG IS NOT WATERPROOF—KEEP DRY.

Before use

Remove the connector cover.

How to replace the fuse

The location of the fuse differ according to the type of AC mains plug (figures A and B). Confirm the AC mains plug fitted and follow the instructions below.

Illustrations may differ from actual AC mains plug.

1. Open the fuse cover with a screwdriver.

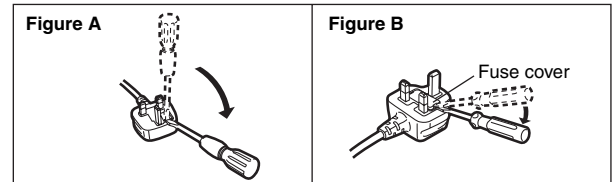

2. Replace the fuse and close or attach the fuse cover.

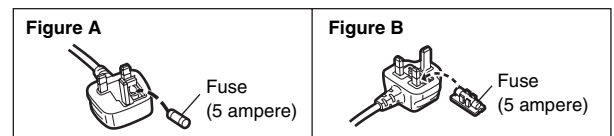

Safety precautions

Placement

Set the unit up on an even surface away from direct sunlight, high temperatures, high humidity, and excessive vibration. These conditions can damage the cabinet and other components, thereby shortening the unit's service life.
Do not place heavy items on the unit.

Voltage

Do not use high voltage power sources. This can overload the unit and cause a fire.
Do not use a DC power source. Check the source carefully when setting the unit up on a ship or other places where DC is used.

AC mains lead protection

Ensure the AC mains lead is connected correctly and not damaged. Poor connection and lead damage can cause fire or electric shock. Do not pull, bend, or place heavy items on the lead.
Grasp the plug firmly when unplugging the lead. Pulling the AC mains lead can cause electric shock.
Do not handle the plug with wet hands. This can cause electric shock.

Foreign matter

Do not let metal objects fall inside the unit. This can cause electric shock or malfunction.
Do not let liquids get into the unit. This can cause electric shock or malfunction. If this occurs, immediately disconnect the unit from the power supply and contact your dealer.
Do not spray insecticides onto or into the unit. They contain flammable gases which can ignite if sprayed into the unit.

Service

Do not attempt to repair this unit by yourself. If sound is interrupted, indicators fail to light, smoke appears, or any other problem that is not covered in these instructions occurs, disconnect the AC mains lead and contact your dealer or an authorized service center. Electric shock or damage to the unit can occur if the unit is repaired, disassembled or reconstructed by unqualified persons.

Extend operating life by disconnecting the unit from the power source if it is not to be used for a long time.

About DivX VOD content

DivX Video-on-Demand (VOD) content is encrypted for copyright protection. In order to play DivX VOD content on this unit, you first need to register the unit.

Follow the online instructions for purchasing DivX VOD content to enter the unit's registration code and register the unit. For more information about DivX VOD, visit www.divx.com/vod.

Display the unit's registration code (→ page 30, "DivX Registration" in "Others" tab)

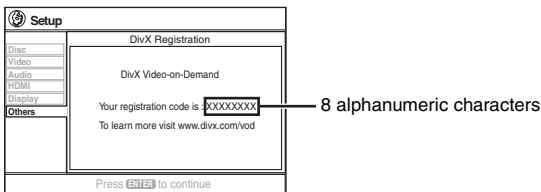

- We recommend that you make a note of this code for future reference.
- After playing DivX VOD content for the first time, another registration code is then displayed in "DivX Registration". Do not use this registration code to purchase DivX VOD content. If you use this code to purchase DivX VOD content, and then play the content on this unit, you will no longer be able to play any content that you purchased using the previous code.
- If you purchase DivX VOD content using a registration code different from this unit's code, you will not be able to play this content. ("Authorization Error" is displayed.)

Regarding DivX content that can only be played a set number of times

Some DivX VOD content can only be played a set number of times. When you play this content, the remaining number of plays is displayed. You cannot play this content when the number of remaining plays is zero. ("Rented Movie Expired" or "Rental Expired" is displayed.)

When playing this content

- The number of remaining plays is reduced by one if
 - you press [⏪] or press and hold [—SETUP].
 - you press [■ STOP]. (Press [⏸ PAUSE] to pause play.)
 - you press [⏮ SKIP] or [⏭ SLOW/SEARCH] etc. and arrive at another content or the start of the content being played.
- Resume (→ page 19, Stop) and Marker (→ page 25, Play Menu) functions do not work.



STEP 1

Assembling the front and surround speakers

The supplied stands are specially designed for attachment to Panasonic SB-FS995 front speakers, SB-FS996 surround speakers or SB-FS990 front speakers, SB-FS540 surround speakers. Use only as indicated in this setup.

Preparation

- To prevent damage or scratches, lay down a soft cloth and perform assembly on it.
- For assembly, use a Phillips-head screwdriver.
- Make sure you have all the indicated components before starting assembly, setup, and connection.
- There is no difference between the right and left speakers and stands.
- For optional wall mount, refer to page 8.

HT995

Note

- The front and surround speakers are different.
 - Check the label on the rear of speaker before attaching the stand (→ page 9).
 - The stand with shorter cable is for the front speaker.

2 Front speakers and
2 Surround speakers

4 Stands

4 Bases

12 Screws

4 Sliders

- 2×stands with short cable:
For front speakers
- 2×stands with long cable:
For surround speakers

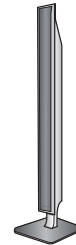

The speaker height
can be adjusted.
Min: 110 cm
Max: 135 cm

1 Attach the speaker to the stand.

Place the polyfoam underneath the speaker for stability while attaching the speaker to the stand.

- 1 Feed the speaker cable (the shorter part) into the bottom of the speaker and through the slot at the rear.
- 2 While pulling the speaker cable up through the slot, slide the speaker stand into the bottom of the speaker.

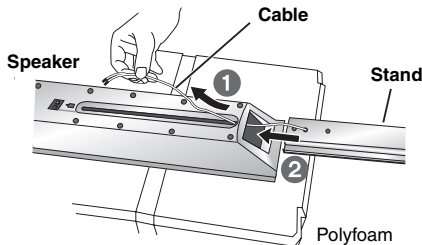

- 3 Thread the cable through the middle hole of the slider and fasten the slider with the two screws.

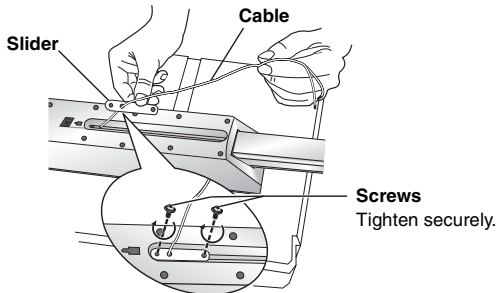

2 Attach the stand to the base.

- 1 Thread the speaker cable through the base.

For quicker threading, loosely fold the cable in half (do not crease), pass the folded portion through the hole, and then pull the rest of the cable through the base.

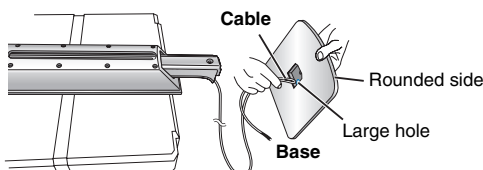

- 2 Insert the stand into the base while gently pulling on the end of the cable.

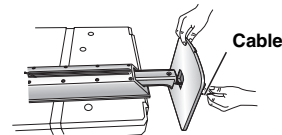

- 3 Secure the stand to the base.

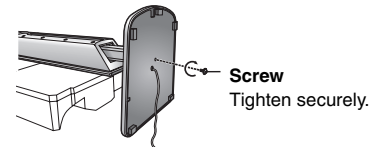

- 4 Adjust the speaker height.

- 1 Loosen the screws until the speaker can slide up and down the stand.
- 2 Raise the speaker to the desired height, and then re-tighten the screws.

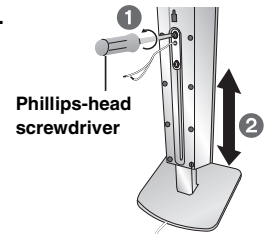

- 5 Connect the speaker cable.

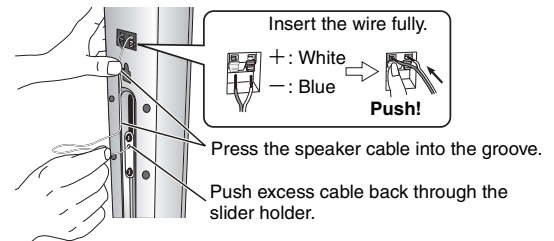

- 6 Secure the speaker cable to the base.

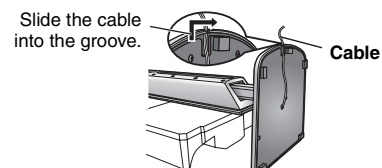

Note

- The front and surround speakers are different.
- Check the label on the rear of speaker before attaching the stand (→ page 9).
- The stand with shorter cable is for the front speaker.

**2 Front speakers and
2 Surround speakers
(with cover plate)**

4 Stands

- 2×stands with short cable:
For front speakers
- 2×stands with long cable:
For surround speakers

4 Bases

16 Screws



1 Attach the stand to the base.

① Thread the speaker cable through the base.

For quicker threading, loosely fold the cable in half (do not crease), pass the folded portion through the hole, and then pull the rest of the cable through the base.

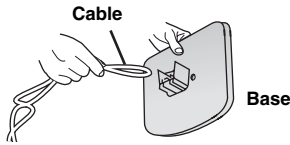

② Attach the stand to the base while gently pulling on the end of the speaker cable.

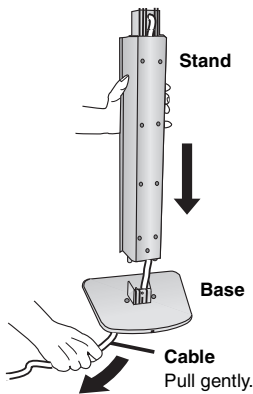

2 Secure the stand to the base.

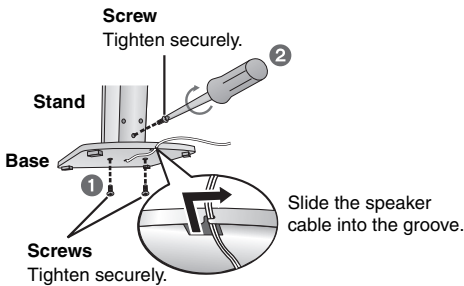

3 Attach the speaker to the stand.

① Pull out the end of the speaker cable and position it between the ridges.

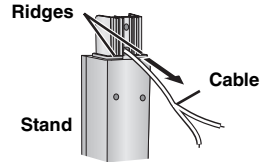

② Attach the speaker to the stand.

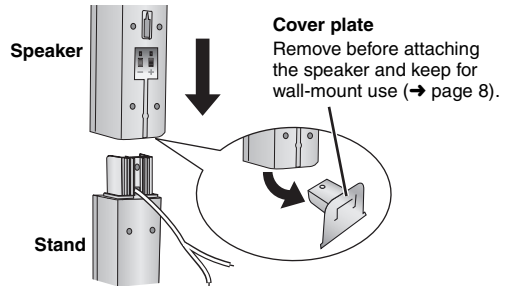

4 Secure the speaker to the stand.

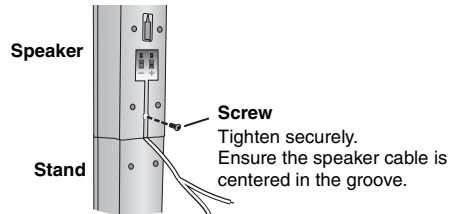

5 Connect the speaker cable.

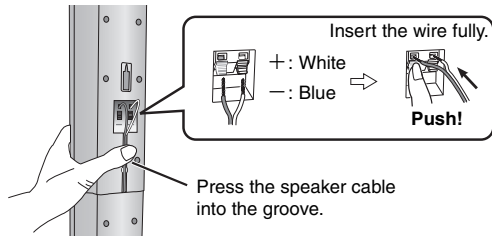

Preventing the speakers from falling

- You will need to obtain the appropriate screw eyes to match the walls or pillars to which they are going to be fastened.
- Consult a qualified housing contractor concerning the appropriate procedure when attaching to a concrete wall or a surface that may not have strong enough support. Improper attachment may result in damage to the wall or speakers.

e.g. HT995

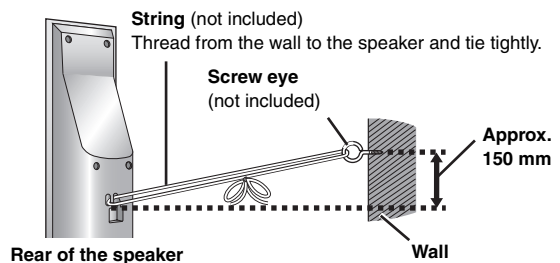

Speaker installation options

■ Attaching to a wall

You can attach all of the speakers (except subwoofer) to a wall.

- The wall or pillar on which the speakers are to be attached should be capable of supporting over 15 kg (HT995W 10 kg) per screw. Consult a qualified building contractor when attaching the speakers to a wall. Improper attachment may result in damage to the wall and speakers.
- When mounting the front speakers or surround speakers to a wall, we recommend using a string (not included) to prevent it from falling.

HT995W 4 Screws

HT995W 4 Cover plates



Preparation for front and surround speakers

HT995

- 1 Pull down the longer part of the cable to release the cable from the groove inside the stand, and then pull the speaker cable out from the stand.
- 2 Feed the cable into the bottom of the speaker and through the slot at the rear.
- 3 Connect the cable (→ page 6).

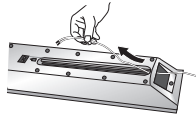

HT995W

- 1 Remove the speaker cable from the stand.

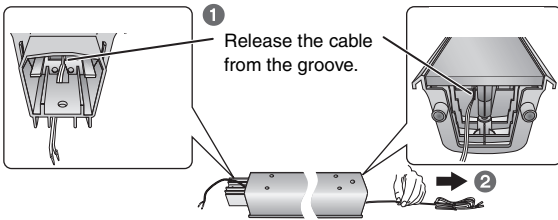

- 2 Connect the cable (→ page 7).

- ① HT995W Attach the cover plate to the front speaker or surround speaker.

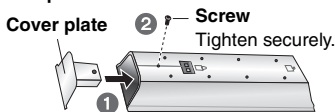

- ② Drive a screw (not included) into the wall.

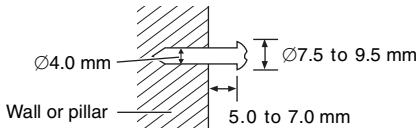

- ③ Fit the speaker securely onto the screw(s) with the hole(s).

Front and surround speaker HT995

Center speaker HT995

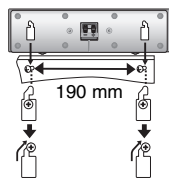
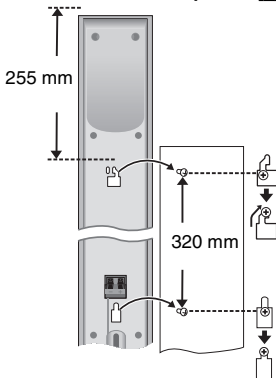

Front and surround speaker HT995W

Center speaker HT995W

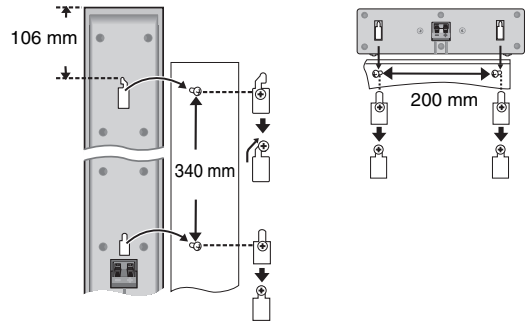

e.g.



In this position, the speaker will likely fall if moved to the left or right.



Move the speaker so that the screw is in this position.

Reattaching the speaker cable to the stand

HT995

- 1 Remove the two screws from the stand, and remove the metal cover.

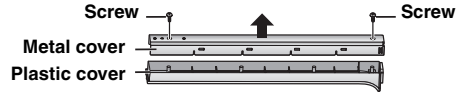

- 2 Pull the cable out about 40 cm from the hole in the metal cover, and insert the plastic cover.

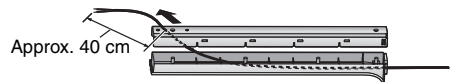

- 3 Insert the metal cover so it does not disturb the cable and close tightly with the two screws.

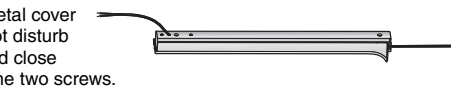

HT995W

- 1 Remove the eight screws from the stand, and remove the speaker net.

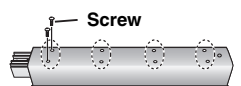

- 2 Position the cable.

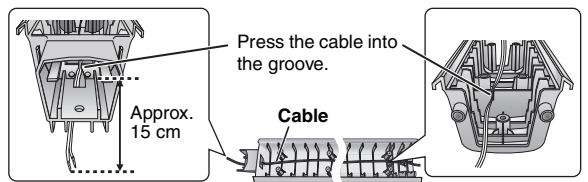

- 3 Attach the speaker net with the screws.

■ Fitting speaker stands (not included)

(For center speaker)

Ensure the stands meet these conditions before purchasing them. Note the diameter and length of the screws and the distance between screws as shown in the diagram.

- The stands must be able to support over 10 kg.
- The stands must be stable even if the speakers are in a high position.

e.g. Center speaker HT995

Metal screw holes

For attaching to speaker stands

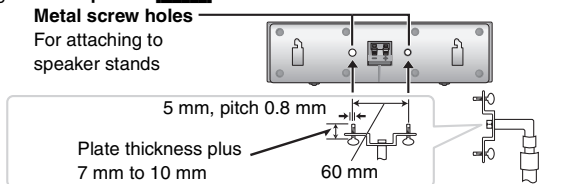

Speaker stand (not included)

STEP 2 Positioning the speakers

How you set up your speakers can affect the bass and the sound field. Note the following points:

- Place speakers on flat secure bases.
- Placing speakers too close to floors, walls, and corners can result in excessive bass. Cover walls and windows with thick curtains.
- Left and right speakers are interchangeable, but front and surround speakers are not.
- Place the front, center, and surround speakers at approximately the same distance from the seating position. The angles in the diagram are approximate.

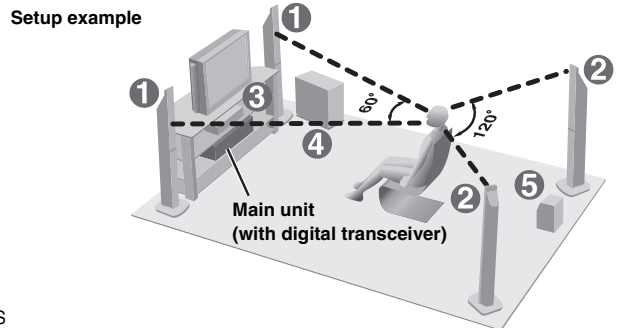
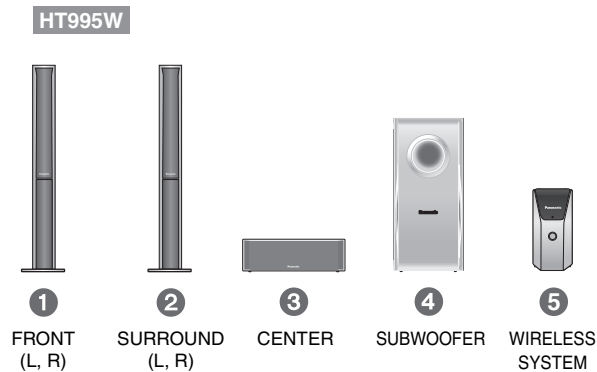
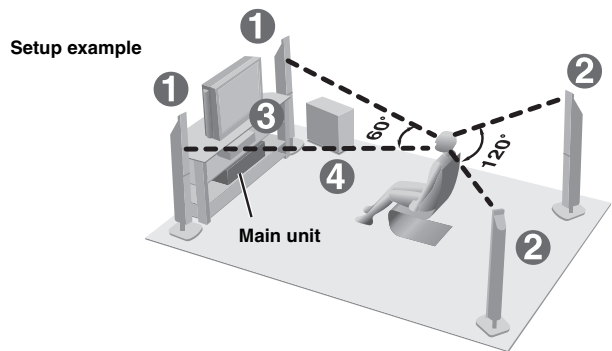
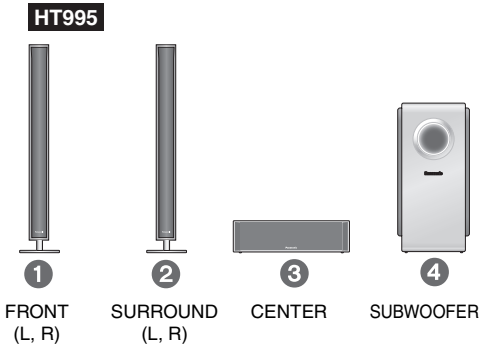

Note

Do not use a front speaker as a surround speaker or vice versa. Verify the type of speaker with the label on the rear of the front speaker.

e.g. **HT995**

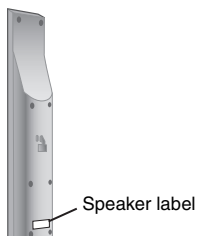

(Continued on next page)

Use only supplied speakers

- Using other speakers can damage the unit, and sound quality will be negatively affected.
- Set the speakers up on an even surface to prevent them from falling. Take proper precautions to prevent the speakers from falling if you cannot set them up on an even surface.

Main unit**Note**

- Keep your speakers at least 10 mm away from the system for proper ventilation.
- To allow for proper ventilation and to maintain good airflow around the main unit, position it with at least 5 cm of space on all sides.
- Do not block the ventilation holes of the main unit.

Center speaker

- Vibration caused by the center speaker can disrupt the picture if it is placed directly on the television. Put the center speaker on a rack or shelf.
- To prevent the speakers from falling, do not place directly on top of the television.

HT995W Wireless system

- Place the wireless system within approximately 10 m from the main unit.
- Do not use the wireless system or the digital transceiver in a metal cabinet or bookshelf.

Subwoofer

Place to the right or left of the television, on the floor or a sturdy shelf so that it will not cause vibration. Leave about 30 cm from the television.

Caution

- Do not stand on the base. Be cautious when children are near.

e.g. **HT995** Front speaker



- Do not touch the netted area of the speakers. e.g. **HT995** Center speaker

**Notes on speaker use**

- You can damage your speakers and shorten their useful life if you play sound at high levels over extended periods.
- Reduce the volume in the following cases to avoid damage:
 - When playing distorted sound.
 - When the speakers are reverberating due to a record player, a microphone (**HT995** only), noise from FM broadcasts, or continuous signals from an oscillator, test disc, or electronic instrument.
 - When adjusting the sound quality.
 - When turning the unit on or off.

If irregular coloring occurs on your television

The front and center speakers are designed to be used close to a television, but the picture may be affected with some televisions and setup combinations.

If this occurs, turn the television off for about 30 minutes.

The demagnetizing function of the television should correct the problem. If it persists, move the speakers further away from the television.

Caution

- The main unit and supplied speakers are to be used only as indicated in this setup. Failure to do so may lead to damage to the amplifier and/or the speakers, and may result in the risk of fire. Consult a qualified service person if damage has occurred or if you experience a sudden change in performance.
- Do not attempt to attach these speakers to walls using methods other than those described in this manual.

HT995W Avoiding interference

To avoid possible interference, do not place the wireless system near any of the following devices.

The wireless system uses the same radio frequencies as other devices that may be present in your home.

e.g.

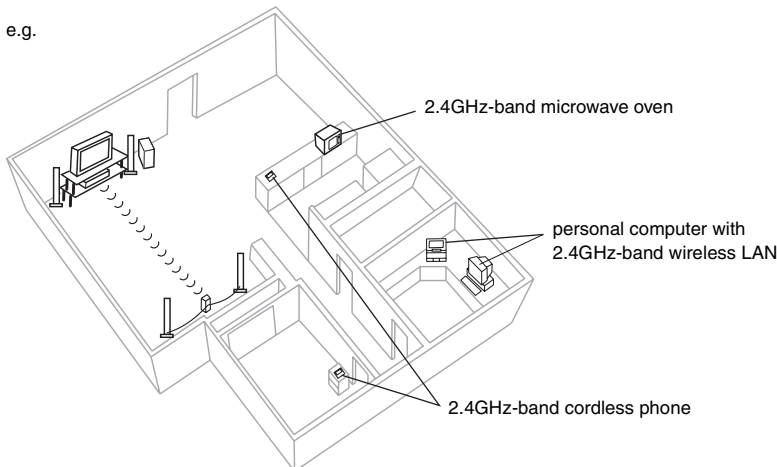

The wireless system will automatically seek a clear channel if any of these other devices interfere with its communication. When this happens, the wireless link indicator (“**W**”) flashes on the main unit, and there is a brief interruption in audio coming from the surround speakers.

This is the normal operation of the product working to assure the best possible performance of your Home Theater System.

If the interference persists, try moving the other devices to another location outside the range of the wireless system.

STEP 3 Speaker connections

HT995

Speaker cables

- 2× short cable:
For center speaker and subwoofer



HT995W

Speaker cables

- 1× short cable:
For center speaker



2 sheets of speaker cable stickers

- Attach the speaker-cable stickers to make connection easier.

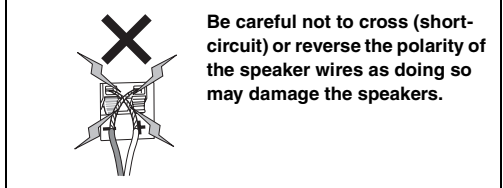

Be careful not to cross (short-circuit) or reverse the polarity of the speaker wires as doing so may damage the speakers.

The illustration shows SC-HT995.

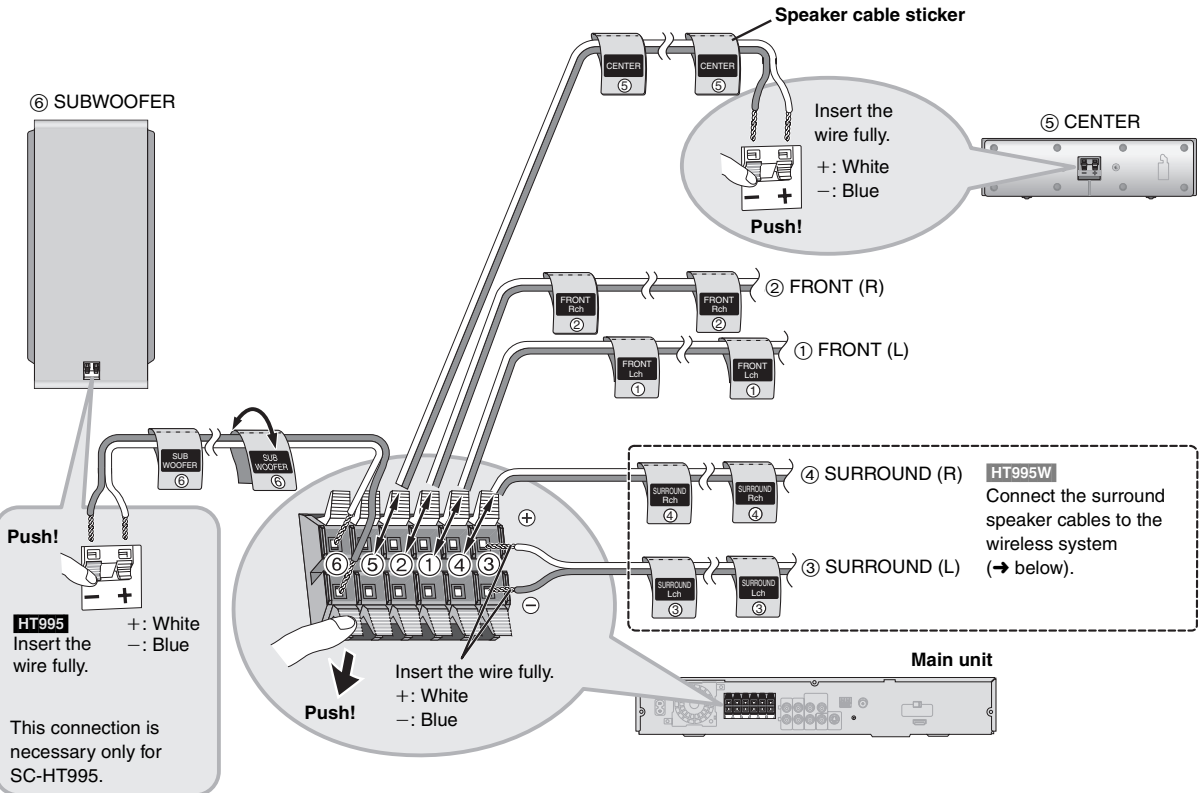

HT995W Connecting the surround speaker cables to the wireless system

Wireless system

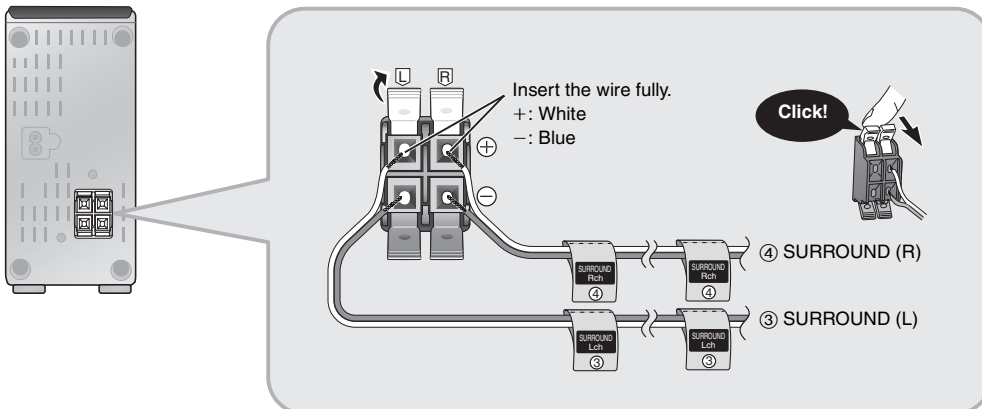

STEP 4 Radio and digital transceiver connections

AM loop antenna



FM indoor antenna



HT995W Digital transceiver



• Using an outdoor antenna (optional) (→ page 33).

The illustration shows SC-HT995.

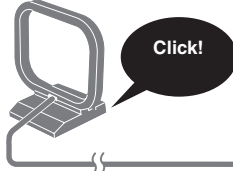
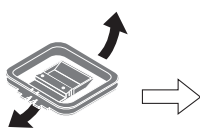

AM loop antenna

Stand the antenna up on its base.
Place the antenna where reception is best.
Keep loose antenna cable away from other wires
and cables.

FM indoor antenna

Affix this end of the antenna where
reception is best.

Adhesive tape

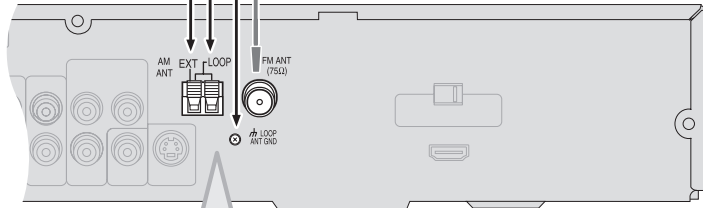
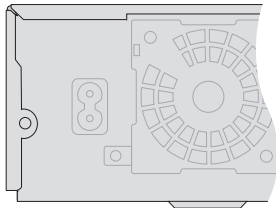

Main unit

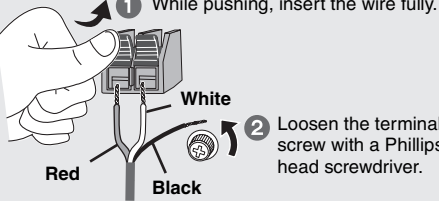

White
Red
Black

2 Loosen the terminal
screw with a Phillips-
head screwdriver.

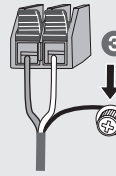

4 Re-tighten the
terminal screw.

HT995W Connecting the digital transceiver

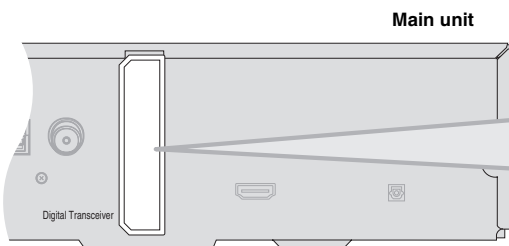

Main unit

Digital Transceiver

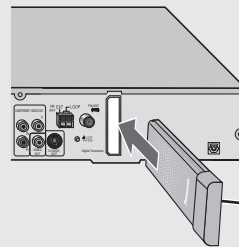

Insert the digital transceiver
into the slot.

**Do not insert or remove
while the main unit is on.**

Digital transceiver

Insert fully until you hear a click.

STEP 5 Audio and video connections

- Do not connect through the video cassette recorder.
Due to copy guard protection, the picture may not be displayed properly.
- Turn the television off before connecting, and refer to the television's operating instructions.

Video cable



Television with an HDMI terminal

HDMI-compatible television
(not included)

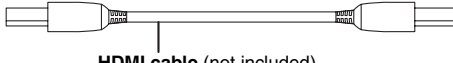

HDMI cable (not included)



Back of the main unit

Use the HDMI connection to enjoy higher quality audio and video with a single cable (→ page 43, HDMI).

- Set "Video Output" to "On" and "Audio Output" to "On" (→ page 30, "HDMI" tab).
- Set "Video Output Mode" (→ page 25, Picture Menu).

Control with HDMI (HDAVI Control)

If your Panasonic television is an HDMI control compatible television, you can operate your television synchronizing with home-theater operations or vice versa [→ page 39, Operating both the television and the home theater system: Control with HDMI (HDAVI Control™)].

Note

- Make the extra audio connection (→ below) when you use HDAVI Control function.
- It is recommended that you use Panasonic's HDMI cable.
[Recommended part number: RP-CDHG15 (1.5 m), RP-CDHG30 (3.0 m), RP-CDHG50 (5.0 m), etc.]
- Non-HDMI-compliant cables cannot be utilized.

Basic audio connection

Television
(not included)

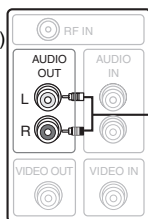

Audio cable
(not included)

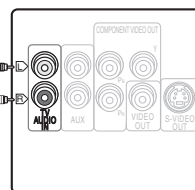

Back of the main unit

- This audio connection will enable you to play audio from your television through your home theater system.
Refer to "Operating other equipment" (→ page 38).
- You can also connect to the AUX terminals on the main unit. The TV AUDIO IN and AUX terminals are for external audio input.

Basic video connection

Television
(not included)



Video cable
(included)

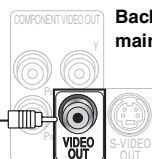

Back of the main unit

Other video connections for improved picture quality

COMPONENT VIDEO OUT

Television
(not included)

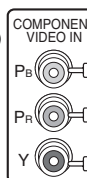

Video cables (not included)

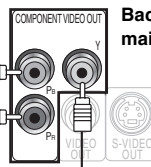

Back of the main unit

Using the COMPONENT VIDEO OUT terminals

The COMPONENT VIDEO OUT terminals provides a purer picture than the S-VIDEO OUT terminal. These terminals can be used for either interlaced or progressive output. Connection using these terminals outputs the color difference signals (P_B/P_R) and luminance signal (Y) separately in order to achieve high fidelity in reproducing colors.

- The description of the component video input terminals depends on the television or monitor (e.g. Y/P_B/P_R, Y/B-Y/R-Y, Y/C_B/C_R).
Connect to terminals of the same color.

To enjoy progressive video

- Connect to a progressive output compatible television.
 - ① Set "Video Output" to "Off" (→ page 30, "HDMI" tab).
 - ② Set "Video Output Mode" to "480p" or "576p", and then follow the instructions on the menu screen (→ page 25, Picture Menu).

(Continued on next page)



Simple Setup

Audio and video connections

Other video connections for improved picture quality

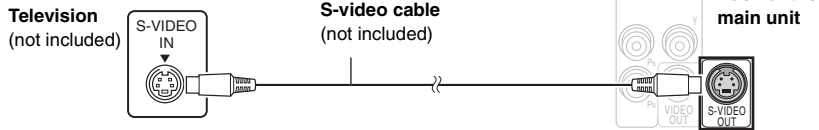
S-VIDEO OUT

• Using the S-VIDEO OUT terminal

The S-VIDEO OUT terminal achieves a more vivid picture than the VIDEO OUT terminal by separating the chrominance (C) and luminance (Y) signals. (Actual results depend on the television.)

■ Cable TV box or video cassette recorder connection

Cable TV box or video cassette recorder (not included)

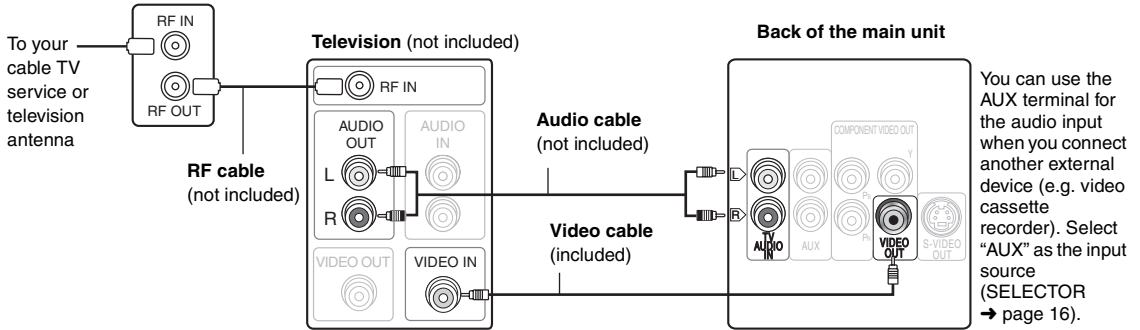
**STEP 6 AC mains lead connections****AC mains lead**

Southeast Asia, Thailand, the Middle East, South Africa, Saudi Arabia and Kuwait



Saudi Arabia and Kuwait



HT995W

2 AC mains leads



• Connect the AC mains lead after all other connections are complete.

The illustration shows SC-HT995.

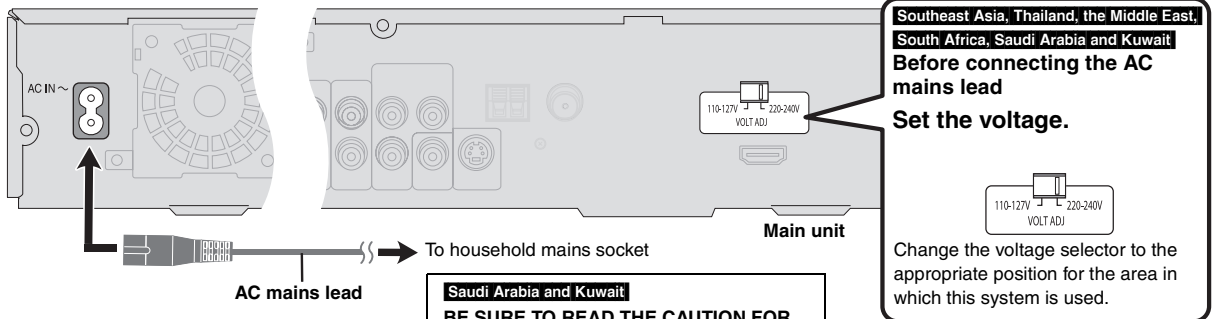

Southeast Asia, Thailand, the Middle East, South Africa, Saudi Arabia and Kuwait
Before connecting the AC mains lead

Set the voltage.

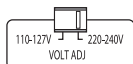

Change the voltage selector to the appropriate position for the area in which this system is used.

Saudi Arabia and Kuwait

BE SURE TO READ THE CAUTION FOR THE AC MAINS LEAD ON PAGE 4 BEFORE CONNECTION.

HT995W

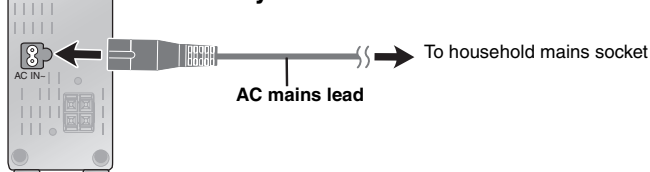
Wireless system**Conserving power**

The main unit and the wireless system consume a small amount of power when they are in standby mode (main unit: For Southeast Asia, Thailand, the Middle East, South Africa, Saudi Arabia and Kuwait: approx. 0.65 W or for Australia and N.Z.: approx. 0.5 W, HT995W wireless system: approx. 0.5 W). To save power when they are not to be used for a long time, unplug them from the household mains socket. You will need to reset some memory items after plugging in the main unit.

Note

The included AC mains leads are for use with the main unit and wireless system only. Do not use them with other equipment. Also, do not use cords for other equipment with the main unit or wireless system.

STEP 7

Preparing the remote control

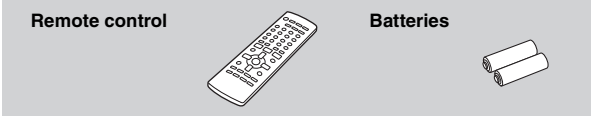

2 Insert so the poles (+ and -) match those in the remote control.

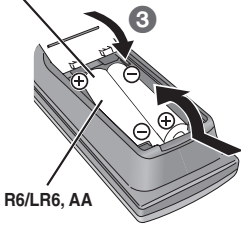

1 Do not use rechargeable type batteries.

Do not:

- mix old and new batteries.
 - use different types at the same time.
 - heat or expose to flame.
 - take apart or short circuit.
 - attempt to recharge alkaline or manganese batteries.
 - use batteries if the covering has been peeled off.
- Mishandling of batteries can cause electrolyte leakage which can severely damage the remote control.

Remove the batteries if the remote control is not going to be used for a long period of time. Store in a cool, dark place.

Use

Aim at the remote control signal sensor (→ page 16), avoiding obstacles, at a maximum range of 7 m directly in front of the unit.

STEP 8

Performing QUICK SETUP

The QUICK SETUP screen assists you to make necessary settings.

To display the picture from the main unit, turn on your television and change its video input mode (e.g. VIDEO 1, AV 1, etc.).

- To change your television's video input mode, refer to its operating instructions.
- This remote control can perform some basic television operations (→ page 38).

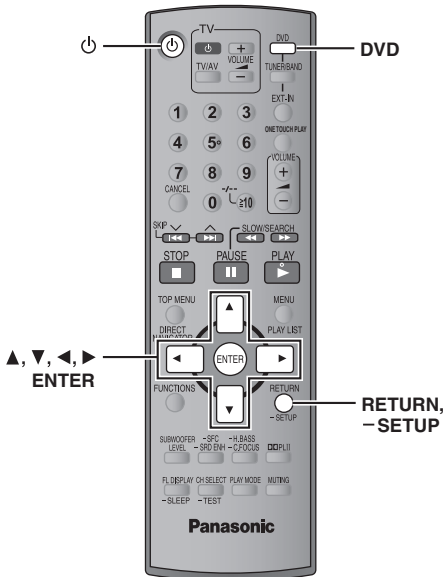

1		Turn on the unit.
2		Select "DVD/CD".
3		Press and hold to show the QUICK SETUP screen.
4	<p>Select</p> <p>Register</p>	Follow the messages and make the settings.
5		Press to finish QUICK SETUP.
6		Press repeatedly to exit.

To change these settings later

Select "QUICK SETUP" in the "Others" tab (→ page 30).



See page references in parentheses.

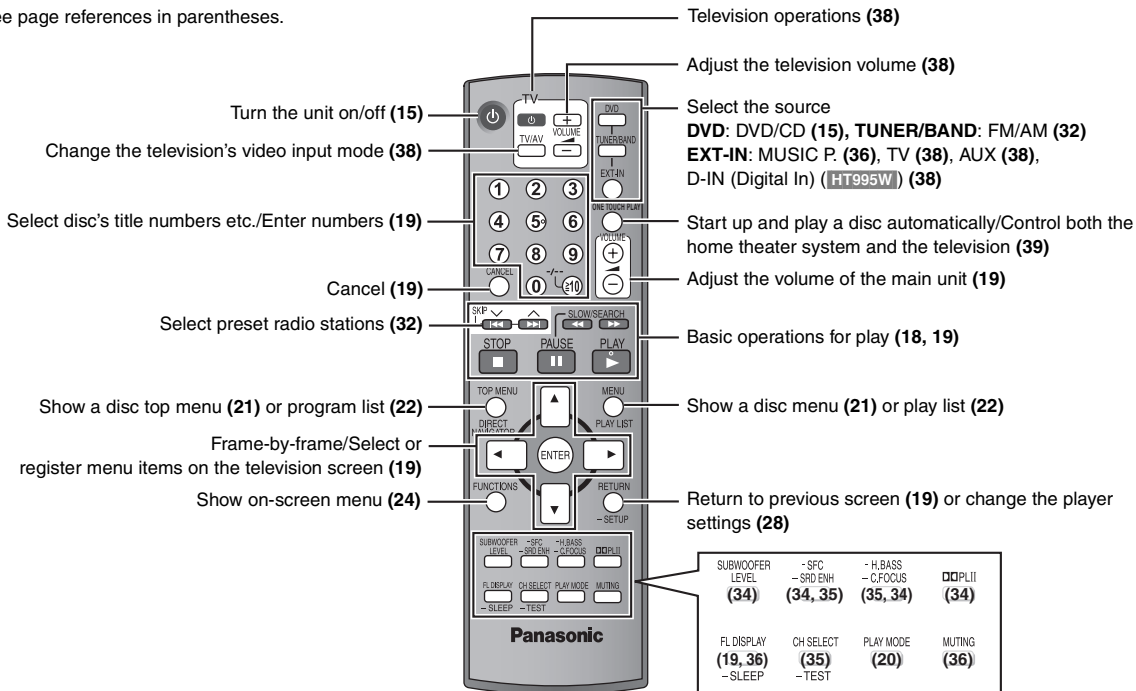

To use functions labeled with "—":
Press and hold the button for at least 2 seconds.

MUSIC PORT

Connect an external device (36)

Standby/on switch [⏻/⏻]

Press to switch the unit from on to standby mode or vice versa. In standby mode, the unit is still consuming a small amount of power. (18)

SURROUND ENHANCER

Enhancing the surround sound effect (18)

MIC LEVEL HT995

Adjust the microphone volume (37)

MIC jack HT995

Connect a microphone (37)

▲ OPEN/CLOSE

Open/Close the disc tray (18)

⏮/⏪, ⏩/⏭ / √ TUNING ▲

Skip or slow-search play (18)/
Select the radio stations (32)

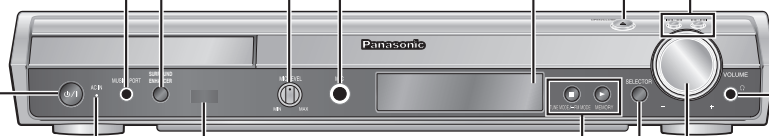

Phones

Connect headphones (36)

VOLUME

Turn up/down the volume (18)

AC supply indicator [AC IN]

This indicator lights when the unit is connected to the AC mains supply.

■ / - TUNE MODE / — FM MODE

Stop playing (18)/Select the tuning mode (32)
Adjust the FM reception condition (32)

▶ / MEMORY

Play discs (18)/Memorize the receiving radio stations (32)

SELECTOR (32)

DVD/CD→FM→AM→TV→AUX→
D-IN (Digital In) (HT995W)→MUSIC P.→
Return to DVD/CD

HT995W

The illustration shows the wireless system for SC-HT995W.

AC supply indicator [AC IN]

This indicator lights when the unit is connected to the AC mains supply.

The unit is in the standby condition when the AC power supply cord is connected. The primary circuit is always "live" as long as the power cord is connected to an electrical outlet.









Lighting Ring

Lights when the wireless link is active.

Discs that can be played

Operations in these instructions are described mainly with formats. Icons such as **DVD-V** show the formats.

	DVD-Video DVD-V —
	DVD-Audio DVD-A DVD-V ● DVD-V Some DVD-Audio discs contain DVD-Video content. To play DVD-Video content, select "Play as DVD-Video" in Other Menu (→ page 27).
	Video CD VCD ● Including SVCD (Conforming to IEC62107)
	DVD-RAM DVD-VR MP3 JPEG MPEG4 DivX ^{#1} ● DVD-VR Recorded with devices using Version 1.1 of the Video Recording Format (a unified video recording standard), such as DVD video recorders, DVD video cameras, personal computers, etc. ● JPEG Recorded with Panasonic SD multi cameras or DVD video recorders using the DCF (Design rule for Camera File system) Standard Version 1.0. ● MPEG4 Recorded with Panasonic SD multi cameras or DVD video recorders [conforming to SD VIDEO specifications (ASF standard)/MPEG4 (Simple Profile) video system/G.726 audio system].
	DVD-R (DVD-Video) ^{#2} / DVD-RW (DVD-Video) DVD-V ● Discs recorded and finalized ^{#3} on DVD video recorders or DVD video cameras. DVD-R (VR) ^{#2} / DVD-RW (VR) DVD-VR ● Discs recorded and finalized ^{#3} on DVD video recorders or DVD video cameras using Version 1.1 (or 1.2 DVD-R DL only) of the Video Recording Format (a unified video recording standard). DVD-R/DVD-RW MP3 JPEG MPEG4 DivX ^{#1} ● Finalize ^{#3} the disc after recording.
—	+R (Video) ^{#2} / +RW (Video) DVD-V ● Discs recorded and finalized ^{#3} on DVD video recorders or DVD video cameras.
	CD CD WMA MP3 JPEG VCD MPEG4 DivX ^{#1} ● This unit can play CD-R/RW recorded with the above formats. Close the sessions or finalize ^{#3} the disc after recording. ● CD This unit is compatible with HDCD, but does not support the Peak Extend function (a function which expands the dynamic range of high-level signals). HDCD-encoded CDs sound better because they are encoded with 20 bits, as compared with 16 bits for all other CDs. ● WMA MP3 JPEG This unit also plays HighMAT discs. ● WMA This unit does not support Multiple Bit Rate (MBR: a file that contains the same content encoded at several different bit rates).

^{#1} Functions added with DivX Ultra are not supported.

^{#2} Includes single-sided, double-layered discs.

^{#3} A process that allows play on compatible equipment.

● It may not be possible to play all the above-mentioned discs in some cases due to the type of disc or condition of the recording.

Discs that cannot be played

DVD-RW version 1.0, DVD-ROM, CD-ROM, CDV, CD-G, SACD and Photo CD, DVD-RAM that cannot be removed from their cartridge, 2.6-GB and 5.2-GB DVD-RAM, and "Chaoji VCD" available on the market including CVD, DVCD and SVCD that do not conform to IEC62107.

Video systems

- This unit can play PAL and NTSC, but your television must match the system used on the disc.
- PAL discs cannot be correctly viewed on an NTSC television.
- This unit can convert NTSC signals to PAL 60 for viewing on a PAL television (→ page 29, "NTSC Disc Output" in "Video" tab).

Disc caution

To clean discs

Wipe with a damp cloth and then wipe dry.

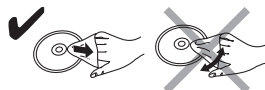

Disc handling precautions

- Do not attach labels or stickers to discs. This may cause disc warping, rendering it unusable.
- Do not write on the label side with a ball-point pen or other writing instrument.
- Do not use record cleaning sprays, benzene, thinner, liquids which prevent static electricity, or any other solvent.
- Do not use scratch-proof protectors or covers.
- Do not use the following discs:
 - Discs with exposed adhesive from removed stickers or labels (rented discs, etc).
 - Discs that are badly warped or cracked.
 - Irregularly shaped discs, such as heart shapes.

Maintenance

Clean this unit with a soft, dry cloth.

- Never use alcohol, paint thinner or benzene to clean this unit.
- Before using chemically treated cloth, carefully read the instructions that came with the cloth.

Do not use commercially available lens cleaners as they may cause malfunction. Cleaning of the lens is generally not necessary although this depends on the operating environment.

Before moving the unit, ensure the disc tray is empty. Failure to do so will risk severely damaging the disc and the unit.



Discs that can be played / Disc caution / Maintenance

Basic play

To display the picture from the main unit, turn on your television and change its video input mode (e.g. VIDEO 1, AV 1, etc.).

- To change your television's video input mode, refer to its operating instructions.

Using the main unit

The illustration shows SC-HT995.

1 Turn the unit on.



2 Select "DVD/CD".

- Select "TV" or "AUX" to enjoy video cassette recorder, television or cable TV programs. (Refer to page 14 for the necessary connections.)

SELECTOR



3 Open the disc tray.

OPEN/CLOSE



4 Load the disc.

- Load double-sided discs so the label for the side you want to play is facing up.
- For DVD-RAM, remove the disc from its cartridge before use.

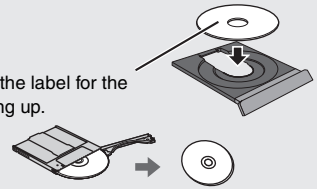

SURROUND ENHANCER
(→ page 35)

■ (Stop)



5 Start play.

The tray is automatically closed.

To change the sound quality → page 34



6 Adjust the volume.



Press to skip.
Press and hold to

- search during play
- start slow-motion play during pause (Motion picture part)
- Press [▶] (Play) to start normal play.



Note

- Discs continue to rotate while menus are displayed. To preserve the unit's motor and your television screen, press [■] (Stop) when you are finished with the menus.
- Total title number may not be displayed properly on +R/+RW.

Using the remote control

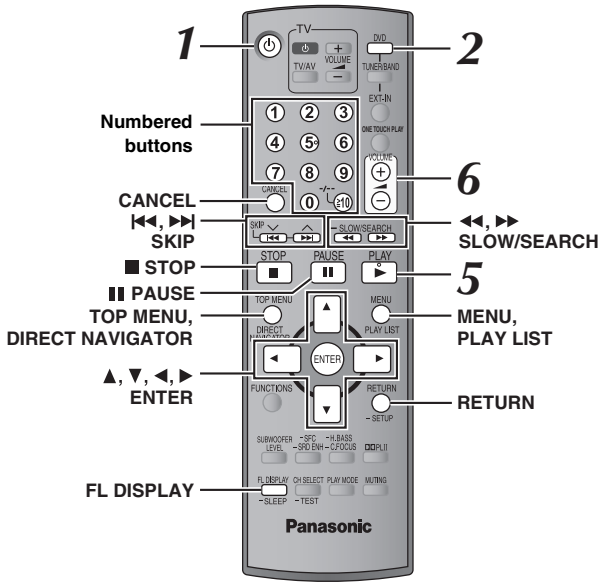

On-screen item select

Select
Register

Enter number

ENTER
CANCEL

DVD-VR **DVD-A** **DVD-V** **VCD** **CD**
e.g. To select 12:
[≧10] → [1] → [2]

VCD with playback control
Press [■ STOP] to cancel the PBC function, and then press the numbered buttons.

WMA **MP3** **JPEG** **MPEG4** **DivX**
e.g. To select 123:
[1] → [2] → [3] → [ENTER]

- Press [CANCEL] to cancel the number(s).

Stop

STOP

The position is memorized while "RESUME" is on the display.

- Press [▶ PLAY] to resume.
- Press [■ STOP] again to clear the position.

Pause

PAUSE

- Press [▶ PLAY] to restart play.

Skip

SKIP

- WMA** **MP3** **JPEG** **MPEG4** **DivX**
[This feature does not work during program and random play (→ page 20).]
- [▲, ▼]: **Group skip**
- [◀, ▶]: **Content skip**

Search (during play)

SLOW/SEARCH

- Up to 5 steps.
- Press [▶ PLAY] to start normal play.
- VCD** Slow-motion: forward direction only.
- MPEG4** **DivX** Slow-motion: Does not work.

Frame-by-frame (during pause)

ENTER

DVD-A (Motion picture part)
DVD-VR **DVD-V** **VCD**

- VCD** Forward direction only.

Disc menu

TOP MENU
DIRECT NAVIGATOR

DVD-A **DVD-V**
Shows a disc top menu.

DVD-VR
Press the button to show the programs (→ page 22).

Disc menu

MENU
PLAY LIST

DVD-V
Shows a disc menu.

DVD-VR
Press the button to show a playlist (→ page 22).

Return to previous screen

RETURN

VCD with playback control
Shows a disc menu.

Return to previous screen

RETURN

Main unit display

FL DISPLAY

DVD-VR **DVD-A** **DVD-V** **WMA** **MP3** **MPEG4** **DivX**
Time display
↔ Information display (e.g. **DVD-VR** Program number)

JPEG
When Slideshow (→ page 24) is on:
SLIDE ↔ Contents number
When Slideshow is off:
PLAY ↔ Contents number

Basic play

Convenient functions

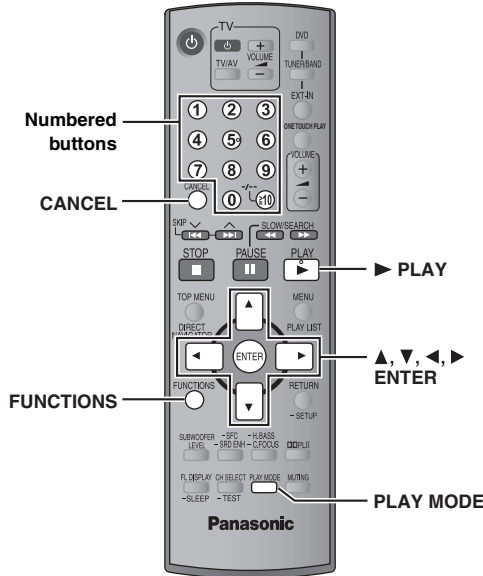

Displaying current playback condition

FUNCTIONS

Press [FUNCTIONS].

Each time you press the button:

Main menu (→ page 24) → Basics → Details
 ↑ off (No on-screen display) ↓

Basics

e.g. DVD-V

Current playback number Elapsed play time

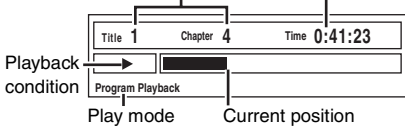

Details

e.g. DVD-V

Details-DVD-Video	
Audio information	Audio 1 ---DTS 3/2.1ch
Subtitle information	Subtitle - - -
Angle information	Angle 1/1
Aspect of current title	Source Aspect 4:3
Total play time of current title	Title Total Time 0:54:28

- [MPEG4] [DivX] Video and audio information is not displayed during search.

All group, Program and Random play

PLAY MODE

- Selecting "Play as Data Disc" in Other Menu (→ page 27) will be effective if the following functions are not available to play WMA, MP3, JPEG, MPEG4 or DivX video contents.
- [DVD-V] Some items cannot be played even if you have programmed them.
- [DVD-A] Some discs contain bonus groups. If a password screen appears after selecting a group, enter the password with the numbered buttons to play the bonus group. Refer also to the disc's jacket.

Press [PLAY MODE] while stopped.

All group, program and random playback screens appear sequentially.

All group ([DVD-A]) → Program → Random
 ↑ off (Normal play) ↓

To exit the all group, program and random mode
 Press [PLAY MODE] several times while stopped.

All group play

[DVD-A]

Press [▶] [PLAY].

All Group Playback

Press PLAY to start

Program play (up to 32 items)

1 Press the numbered buttons to select the item.

([WMA] [MP3] [JPEG] [MPEG4] [DivX]) Press [ENTER] to register the selection.)

e.g. DVD-V

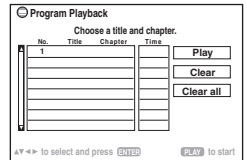

- Repeat this step to program other items.

- To select a 2-digit number

e.g. To select 12: [≥10] → [1] → [2]

[WMA] [MP3] [JPEG] [MPEG4] [DivX] [1] → [2] → [ENTER]

2 Press [▶] [PLAY].

To select an item using the cursor buttons

Press [ENTER] and [▲, ▼] to select an item, and then press [ENTER] again to register.

To select all the items

While the "Chapter", "Track" or "Content" field is highlighted, press [▲, ▼] to select "ALL". Then press [ENTER] again to register.

e.g. DVD-V

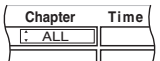

To change the selected program

1 Press [▲, ▼] to select the program number.

2 Press the numbered buttons to change each item.

([WMA] [MP3] [JPEG] [MPEG4] [DivX]) Press [ENTER] to register the selection.)

To clear the selected program

1 Press [▲, ▼] to select the program number.

2 Press [CANCEL] (or press [▲, ▼, ◀, ▶] to select "Clear" and press [ENTER]).

To clear the whole program

Select "Clear all" with [▲, ▼, ◀, ▶] and press [ENTER].

The whole program is also cleared when the disc tray is opened, the unit is turned off or another source is selected.

Random play

1 [DVD-A] [DVD-V] [WMA] [MP3] [JPEG] [MPEG4] [DivX]

Press the numbered buttons to select a group or title.

([WMA] [MP3] [JPEG] [MPEG4] [DivX]) Press [ENTER] to register the selection.)

e.g. DVD-V



[DVD-A]

- To enter all groups, press [◀, ▶] to select "All" and press [ENTER].

- To deselect a group, press numbered buttons corresponding to the group you want to clear.

2 Press [▶] [PLAY].

Playing data discs using navigation menus

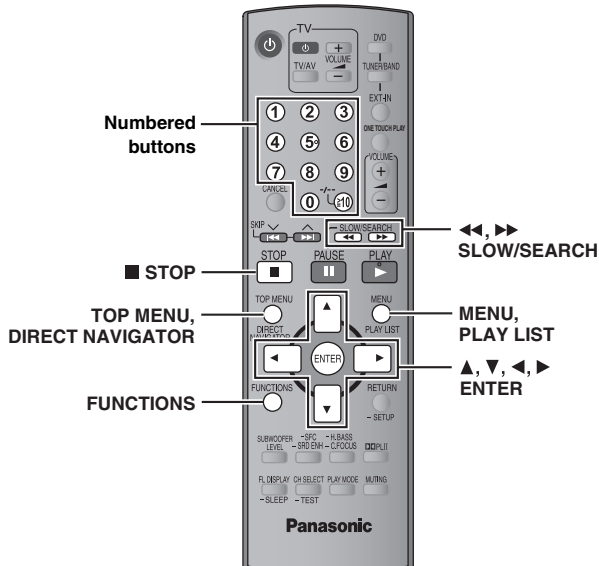

Using the submenu

- While Navigation Menu is displayed Press [FUNCTIONS].
- Press [▲, ▼] to select an item and press [ENTER].
Items shown differ depending on the type of disc.

Multi	Groups and contents are displayed.
List	Contents only
Tree	Groups only
Thumbnail	Thumbnail images [JPEG]
Next group	To go to next group
Previous group	To go to previous group
All	WMA/MP3, JPEG, MPEG4 and DivX video
Audio	WMA/MP3 only
Picture	JPEG only
Video	MPEG4 and DivX video only
Help display	To switch between guide messages and the elapsed play time indicator
Find	To search by content or group title (→ below)

Playing data discs

WMA MP3 JPEG MPEG4 DivX



Selecting "Play as Data Disc" in Other Menu (→ page 27) will be effective if the following functions are not available to play WMA, MP3, JPEG, MPEG4 or DivX video contents.

- Playing HighMAT™ discs (→ page 22)

Playing items in order (Playback Menu)

- Press [TOP MENU].
• To exit the screen, press [TOP MENU].

e.g.

Playback Menu		
All contents	All	Total 434
WMA/MP3	Audio	Total 7
JPEG	Picture	Total 427
MPEG4 and DivX video	Video	Total 2

A/V to select and press [ENTER]

- Press [▲, ▼] to select "All", "Audio", "Picture" or "Video" and press [ENTER].

Playing from the selected item (Navigation Menu)

- Press [MENU].
• To exit the screen, press [MENU].

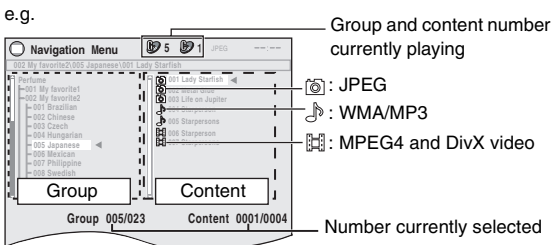

- Press [◀] followed by [▲, ▼] to select the group and press [ENTER].
- To play content in the group in order Press [ENTER].
To start play from the selected content Press [▲, ▼] to select and [ENTER].

Searching by a content or group title

Highlight a group title to search the group, or a content title to search its content.

- While the submenu is displayed (→ above) Press [▲, ▼] to select "Find" and press [ENTER].

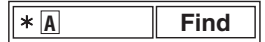

- Press [▲, ▼] to select a character and press [ENTER].
• Repeat to enter another character.
• Lower case characters are also searched.
• Press [◀, ▶] SLOW/SEARCH] to skip between A, E, I, O and U.
• Press [◀] to erase a character.
• Leave the asterisk (*) when you search for the titles including the character you enter.
• Erase the asterisk (*) to search for the titles starting with the character you enter. To add the asterisk (*) again, display the submenu again and select "Find".
- Press [▶] to select "Find" and press [ENTER].
The search result screen appears.
- Press [▲, ▼] to select the content or group and press [ENTER].

(Continued on next page)

To enjoy listening to WMA/MP3 contents while showing a JPEG image on the screen, select a JPEG file first and then select audio contents. (The opposite order is not effective.)

Selecting a track using CD text

CD

TOP MENU / MENU



Titles appear with CD Text disc playback.

1 Press [TOP MENU] or [MENU].

- To exit the screen, press [TOP MENU] or [MENU].

e.g. CD text

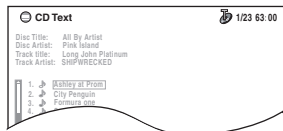

2 Press [▲, ▼] to select the track and press [ENTER].

- Press [FUNCTIONS] to show the playback condition and current position.

Playing HighMAT™ discs

WMA MP3 JPEG

TOP MENU / MENU



1 Press [TOP MENU].

- To exit the screen, press [■ STOP].
- To change the menu background to the one recorded on the disc, press [FUNCTIONS].

2 Press [▲, ▼, ◀, ▶] to select the item, and then press [ENTER].

- Repeat this step if necessary.

e.g.

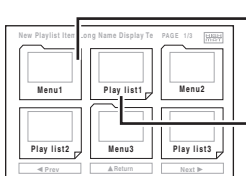

Menu: Takes you to the next menu which shows play lists or another menu

Playlist: play starts

Selecting from the list

1 During play

Press [MENU].

- To exit the screen, press [MENU].

e.g.

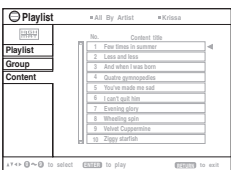

2 Press [◀] followed by [▲, ▼] to switch among "Playlist", "Group" and "Content" lists.

3 Press [▶] followed by [▲, ▼] to select an item and press [ENTER].

Playing RAM and DVD-R/-RW (DVD-VR) discs

DVD-VR

DIRECT NAVIGATOR / PLAY LIST

- Titles appear only if the titles are recorded on the disc.
- You cannot edit programs, playlists and disc titles.

Playing the programs

1 Press [DIRECT NAVIGATOR].

- To exit the screen, press [DIRECT NAVIGATOR].

e.g.

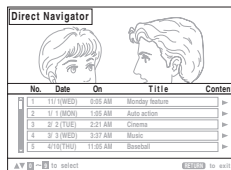

2 Press [▲, ▼] or the numbered buttons to select the program.

- To select a 2-digit number e.g. 12: [≥10] → [1] → [2]
- Press [▶] to show the contents of the program and the disc.

3 Press [ENTER].

Playing a playlist

This works only when the disc contains a play list.

1 Press [PLAY LIST].

- To exit the screen, press [PLAY LIST].

e.g.

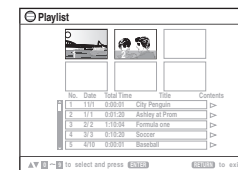

2 Press [▲, ▼] or the numbered buttons to select the playlist.

- To select a 2-digit number e.g. 12: [≥10] → [1] → [2]

3 Press [ENTER].

■ Playing scenes one by one

- While the playlist menu is displayed Press [▶].
- Press [▲, ▼] to select "Scene List" and press [ENTER].
 - "Contents" shows playlist information.
- Press [▲, ▼, ▶, ▶] to select a scene and press [ENTER].

Tips for making data discs

- When there are more than 8 groups, the eighth group onwards will be displayed on one vertical line in the menu screen.
- There may be differences in the display order on the menu screen and computer screen.
- This unit cannot play files recorded using packet write.

DVD-RAM

- Discs must conform to UDF 2.0.

DVD-R/RW

- Discs must conform to UDF bridge (UDF 1.02/ISO9660).
- This unit does not support multi-session. Only the default session is played.

CD-R/RW

- Discs must conform to ISO9660 level 1 or 2 (except for extended formats).
- This unit supports multi-session but if there are many sessions it takes more time for play to start. Keep the number of sessions to a minimum to avoid this.

Naming folders and files

(Files are treated as contents and folders are treated as groups on this unit.)

At the time of recording, prefix folder and file names. This should be with numbers that have an equal number of digits, and should be done in the order you want to play them (this may not work at times).

Files must have the extension (→ below).

WMA (Extension: “.WMA” or “.wma”)

- Compatible compression rate: between 48 kbps and 320 kbps
- You cannot play WMA files that are copy-protected.
- This unit does not support Multiple Bit Rate (MBR).

MP3 (Extension: “.MP3” or “.mp3”)

- Compatible compression rate: between 32 kbps and 320 kbps
- This unit does not support ID3 tags.
- Compatible sampling rates:
 - DVD-RAM, DVD-R/RW: 11.02, 12, 22.05, 24, 44.1 and 48 kHz
 - CD-R/RW: 8, 11.02, 12, 16, 22.05, 24, 32, 44.1 and 48 kHz

JPEG (Extension: “.JPG”, “.jpg”, “.JPEG” or “.jpeg”)

- JPEG files taken on a digital camera that conform to DCF Standard (Design rule for Camera File system) Version 1.0 are displayed. Files that have been altered, edited or saved with computer picture editing software may not be displayed.
- This unit cannot display moving pictures, MOTION JPEG and other such formats, and still pictures other than JPEG (e.g. TIFF), or play pictures with attached audio.

MPEG4 (Extension: “.ASF” or “.asf”)

- You can play MPEG4 data [conforming to SD VIDEO specifications (ASF standard)/MPEG4 (Simple Profile) video system/G.726 audio system] recorded with Panasonic SD multi cameras or DVD video recorders with this unit.
- The recording date may differ from that of the actual date.

DivX (Extension: “.DIVX”, “.divx”, “.AVI” or “.avi”)

- You can play all versions of DivX® video (including DivX®6) [DivX video system/MP3, Dolby Digital or MPEG audio system] with standard playback of DivX® media files. Functions added with DivX Ultra are not supported.
- GMC (Global Motion Compensation) is not supported.
- DivX files greater than 2 GB or have no index may not be played properly on this unit.
- This unit supports all resolutions up to maximum of 720 × 480 (NTSC)/720 × 576 (PAL).
- You can select up to 8 types of audio and subtitles on this unit.

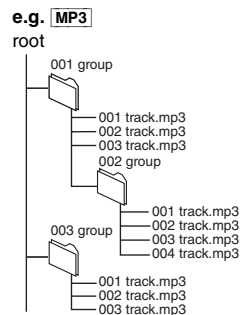

Using on-screen menus

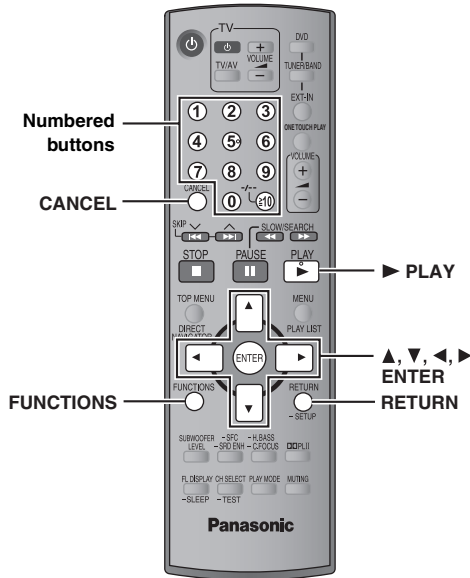

1	FUNCTIONS 	Show the Main menu.
2	Select Go to the next menu Register Return to the previous menu 	Select the menu. e.g. DVD-V
3	Select Register 1 2 3 4 5 6 7 8 9 0 10	Make the settings. e.g. DVD-V
4	RETURN 	Press to exit.

Main menu

Items shown differ depending on the type of disc.

Program Group Title Chapter Track Playlist Content	To start from a specific item e.g. DVD-VR To select Program 12 Press the numbered buttons: [1] → [2] → [ENTER]
---	--

Time	(Time Slip and Time Search do not work with +R/+RW discs.) To skip incrementally or decrementally (Time Slip for play only) 1 Press [ENTER] twice to show the Time Slip indicator. 2 Press [▲, ▼] to select the time and press [ENTER]. ● To change the steps more quickly, press and hold [▲, ▼]. To start from a specific time (Time Search) To change remaining/elapsed time display
Video	MPEG4 DivX To display pixel number DivX fps (frame per second) is also displayed.
Audio	DVD-A DVD-V DivX (with multiple soundtracks) To select audio soundtrack DVD-VR VCD DivX To select "L", "R" or "LR" DVD-V (Karaoke disc) To select "On" or "Off" for vocals ● Read the disc's instructions for details. Signal type/data LPCM/PPCM/Digital/DTS/MP3/MPEG: Signal type kHz (Sampling frequency)/bit/ch (Number of channels) e.g. 3/2 .1ch .1: Low frequency effect (not displayed if there is no signal) 0: No surround 1: Mono surround 2: Stereo surround (left/right) 1: Center 2: Front left+ Front right 3: Front left+ Front right+ Center ● DivX It may take some time for play to start if you change the audio on a DivX video disc.
	WMA MP3 To display the current bitrate or sampling frequency
Still Picture	To switch still pictures
Thumbnail	To show thumbnail images
Subtitle	DVD-V DivX (with multiple subtitles) VCD (SVCD only) To select subtitle language ● On +R/+RW, a subtitle number may be shown for subtitles that are not displayed. ● DVD-VR "On" or "Off" appears only with discs that contain subtitle on/off information (Subtitle on/off information cannot be recorded using Panasonic DVD Recorders).
Marker (VR)	DVD-VR To recall a marker recorded on DVD-Video recorders Press [▲, ▼] → Press [ENTER].
Angle	(with multiple angles) To select a video angle
Rotate Picture	To rotate a picture
Slideshow	To turn on/off slideshow On ↔ Off To change the slideshow timing 1 (Fast) to 5 (Slow)
Other Settings	(→ page 25)

Play Speed	<p>DVD-A (Motion picture part) DVD-VR DVD-V</p> <p>To change play speed – from “×0.6” to “×1.4”</p> <ul style="list-style-type: none"> ● Press [▶] PLAY] to return to normal play. ● After you change the speed <ul style="list-style-type: none"> – Dolby Pro Logic II and Sound Enhancement have no effect. – Audio output switches to 2-channel stereo. – Sampling frequency of 96 kHz is converted to 48 kHz. ● This function may not work depending on the disc's recording.
-------------------	---

■ **Play Menu**

This works only when the elapsed play time can be displayed. It also works with all JPEG content.

Repeat	<p>DVD-VR: Program→All→Off</p> <ul style="list-style-type: none"> ● During playlist play: Scene→Playlist→Off <p>DVD-A: Track→Group*→Off</p> <p>DVD-V: Chapter→Title*→Off</p> <p>VCD CD: Track→All→Off</p> <p>WMA MP3 MPEG4 DivX: Content→Group*→Off</p> <p>JPEG: Group*→Off</p> <p>*“All” is displayed during all group (DVD-A), program or random play.</p>
A-B Repeat	<p>Except JPEG DVD-VR (Still picture part) MPEG4 DivX</p> <p>To repeat a specified section Press [ENTER] at the starting and ending points. Press [ENTER] again to cancel.</p>
Marker	<p>Except DVD-VR</p> <p>To mark up to 5 positions to play again Press [ENTER] (The unit is now ready to accept markers.)</p> <p>To mark a position: Press [ENTER] (at the desired point).</p> <p>To mark another position: Press [◀, ▶] to select “*” → Press [ENTER].</p> <p>To recall a marker: Press [◀, ▶] → Press [ENTER].</p> <p>To erase a marker: Press [◀, ▶] → Press [CANCEL].</p> <ul style="list-style-type: none"> ● This feature does not work during program and random play. ● Markers you add are cleared when you open the disc tray or switch the unit to standby.
Advanced Disc Review	<p>DVD-VR (Except still picture part)</p> <p>DVD-V (Except +R/+RW)</p> <p>Allows you to browse the disc contents and start playing from the selected position. You can select either “Intro Mode” or “Interval Mode” in “Advanced Disc Review” in the “Disc” tab (→ page 28).</p> <p>When you find a title/program to play Press [▶] PLAY].</p> <ul style="list-style-type: none"> ● This may not work depending on the disc and the play position. ● DVD-VR This does not work when playing a playlist (→ page 22).

■ **Picture Menu**

Picture Mode	<p>Normal</p> <p>Cinema1: Mellows images and enhances detail in dark scenes.</p> <p>Cinema2: Sharpens images and enhances detail in dark scenes.</p> <p>Animation: Suitable for animation.</p> <p>Dynamic: Enhances the contrast for powerful images.</p> <p>User: Press [ENTER] to select “Picture Adjustment” (→ below).</p>
	<p>Picture Adjustment</p> <p>Contrast: Increases the contrast between light and dark parts of the picture.</p> <p>Brightness: Brightens the picture.</p> <p>Sharpness: Adjusts the sharpness of the edges of horizontal lines.</p> <p>Color (or Colour): Adjusts the shade of the picture's color.</p> <p>Gamma: Adjusts the brightness of dark parts.</p> <p>Depth Enhancer: Reduces the rough noise in the background to give a greater feeling of depth.</p>
Video Output Mode	<p>To select suitable picture quality with your television (Video recordings will be converted to, and output as, high-definition video.)</p> <p>When HDMI connection is being used and “Video Output” (→ page 30, “HDMI” tab) is set to “On”</p> <ul style="list-style-type: none"> *480p/576p/720p (progressive) *1080i (interlace) <ul style="list-style-type: none"> ● Select a video output with an “*” mark. The “*” mark shows that the video output is acceptable with your television. ● Selecting a video output without an “*” mark can result in the picture being distorted. If the picture is distorted, press and hold [CANCEL] until the picture is displayed correctly. (The output will return to “576p” or “480p”.) ● Output from the COMPONENT VIDEO OUT terminals will be “576p” or “480p”. <p>When HDMI connection is not being used and “Video Output” (→ page 30, “HDMI” tab) is set to “Off”</p> <ul style="list-style-type: none"> *480p/576p (progressive) *480i/576i (interlace) <p>When you select “xxx”p” (progressive) and a confirmation screen appears, select “Yes” only if connecting to a progressive output compatible television.</p> <p>* The numbers displayed depend on the disc being played. One of the above numbers is displayed.</p>



(Continued on next page)

Other Settings

Items shown differ depending on the type of disc.

Picture Menu (Continued)

<p>Transfer Mode</p>	<p>If you have chosen "xxx=p" (progressive) or "1080i" (interlace) (→ page 25, "Video Output Mode" in Picture Menu), select the method of conversion for progressive output to suit the type of material.</p> <ul style="list-style-type: none"> • The setting will return to Auto or Auto1 when the disc tray is opened, the unit is turned off or another source is selected. <p>When playing PAL discs, MPEG4 or DivX video contents</p> <p>Auto: Automatically detects the film and video content, and appropriately converts it.</p> <p>Video: Select when using Auto, and the content is distorted.</p> <p>Cinema: Select this if the edges of the film content appear jagged or rough when Auto is selected.  However, if the video content is distorted as shown in the illustration to the right, then select Auto.</p> <p>When playing NTSC discs</p> <p>Auto1: Automatically detects the film and video content, and appropriately converts it.</p> <p>Auto2: In addition to Auto1, automatically detects film contents with different frame rates and appropriately converts it.</p> <p>Video: Select when using Auto1 and Auto2, and the content is distorted.</p>
<p>Source Select DivX</p>	<p>When you select "Auto" the constructing method of the DivX contents is automatically distinguished and output. If the picture is distorted, select "I (Interlace)" or "P (Progressive)" depending on which constructing method was used when the contents were recorded to disc.</p> <p>Auto, I (Interlace), P (Progressive)</p>
<p>HD Picture Enhancer</p>	<p>This works when the HDMI connection is being used and "Video Output" (→ page 30, "HDMI" tab) is set to "On".</p> <p>To sharpen the "720p" and "1080i" picture quality Off ← 1 ← 2 ← 3 (sharpest picture) ↑ ↑ ↑</p>
<p>HDMI Color Space (or HDMI Colour Space)</p>	<p>This works when the HDMI connection is being used and "Video Output" (→ page 30, "HDMI" tab) is set to "On".</p> <p>To select suitable picture color with your television RGB YCbCr (4:4:4) YCbCr (4:2:2)</p> <ul style="list-style-type: none"> • If the setting above is not compatible with your television, it will not be displayed. • "RGB Range" (→ page 30, "HDMI" tab) is available when "RGB" is selected.

Audio Menu

<p>Dolby Pro Logic II</p>	<p>(→ page 34, Enhancing the stereo sound: Dolby Pro Logic II)</p>
<p>Dialogue Enhancer</p>	<p>To make the dialogue in movies easier to hear DVD-V (Dolby Digital, DTS, MPEG, 3-channel or higher, with the dialogue recorded in the center channel) DivX (Dolby Digital, 3-channel or higher, with the dialogue recorded in the center channel) On ↔ Off</p>
<p>Sound Enhancement</p>	<p>To enjoy comfortable, analog-like sound DVD-VR DVD-V (Discs recorded with 48 kHz only) WMA MP3 (Disc recording is other than 8 kHz, 16 kHz or 32 kHz) VCD CD On ↔ Off</p> <ul style="list-style-type: none"> • This may have no effect depending on the disc's recording. • This does not work with MP3 on DVD-RAM or DVD-R/RW.



■ **Display Menu**

Information	[JPEG] On ←→ Off
Subtitle Position	0 to -60 (in 2 unit steps)
Subtitle Brightness	Auto, 0 to -7
4:3 Aspect	<p>To select how to show images made for 4:3 aspect screens on a 16:9 aspect television</p> <p>Normal: Laterally stretches images.</p> <p>Auto: Expands 4:3 letterbox images to fill more of the screen. Other images appear in full in the center of the screen.</p> <p>Shrink: Images appear in the center of the screen.</p> <p>Zoom: Expands to 4:3 aspect ratio. If your television has a similar feature, use it instead for a better effect.</p>
Just Fit Zoom	<p>To select the appropriate screen size to fit your television screen</p> <p>[DVD-A] (Motion picture part) [DVD-VR] [DVD-V] [VCD]</p> <p>Auto, 4:3 Standard, European Vista, 16:9 Standard, American Vista, Cinemascope1, Cinemascope2</p> <p>e.g.</p> <p>[MPEG4] [DivX]</p> <p>Standard (×0.25 full-screen), Original (actual recorded size), Full (full-screen)</p> <ul style="list-style-type: none"> • This may not work depending on the discs recording.

Manual Zoom	<p>To zoom in and out manually</p> <ul style="list-style-type: none"> - in 0.01-unit steps from “×1.00” to “×1.60” - in 0.02-unit steps from “×1.60” to “×2.00” - in 0.05-unit steps from “×2.00” to “×4.00” ([MPEG4] [DivX] only) <ul style="list-style-type: none"> • To change the steps more quickly, press and hold [▲, ▼]. • [MPEG4] [DivX] It may not be possible to zoom up to “×4.00” depending upon the connected television and its settings.
Bit Rate Display	<p>[DVD-A] (Motion picture part) [DVD-VR] [DVD-V] [VCD] [MPEG4] [DivX]</p> <p>On ←→ Off</p>
GUI See-through	To make the on-screen menu transparent Off, On, Auto
GUI Brightness	To adjust the on-screen menu brightness -3 to +3
HDMI Status	Indicates various information when connected with HDMI AV OUT terminal. (→ below, Confirming HDMI information)

■ **Other Menu**

Setup	(→ page 28)
Play as DVD-Video or Play as DVD-Audio	To play DVD-Video contents of DVD-Audio Select “Play as DVD-Video”.
Play as DVD-VR, Play as HighMAT or Play as Data Disc	To use functions for data discs (→ page 21) (To play JPEG, MP3, MPEG4 or DivX video contents on DVD-RAM, or to play a HighMAT disc without using HighMAT function) Select “Play as Data Disc”.

■ **Confirming HDMI information**

■ HDMI Status—HDMI is connected.	Connection status
HDMI Information	
Audio Stream PCM	Shows the output signal type.
Max Channel 2ch	Shows the number of audio channels.
Video Format 480p/576p/720p/1080i	(→ page 25, Video Output Mode)
Color Space (or Colour Space) YCbCr (4:4:4)/YCbCr (4:2:2)/RGB	[→ page 26, HDMI Color Space (or HDMI Colour Space)]

■ **Note**

- All possible types of output are displayed.
- The current output for “Audio Stream”, “Video Format” and “Color Space (or Colour Space)” will be underlined.
(If you select a video output without an “*” mark in the “Video Output Mode” in Picture Menu, the selected video format will not be underlined.)
- When “Off” is selected in “Audio Output” (→ page 30, “HDMI” tab), “- - -” will be displayed in “Audio Stream” and “Max Channel”.



Changing the player settings

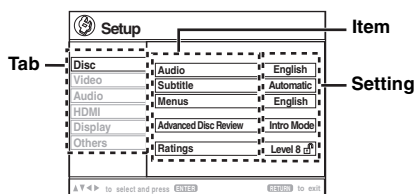
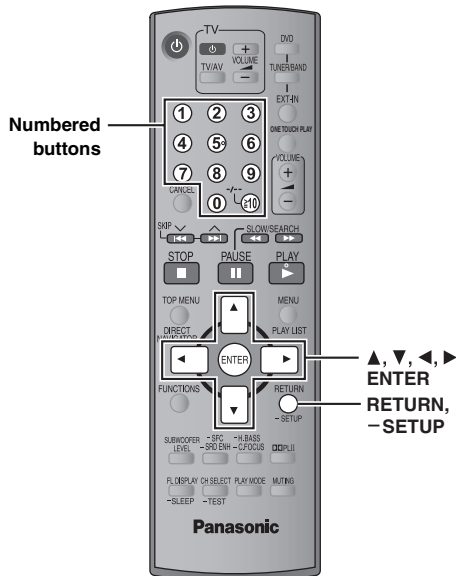

1		<p>Press and hold to show the Setup menu. If you have not performed QUICK SETUP (→ page 15), the QUICK SETUP screen appears.</p>
2		<p>Select the tab.</p>
3		<p>Select the item.</p>
4		<p>Make the settings.</p>
5		<p>Press repeatedly to exit.</p>

- The settings remain intact even if you switch the unit to standby.
- Underlined items are the factory settings in the following table.

QUICK SETUP enables successive settings of the items in the shaded area.

■ “Disc” tab

<p>Audio Choose the audio language.</p>	<p>• <u>English</u> • (Language options)^{#1} • Original^{#2} • Other****^{#3}</p>
<p>Subtitle Choose the subtitle language.</p>	<p>• <u>Automatic</u>^{#4} • English • (Language options)^{#1} • Other****^{#3}</p>
<p>Menus Choose the language for disc menus. Changing the menu language in QUICK SETUP also changes this setting.</p>	<p>• <u>English</u> • (Language options)^{#1} • Other****^{#3}</p>
<p>Advanced Disc Review (→ page 25)</p>	<p>• Intro Mode: Reviews each title/program. • Interval Mode: Reviews not only each title/program but also each 10-minute interval within a title/program.</p>
<p>Ratings Set a rating level to limit DVD-Video play.</p>	<p>Setting ratings (When level 8 is selected) • <u>8 No Limit</u> • 1 to 7 • 0 Lock All: To prevent play of discs without rating levels.</p> <p>When you select your ratings level, a password screen is shown. Follow the on-screen instructions. Do not forget your password. A message screen will be shown if a DVD-Video disc exceeding the rating level is inserted in the unit. Enter your password and then follow the on-screen instructions.</p>

^{#1} Language options

Southeast Asia and Thailand: Chinese

The Middle East, South Africa, Saudi Arabia, Kuwait, Australia and N.Z.: French, German, Italian, Spanish, Portuguese, Russian and Dutch



^{#2} The original language designated on the disc is selected.

^{#3} Input the appropriate code from the language code list (→ page 31).

^{#4} If the language selected for “Audio” is not available, subtitles appear in that language (if available on the disc).

QUICK SETUP enables successive settings of the items in the shaded area.

■ “Video” tab

TV Aspect Choose the setting to suit your television and preference.	<ul style="list-style-type: none"> ● 4:3 Pan&Scan: Regular aspect television (4:3) The sides of the widescreen picture are cut off so it fills the screen (unless prohibited by the disc). 	
	<ul style="list-style-type: none"> ● 4:3 Letterbox: Regular aspect television (4:3) Widescreen picture is shown in the letterbox style. 	
	<ul style="list-style-type: none"> ● 16:9: Widescreen television (16:9) 	
TV Type Select to suit the type of television.	<ul style="list-style-type: none"> ● Standard (Direct View TV) ● Projection TV 	<ul style="list-style-type: none"> ● CRT Projector ● Plasma TV ● LCD TV/Projector
Time Delay When connected with a Plasma display, adjust if you notice the audio is out of sync with the video.	<ul style="list-style-type: none"> ● 0ms ● 20ms ● 40ms ● 60ms ● 80ms ● 100ms 	
Still Mode Specify the type of picture shown when paused.	<ul style="list-style-type: none"> ● Automatic ● Field^{#5}: The picture is not blurred, but picture quality is lower. ● Frame^{#5}: Overall quality is high, but the picture may appear blurred. 	
NTSC Disc Output Choose PAL 60 or NTSC output when playing NTSC discs (→ page 17, Video systems).	<ul style="list-style-type: none"> ● PAL60: When connected to a PAL television. ● NTSC: When connected to an NTSC television. (The Middle East, South Africa, Saudi Arabia, Kuwait, Australia and N.Z.: “PAL60” is the factory preset.) 	
Picture/Video Output Change the video signal format to be output for JPEG, MPEG4 and DivX video if picture output is not smooth during playback.	<ul style="list-style-type: none"> ^{#6} ● NTSC/PAL60: Output will depend on “NTSC Disc Output” setting (→ above). <ul style="list-style-type: none"> ● PAL ^{#7} ● Automatic <ul style="list-style-type: none"> ● PAL ● NTSC/PAL60: Output will depend on “NTSC Disc Output” setting (→ above). 	

■ “Audio” tab

Dynamic Range Compression	<ul style="list-style-type: none"> ● Off ● On: Adjusts for clarity even when the volume is low by compressing the range of the lowest sound level and the highest sound level. Convenient for late night viewing. (Only works with Dolby Digital) 	
Speaker Settings (→ page 31) Set the delay time for your center and surround speakers.	<ul style="list-style-type: none"> ● Center: <u>0.0</u>/1.0/2.0/3.0/4.0/5.0 ms ● Surround (L/R): <u>0.0</u>/5.0/10.0/15.0 ms 	

^{#5} Refer to “Frame still and field still” (→ page 43, Glossary).

^{#6} **Southeast Asia and Thailand**

^{#7} **The Middle East, South Africa, Saudi Arabia, Kuwait, Australia and N.Z.**

(Continued on next page)

Changing the player settings

QUICK SETUP enables successive settings of the items in the shaded area.

■ “HDMI” tab

RGB Range Set “HDMI Color Space (or HDMI Colour Space)” to “RGB” (→ page 26, Picture Menu).	<ul style="list-style-type: none"> ● <u>Standard</u> ● Enhanced: When the black and white images are not distinct.
Video Output (This setting is irrelevant when connected through the VIDEO OUT or S-VIDEO OUT terminal.)	<ul style="list-style-type: none"> ● <u>On</u>: When connected through the HDMI AV OUT terminal. Video is output from the HDMI terminal. Video is also output from the COMPONENT VIDEO OUT terminal, but only in 480p or 576p (progressive). ● Off: When connected through the COMPONENT VIDEO OUT terminal. Video is not output from the HDMI AV OUT terminal, but from the COMPONENT VIDEO OUT terminal according to the setting of the “Video Output Mode” (→ page 25, Picture Menu).
Audio Output	<ul style="list-style-type: none"> ● <u>On</u>: When audio output is from the HDMI AV OUT terminal. (Depending on the capabilities of the connected equipment, audio output may differ from the audio settings of the main unit.) ● Off: When audio output is not from the HDMI AV OUT terminal. (The audio is output using the settings of the main unit.)
Control with HDMI (HDMI Control)	<ul style="list-style-type: none"> ● <u>On</u>: The HDMI Control function is available (→ page 39). ● Off

■ “Display” tab

Menu Language	*6 ● <u>English</u> ● 中文 *7 ● <u>English</u> ● Français ● Deutsch ● Italiano ● Español ● Português ● Русский ● Nederlands
On-Screen Messages	<ul style="list-style-type: none"> ● <u>On</u> ● Off
Background during Play Select background during JPEG, MPEG4 and DivX video playback.	*6 ● <u>Black</u> ● Gray *7 ● <u>Black</u> ● Grey

■ “Others” tab

FL Dimmer Change the brightness of the unit's display.	<ul style="list-style-type: none"> ● <u>Bright</u> ● Dim ● Auto: The display is dimmed, but brightens when you perform some operations.
DivX Registration Display the unit's registration code.	You need this registration code to purchase and play DivX Video-on-Demand (VOD) content (→ page 5, About DivX VOD content).
QUICK SETUP	<ul style="list-style-type: none"> ● <u>Yes</u> ● No
Re-initialize Setting *6 (or Re-initialise Setting *7) Return all values in the Setup menus to the default settings.	<ul style="list-style-type: none"> ● Yes: The password screen is shown if “Ratings” (→ page 28) is set. Please enter the same password. After “INIT” on the display disappears, turn the unit off and on again. ● <u>No</u>

*6 **Southeast Asia and Thailand**

*7 **The Middle East, South Africa, Saudi Arabia, Kuwait, Australia and N.Z.**

Changing the delay time of the speakers

(Effective when playing multi-channel audio)

(Center and surround speakers only)

For optimum listening with 5.1-channel sound, all the speakers, except for the subwoofer, should be the same distance from the seating position.

If you have to place the center or surround speakers closer to the seating position, adjust the delay time to make up for the difference.

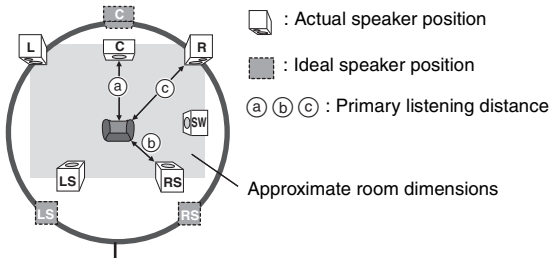

Circle of constant primary listening distance

If either distance a or b is less than c, find the difference in the table and change to the recommended setting.

a Center speaker		b Surround speaker	
Difference (Approx.)	Setting	Difference (Approx.)	Setting
30 cm	1.0 ms	150 cm	5.0 ms
60 cm	2.0 ms	300 cm	10.0 ms
90 cm	3.0 ms	450 cm	15.0 ms
120 cm	4.0 ms		
150 cm	5.0 ms		

- 1 Press [▲, ▼] to select the delay time box and press [ENTER].
- 2 Press [▲, ▼] to adjust the delay time and press [ENTER].

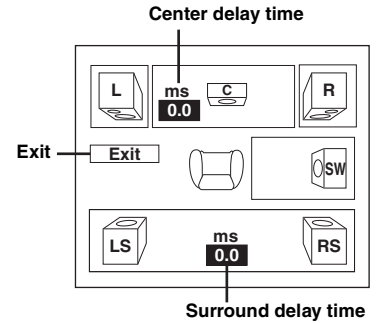

To finish the speaker setting

Press [◀] to select "Exit" and press [ENTER].

When you change the surround speaker setting for Dolby Digital, the setting also changes for Dolby Pro Logic II.

e.g., the settings for Music are the same as those for Dolby Digital.

Dolby Digital	Dolby Pro Logic II	
	Music	Movie
0 ms	0 ms	10 ms
5 ms	5 ms	15 ms
10 ms	10 ms	20 ms
15 ms	15 ms	25 ms

Language code list

Abkhazian: 6566	Danish: 6865	Italian: 7384	Norwegian: 7879	Swedish: 8386
Afar: 6565	Dutch: 7876	Japanese: 7465	Oriya: 7982	Tagalog: 8476
Afrikaans: 6570	English: 6978	Javanese: 7487	Pashto, Pushto: 8083	Tajik: 8471
Albanian: 8381	Esperanto: 6979	Kannada: 7578	Persian: 7065	Tamil: 8465
Ameharic: 6577	Estonian: 6984	Kashmiri: 7583	Polish: 8076	Tatar: 8484
Arabic: 6582	Faroese: 7079	Kazakh: 7575	Portuguese: 8084	Telugu: 8469
Armenian: 7289	Fiji: 7074	Kirghiz: 7589	Punjabi: 8065	Thai: 8472
Assamese: 6583	Finnish: 7073	Korean: 7579	Quechua: 8185	Tibetan: 6679
Aymara: 6589	French: 7082	Kurdish: 7585	Rhaeto-Romance: 8277	Tigrinya: 8473
Azerbaijani: 6590	Frisian: 7089	Laotian: 7679	Romanian: 8279	Tonga: 8479
Bashkir: 6665	Galician: 7176	Latin: 7665	Russian: 8285	Turkish: 8482
Basque: 6985	Georgian: 7565	Latvian, Lettish: 7686	Samoan: 8377	Turkmen: 8475
Bengali, Bangla: 6678	German: 6869	Lingala: 7678	Sanskrit: 8365	Twi: 8487
Bhutani: 6890	Greek: 6976	Lithuanian: 7684	Scots Gaelic: 7168	Ukrainian: 8575
Bihari: 6672	Greenlandic: 7576	Macedonian: 7775	Serbian: 8382	Urdu: 8582
Breton: 6682	Guarani: 7178	Malagasy: 7771	Serbo-Croatian: 8372	Uzbek: 8590
Bulgarian: 6671	Gujarati: 7185	Malay: 7783	Shona: 8378	Vietnamese: 8673
Burmese: 7789	Hausa: 7265	Malayalam: 7776	Sindhi: 8368	Volapük: 8679
Byelorussian: 6669	Hebrew: 7387	Maltese: 7784	Singhalese: 8373	Welsh: 6789
Cambodian: 7577	Hindi: 7273	Maori: 7773	Slovak: 8375	Wolof: 8779
Catalan: 6765	Hungarian: 7285	Marathi: 7782	Slovenian: 8376	Xhosa: 8872
Chinese: 9072	Icelandic: 7383	Moldavian: 7779	Somali: 8379	Yiddish: 7473
Corsican: 6779	Indonesian: 7378	Mongolian: 7778	Spanish: 6983	Yoruba: 8979
Croatian: 7282	Interlingua: 7365	Nauru: 7865	Sundanese: 8385	Zulu: 9085
Czech: 6783	Irish: 7165	Nepali: 7869	Swahili: 8387	

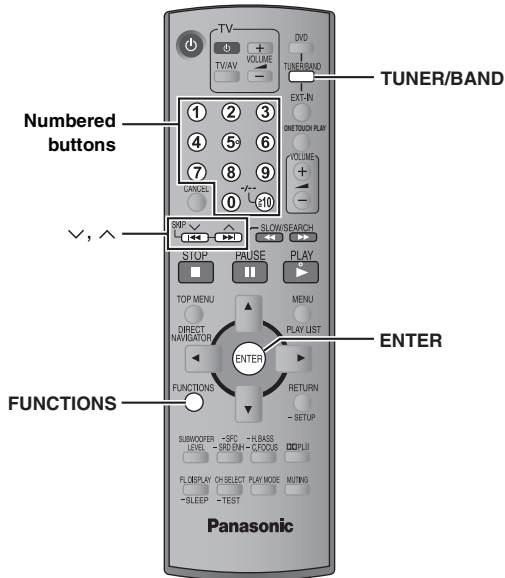

The illustration shows SC-HT995.

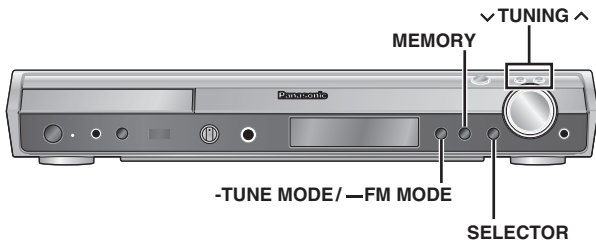

Presetting stations automatically

Main unit only

Up to 15 stations can be set in each band, FM and AM.

- 1 Press [SELECTOR] to select "FM" or "AM".
- 2 Press [-TUNE MODE] to select "MANUAL".
Each time you press the button: MANUAL ↔ PRESET
- 3 Press [∨ TUNING ∧] to tune to the lowest frequency (FM: 87.50, AM: 522 or 520).
Australia and N.Z.
(FM: 87.50, AM: 522)
- 4 Press and hold [MEMORY].
Release the button when "FM AUTO" or "AM AUTO" is displayed.

The tuner presets all the stations it can receive into the channels in ascending order.

- "SET OK" is displayed when the stations are set, and the radio tunes to the last preset station.
- "ERROR" is displayed when automatic presetting is unsuccessful. Preset the channels manually (→ right).

Selecting the preset channels

- 1 Press [TUNER/BAND] to select "FM" or "AM".
- 2 Press the numbered buttons to select the channel.

- To select a 2-digit number
e.g. 12: [≥10] → [1] → [2]

Alternatively, press [∨, ∧].

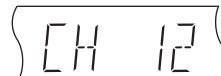

When a stereo FM broadcast is being received, "ST" lights in the display.

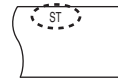

If noise is excessive

When "FM" is selected

Press and hold [—FM MODE] on the main unit to display "MONO".



Press and hold [—FM MODE] again to cancel the mode.

- The mode is also canceled when you change the frequency.

When "AM" is selected

Press [FUNCTIONS] on the remote control.

Each time you press the button: BP 2 ↔ BP 1

Manual tuning

Main unit only

- 1 Press [SELECTOR] to select "FM" or "AM".
- 2 Press [-TUNE MODE] to select "MANUAL".
- 3 Press [∨ TUNING ∧] to select the frequency.
• To start automatic tuning, press and hold [∨ TUNING ∧] until the frequency starts scrolling. Tuning stops when a station is found.

Presetting the channel

Up to 15 stations can be set in each band, FM and AM.

- ① While listening to the radio broadcast
Press [ENTER].
- ② While the frequency and "PGM" are flashing on the display
Press the numbered buttons to select a channel.

- To select a 2-digit number
e.g. To select 12:
[≥10] → [1] → [2]

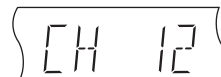

Alternatively, press [∨, ∧], and then press [ENTER].

The station occupying a channel is erased if another station is preset to that channel.

■ AM frequency step

Main unit only

Southeast Asia, Thailand, the Middle East, South Africa, Saudi Arabia and Kuwait

The step is factory-set to 9-kHz, but you can change it to receive broadcasts allocated in 10-kHz steps.

① Press [SELECTOR] to select "FM".

② Press and hold [SELECTOR].

After a few seconds the display changes to show the current minimum frequency. Continue to hold the button down. The minimum frequency changes and the step is changed.

To return to the original step, repeat steps ① and ②.

Note

After changing the setting, previously preset frequencies will be cleared. Preset them again.

Using an outdoor antenna (optional)

Use outdoor antennas if radio reception is poor.

- Disconnect the antenna when the unit is not in use.
- Do not use the outdoor antenna during an electrical storm.

The illustration shows SC-HT995.

FM outdoor antenna (Using a television antenna)

- Disconnect the FM indoor antenna.
- The antenna should be installed by a competent technician.

Leave the AM loop antenna connected.

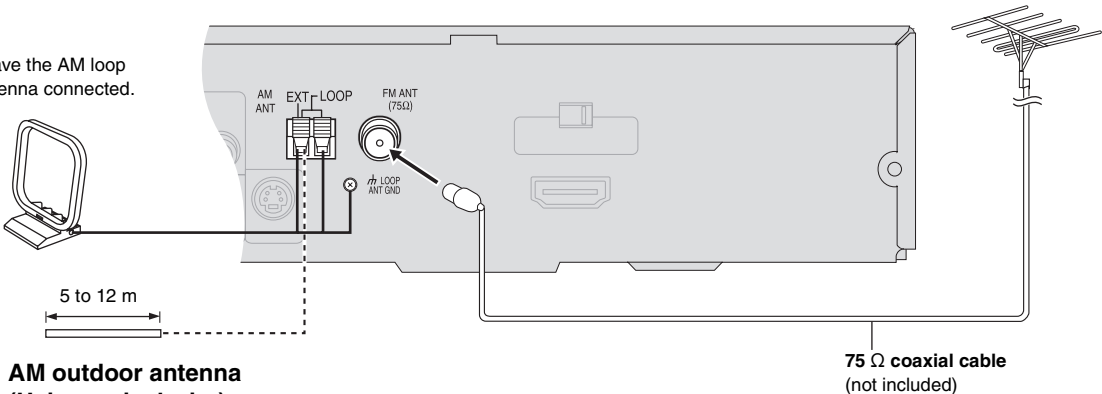

AM outdoor antenna (Using a vinyl wire)

Run a piece of vinyl wire horizontally across a window or other convenient location.



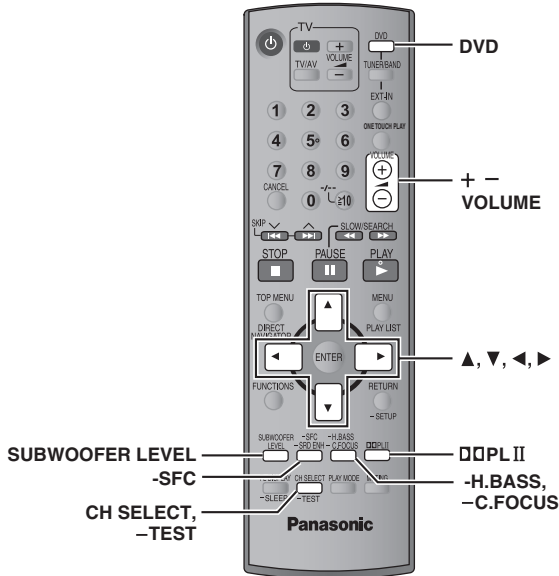

Enhancing the sound from the center speaker: Center Focus



This applies to discs where the dialogue is recorded in the center channel.

You can make the sound of the center speaker seem like it is coming from within the television.

Press and hold [-C.FOCUS].

Each time you press and hold the button:

C FOCUS ON \leftrightarrow C FOCUS OFF

- This does not work when Sound Field Control (MOVIE, SPORT or MUSIC) is turned on.
- This also works when Dolby Pro Logic II is turned on.

Enhancing the stereo sound: Dolby Pro Logic II



Except **[DivX]**

Dolby Pro Logic II is an advanced decoder that derives 5-channel surround (Left and Right Front, Center, Left and Right Surround) from stereo sound sources, whether or not it has been specifically Dolby Surround encoded.

Press [DOLBY II].

Each time you press the button:

Movie: Movie software, recorded in Dolby Surround.

Music: Stereo sources

Off: Cancel

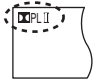

- This works only in DVD/CD or Digital In (**HT995W**) mode.
- "DOLBY II" lights when there is effect.
- This does not work when audio is output from HDMI AV OUT terminal.
- **HT995W** This does not work when "AUDIO L" or "AUDIO R" is selected in Audio Mode (\rightarrow page 38).

Changing the sound quality: Sound Field Control

-SFC

Press [-SFC].

Each time you press the button:

FLAT: Cancel (no effect is added) (factory preset).

MOVIE: Use this mode when playing movie software.

SPORT: Simulates sound to make you feel like you are at a sports event.

MUSIC: Adds surround effects to stereo sources.

HEAVY: Adds punch to rock.

CLEAR: Clarifies higher sounds.

SOFT: For background music.



- To check the current setting, press [-SFC].
- MOVIE, SPORT and MUSIC are not available when Dolby Pro Logic II is on, or when playing a disc recorded with a multi-channel source.
- You can adjust the volume of the surround speakers to get the best surround effect (\rightarrow page 35, Adjusting the volume of each speaker: Speaker level adjustments).
- When MOVIE, SPORT or MUSIC is turned on, you can enjoy audio from your television in 5.1-channel surround sound (\rightarrow page 38).

Adjusting the amount of bass: Subwoofer level

SUBWOOFER LEVEL

You can adjust the amount of bass. The unit automatically selects the most suitable setting according to the type of playback source.

Press [SUBWOOFER LEVEL].

• **[DVD-V]** **[DVD-VR]**
SUB W 4 (factory preset) \rightarrow SUB W 1 \rightarrow SUB W 2 \rightarrow SUB W 3

• **When another source is selected**

SUB W 2 (factory preset) \rightarrow SUB W 3 \rightarrow SUB W 4 \rightarrow SUB W 1

- To check the current setting, press [SUBWOOFER LEVEL].
- The setting you make is retained, and recalled every time you play the same type of source, except when Sound Field Control (MOVIE, SPORT or MUSIC) is turned on.

* When Sound Field Control (MOVIE, SPORT or MUSIC) is on, the factory presets are as follows:

- MOVIE: SUB W 4
- SPORT: SUB W 2
- MUSIC: SUB W 1

Enhancing the bass sound: H.BASS

-H.BASS



You can enhance low-frequency sound so that heavy bass sound can be heard clearly, even if the acoustics of your room are not optimal. The unit automatically selects the most suitable setting according to the type of playback source.

Press [-H.BASS].

● [DVD-V] [DVD-VR]

H.BASS ON (factory preset) ←→ H.BASS OFF

● When another source is selected

H.BASS OFF (factory preset) ←→ H.BASS ON



The setting you make is retained, and recalled every time you play from the same type of source.

Enhancing the surround sound effect: Surround Enhancer

-SRD ENH



Automatically adjusts each speaker to enhance the surround sound effect of multi-channel audio. When playing two-channel audio, the audio of the L/R front speakers is also output through the rest of the speakers creating a surround sound effect.

Press and hold [-SRD ENH].

Each time you press and hold the button:

SRD ENH ON ←→ SRD ENH OFF



Adjusting the volume of each speaker: Speaker level adjustments

CH SELECT



-TEST

This is one of the ways to get appropriate surround effects.

Preparation

Press [DVD].

- While stopped and no on-screen display is shown
Press and hold [-TEST] to output a test signal.
 - To stop the test signal, press and hold [-TEST] again.

L: Front left C: Center R: Front right
RS: Right surround LS: Left surround

 - There is no output from SW (subwoofer) channel.
- Press [VOLUME, +] or [-] to set the volume level normally used for listening.
- Press [▲] (increase) or [▼] (decrease) to adjust the speaker level for each speaker.
 - Adjust the speaker levels to the same level as the front speakers.

C, RS, LS: -6 dB to +6 dB

■ To adjust speaker level during play

[Effective when playing multi-channel audio or when Dolby Pro Logic II or Sound Field Control (MOVIE, SPORT or MUSIC) is on.]

① Press [CH SELECT] to select the speaker.

L → C → R → RS → LS → SW

↑

SW: Subwoofer

- You can adjust SW only if the disc includes a subwoofer channel.
 - "SW" does not appear on the display and is not adjustable when "DOLBY II" is lit.
 - "S" appears on the display when "MOVIE", "SPORT" or "MUSIC" is selected with Sound Field Control (→ page 34). In this case, you can adjust both surround speaker levels at the same time using [▲, ▼].
- S: -6 dB to +6 dB

② Press [▲] (increase) or [▼] (decrease) to adjust the speaker level for each speaker.

C, RS, LS, SW: -6 dB to +6 dB

(L, R: Only the balance is adjustable.)

- To adjust the balance of the front speakers, while "L" or "R" is selected, press [◀, ▶].



Using other useful functions

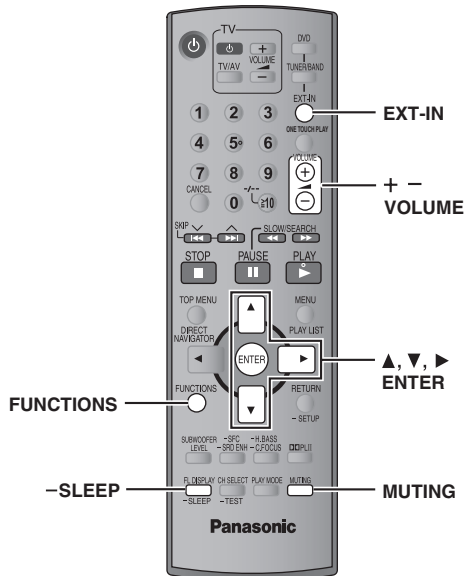

Using headphones

Main unit only

- 1 Reduce the volume and connect the headphones (not included).

Headphone plug type: Ø3.5 mm stereo mini plug

The illustration shows SC-HT995.



- 2 Adjust headphone volume with [VOLUME].
 - Audio is automatically switched to 2-channel stereo.

Note

To prevent hearing damage, avoid listening for prolonged periods of time.

Setting the sleep timer

—SLEEP

- 1 Press and hold [—SLEEP].

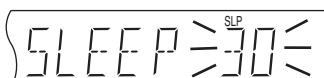

- 2 While the time is shown Press [—SLEEP] to select the time (in minutes).

SLEEP 30 → SLEEP 60 → SLEEP 90
 OFF ← SLEEP 120 ←

To cancel the timer

While the time is shown, press [—SLEEP] to select "OFF".

To confirm the remaining time

Press and hold [—SLEEP] again.

To change the setting

Repeat the procedure from the beginning.

Muting the sound

MUTING

Press [MUTING].

"MUTING" flashes on the unit's display.



To cancel

- Press [MUTING] again or reduce the volume to minimum "VOL 0", and then raise it to the required level.
- Muting is canceled when you switch the unit to standby.

Using the Music Port

The Music Port allows you to connect and enjoy music from an external device (e.g. MP3 player) through your home theater system.

Preparation

To avoid distorted sound, make sure that any equalizer function of your external device is turned off.

- 1 Reduce the volume and connect the external device (not included).

Plug type: Ø3.5 mm stereo mini plug

The illustration shows SC-HT995.

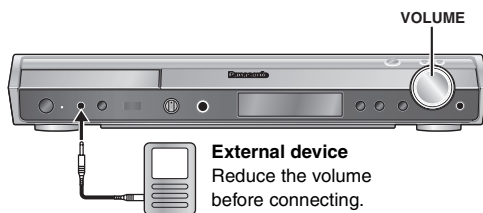

External device
Reduce the volume before connecting.

- 2 Press [EXT-IN] to select "MUSIC P."

HT995

MUSIC P. → TV
 AUX ←

HT995W

MUSIC P. → TV → AUX
 D-IN (Digital In) (→ page 38) ←



- 3 Adjust the external device volume to a normal listening level, and then adjust the volume of the main unit with [VOLUME].

• You can enjoy surround sound when you turn on Sound Field Control (MOVIE, SPORT or MUSIC) (→ page 34).

- 1 Turn [MIC LEVEL] to "MIN" and connect the microphone (not included).

Microphone plug type: \varnothing 6.3 mm monaural standard plug

The illustration shows SC-HT995.

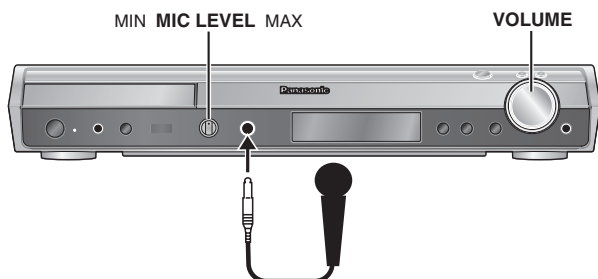

- 2 Insert the disc and start play (→ page 18)
- 3 Adjust the main volume with [VOLUME].
- 4 Adjust the microphone volume.

To turn the vocals on and off

DVD-V

- 1 Press [FUNCTIONS] during play.
- 2 Press [\blacktriangle , \blacktriangledown] to select "Audio" and press [\blacktriangleright].
- 3 Press [\blacktriangle , \blacktriangledown] to select "Karaoke" and press [\blacktriangleright].
- 4 Press [\blacktriangle , \blacktriangledown] to select the mode and press [ENTER].

Solo discs

Off: Vocals off
On: Vocals on

Duet discs

Off: Vocals off
V1+V2: Both parts
V1: Part 1 only
V2: Part 2 only

VCD

- 1 Press [FUNCTIONS] during play.
- 2 Press [\blacktriangle , \blacktriangledown] to select "Audio" and press [\blacktriangleright].
- 3 Press [\blacktriangle , \blacktriangledown] to select the mode and press [ENTER].

LR: Vocals and accompaniment

L: Accompaniment only

R: Vocals only

Select "L" for karaoke. (R and L may be reversed on some discs.)



Operating other equipment

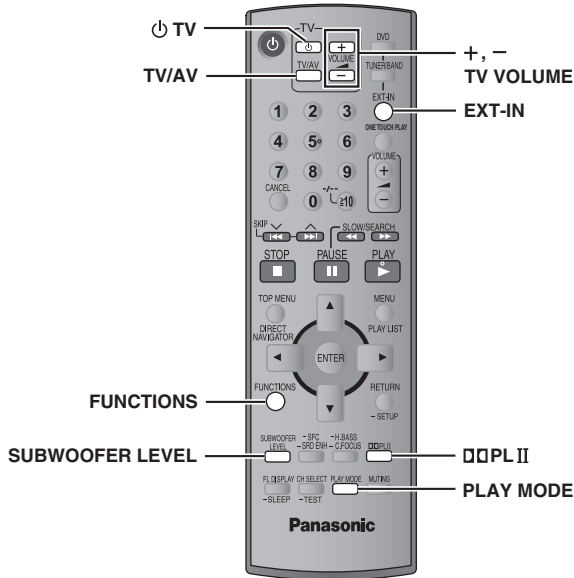

HT995W Operating the cable TV box, digital broadcasting or satellite receiver

This unit can decode the surround signals received through cable TV box, digital broadcasting or satellite broadcasts. Refer to your equipment's operating instructions for details. Only Dolby Digital and PCM can be played with this connection.

Back of the main unit

To DIGITAL OUT

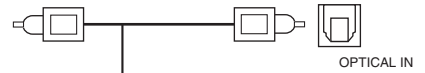

Optical digital audio cable (not included)
 • Do not bend sharply when connecting.

Press [EXT-IN] several times to select "D-IN" (Digital In) as the source.

• Main unit: Press [SELECTOR] several times.

When you select "D-IN" as the source, you can select the following sound effects. (These functions only work with Dolby Digital or PCM, excluding Audio Mode, which only works with Dolby Digital Dual Mono.)

PCM FIX Mode

Press and hold [FUNCTIONS].

PFIX ON: Select when receiving only PCM signals.

PFIX OFF (factory preset): Select when receiving Dolby Digital and PCM signals.

Dynamic Range Compression

Press and hold [SUBWOOFER LEVEL].

DRC ON: Adjusts for clarity even when the volume is low by compressing the range of the lowest sound level and the highest sound level. Convenient for late night viewing. (Only works with Dolby Digital)

DRC OFF (factory preset)

Audio Mode

Press and hold [PLAY MODE].

AUDIO ST, AUDIO L, AUDIO R ("AUDIO L" and "AUDIO R" only appear when the signal is Dolby Digital Dual Mono.)

Dolby Pro Logic II (→ page 34)

Press [DOLBY II].

Note

Audio that is input through the OPTICAL IN terminal cannot be output through the HDMI terminal.

Operating the television

You can use the remote control to operate a Panasonic television. Connect your equipment referring to "Cable TV box or video cassette recorder connection" (→ page 14).

Note

The remote control may not work properly with some models.

Aim the remote control at the television.

Turning the television on/off

Press [TV].

Switching the television's video input mode

Press [TV/AV].

Adjusting the volume

Press [+ , - TV VOLUME].

To play audio from your television through your home theater system

Press [EXT-IN] to select "TV" or "AUX" as the source, reduce the volume on the television to its minimum, and control the volume on the main unit. Each time you press the button:

HT995

MUSIC P. → TV
 ↑ AUX ←

HT995W

MUSIC P. → TV → AUX
 ↑ D-IN (Digital In) (→ right) ←

• You can enjoy 5.1-channel surround sound when you turn on Sound Field Control (MOVIE, SPORT or MUSIC) (→ page 34).

Operating both the television and the home theater system: Control with HDMI (HDAVI Control™)

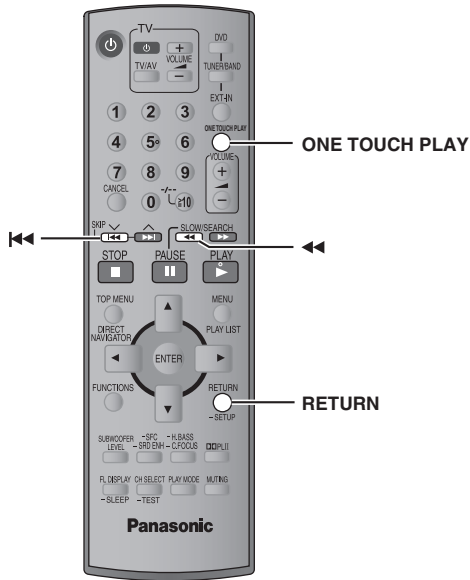

What is HDAVI Control?

HDAVI Control is a convenient function that offers linked operation of this unit and Panasonic TV (VIERA) with HDAVI Control. You can use this function by connecting the equipment with the HDMI cable. For operational details, see the operating instructions of the connected equipment.

Preparation

- Confirm that the HDMI connection (→ page 13) has been made.
- Set “Control with HDMI” (HDAVI Control) to “On” (→ page 30, “HDMI” tab).
- To complete and activate the connection correctly, turn on all HDAVI Control compatible equipment and select the input channel corresponding to the home theater on the television.

Whenever the connection or settings are changed, reconfirm the points above.

One Touch Play

You can turn on the main unit and television, and start playing the disc in the play position with a single press of a button.

Press [ONE TOUCH PLAY].

Note

Playback may not be immediately displayed on the television. If you miss the beginning portion of playback, press [◀◀] or [◀] to go back to where playback started.

Automatic input switching

When the following operation is performed the television will automatically switch the input channel and display the corresponding action.

- When play starts on the unit

Theater speaker

You can select whether audio is output from the home theater system or the television by using the television settings. For details, refer to the operating instructions of your television.

When audio is output from the home theater speakers

- The television speakers are automatically muted.
- You can control the volume setting using the volume or mute button on the television remote control. (The volume level is displayed on the main unit’s FL display.)
- If you turn off the home theater system, speakers automatically switch to the television.

When audio is output from the television speakers

- The volume of the home theater system is set to “0”.
- Audio output is 2-channel audio.

- To cancel muting, you can also use the home theater remote control (→ page 36, Muting the sound).
- When switching between the home theater system and television speakers, the TV screen may be blank for several seconds.
- **HT995W** When you switch the audio output from the television speakers to the home theater speakers, the main unit automatically switches its input source to either “TV” or “D-IN”.

To toggle which input source the main unit will automatically switch to, press and hold [RETURN] while the main unit is in “TV” or “D-IN” mode.

- The default setting is “TV”.
- Changing this setting also affects the power off link function (→ below).
- Depending on the television input source, the main unit may not automatically switch its input source. For more details, refer to the operating instructions of your television.

Power off link

When the television is turned off, the home theater system goes into standby mode automatically.

HT995

- This function works only when “DVD/CD” or “TV” is selected as the source on the home theater system.
- When the television is turned on, the home theater system does not turn on automatically. (Power on link is not available.)

HT995W

- This function works only when “DVD/CD”, “TV”^{*} or “D-IN”^{*} is selected as the source on the home theater system.
- When the television is turned on, the home theater system does not turn on automatically. (Power on link is not available.)

^{*} For “TV” or “D-IN” mode, power off link can be set to work with one or the other.

To toggle the mode that this function works with, press and hold [RETURN] while the main unit is in “TV” or “D-IN” mode.

- The default setting is “TV”.
- Changing this setting also affects the theater speaker function (→ above).



Troubleshooting guide

Before requesting service, make the following checks. If you are in doubt about some of the check points, or if the solutions indicated in the table do not solve the problem, consult your dealer for instructions.

Power		Page
No power.	<ul style="list-style-type: none"> Insert the AC mains lead securely. 	14
The unit is automatically switched to standby mode.	<ul style="list-style-type: none"> The Sleep timer was working and had reached the set time limit. 	36

Unresponsive or inoperable function

No response when any buttons are pressed.	<ul style="list-style-type: none"> This unit cannot play discs other than the ones listed in these operating instructions. The unit may not be operating properly due to lightning, static electricity or some other external factor. Turn the unit off and then back on. Alternatively, turn the unit off, disconnect the AC mains lead, and then reconnect it. Condensation has formed. Wait 1 to 2 hours for it to evaporate. 	17 — —
No response when remote control buttons are pressed.	<ul style="list-style-type: none"> Check that the batteries are installed correctly. The batteries are depleted. Replace them with new ones. Aim the remote control at the remote control signal sensor and operate. 	15 15 16
No picture or sound.	<ul style="list-style-type: none"> Check the video or speaker connection. Check the power or input setting of the connected equipment and the main unit. Check that the disc has something recorded on it. 	6, 7, 11, 13, 14 — —
You have forgotten your ratings password. Reset all the settings to Factory Preset.	<ul style="list-style-type: none"> While stopped and "DVD/CD" is the source, press and hold [■] (Stop) on the main unit and [≥10] on the remote control until "Initialized" (or "Initialised") disappears from the television. Turn the unit off and on again. All settings will return to the default values. 	—
The HDAVI Control function does not respond.	<ul style="list-style-type: none"> Depending on the condition of the home theater system or the connected equipment, it may be necessary to repeat the same operation so that the function can work correctly. 	39

Specific operation undesirable or unexpected

It takes time before play starts.	<ul style="list-style-type: none"> Play may take time to begin when an MP3 track has still picture data. Even after the track starts, the correct play time will not be displayed. This is normal. [MP3] This is normal on DivX video. [DivX] 	— —
Folders on a data CD are not displayed correctly. [WMA] [MP3] [JPEG] [MPEG4] [DivX]	<ul style="list-style-type: none"> Folders deeper than the eighth layer are displayed as the eighth layer. 	—
A menu screen appears during skip or search. [VCD]	<ul style="list-style-type: none"> This is normal for Video CDs. 	—
Playback control menu does not appear. [VCD] with playback control	<ul style="list-style-type: none"> Press [■ STOP] twice and then press [▶ PLAY]. 	—
Program and Random play do not work. [DVD-V]	<ul style="list-style-type: none"> These functions do not work with some DVD-Videos. 	—
Selecting audio soundtrack "2" does not change the audio. [DVD-A]	<ul style="list-style-type: none"> Even if a second soundtrack is not recorded, two numbers are normally shown. 	—
Play does not start.	<ul style="list-style-type: none"> This unit may not play WMA and MPEG4 that contains still picture data. If playing DivX VOD content, refer to the homepage where you purchased the DivX VOD content. (Example: www.divx.com/vod) [DivX] If a disc contains CD-DA and other formats, proper playback may not be possible. 	— — —
Play restarts from the beginning when the soundtrack is changed. [DVD-A]	<ul style="list-style-type: none"> This is normal for DVD-Audio. 	—

Subtitle

Subtitle position is wrong.	<ul style="list-style-type: none"> Adjust the position. ("Subtitle Position" in Display Menu) 	27
No subtitles.	<ul style="list-style-type: none"> Display the subtitles. ("Subtitle" in Main menu) Subtitles may not be displayed depending on the disc. [DivX] 	24 —



Marker		Page
Cannot add markers.	<ul style="list-style-type: none"> You cannot add markers with DVD-RAM or DVD-R/-RW (DVD-VR) discs. If the disc's elapsed play time does not appear on the unit's display, you cannot add markers. 	—

A-B repeat

Point B is automatically set.	<ul style="list-style-type: none"> The end of an item becomes point B when it is reached. 	—
-------------------------------	--	---

Sound abnormal or improper

Sound is distorted.	<ul style="list-style-type: none"> Noise may occur when playing WMA. When using the HDMI output, audio may not be output from other terminals. 	—
Effects do not work.	<ul style="list-style-type: none"> Some audio effects do not work or have less effect with some discs. 	—
Humming is heard during play.	<ul style="list-style-type: none"> An AC mains lead or fluorescent light is near the main unit. Keep other appliances and cables away from the main unit (and wireless system [HT995W]). 	—
No sound.	<ul style="list-style-type: none"> There may be a slight pause in sound when you change the play speed. Audio may not be output due to how files were created. [DivX] [HT995W] Ensure that the wireless system is connected to the mains socket, and "[W]" is displayed on the main unit's display. Audio may not be heard when more than 4 devices are connected with HDMI cables. Reduce the number of connected devices. When using the HDMI connection, ensure that "Audio Output" in the "HDMI" tab is set to "On". 	<p>—</p> <p>14, 16</p> <p>—</p> <p>30</p>

Menus

The Setup menu cannot be accessed.	<ul style="list-style-type: none"> Select "DVD/CD" as the source. Cancel All group, Program and Random play. 	<p>—</p> <p>20</p>
------------------------------------	--	--------------------

Picture abnormal or unviewable

The picture on the television is not displayed correctly or disappears.	<ul style="list-style-type: none"> The unit and television are using different video systems. <ul style="list-style-type: none"> [Southeast Asia and Thailand] Use a multi-system or NTSC television. [Others] Use a multi-system or PAL television. The system used on the disc does not match your television. <ul style="list-style-type: none"> PAL discs cannot be correctly viewed on an NTSC television. This unit can convert NTSC signals to PAL 60 for viewing on a PAL television ("NTSC Disc Output" in "Video" tab). Ensure that the unit is connected directly to the television, and is not connected through a video cassette recorder. Mobile telephone chargers can cause some disturbance. If you are using an indoor television antenna, change to an outdoor antenna. The television antenna wire is too close to the unit. Move it away from the unit. Change "Source Select" in Picture Menu. [DivX] Picture may not be seen when more than 4 devices are connected with HDMI cables. Reduce the number of connected devices. When using HDMI output, the video signal is progressive. Use other video connections if your television is not compatible with progressive video. If the picture is distorted or not displayed when using HDMI output, press and hold [CANCEL] until the picture is displayed correctly. (The output will return to "480p" or "576p".) 	<p>—</p> <p>—</p> <p>29</p> <p>13, 14</p> <p>—</p> <p>—</p> <p>—</p> <p>26</p> <p>—</p> <p>13, 14</p> <p>—</p>
Picture size does not fit the screen.	<ul style="list-style-type: none"> Change "TV Aspect" in the "Video" tab. Use the television to change the aspect. If your television does not have that function, change "4:3 Aspect" in Display Menu. Change the zoom setting. ("Just Fit Zoom" or "Manual Zoom" in Display Menu) 	<p>29</p> <p>27</p> <p>27</p>
Picture stops. [DivX]	<ul style="list-style-type: none"> Picture may stop if the DivX files are greater than 2 GB. 	—
Menu is not displayed correctly.	<ul style="list-style-type: none"> Restore the zoom ratio to "× 1.00". ("Manual Zoom" in Display Menu) Set "Subtitle Position" in Display Menu to "0". Set "4:3 Aspect" in Display Menu to "Normal". 	<p>27</p> <p>27</p> <p>27</p>
Auto zoom function does not work well.	<ul style="list-style-type: none"> Turn off television zoom function. Use the other preset aspect ratios or manual adjustment. Zoom function may not work well, especially in dark scenes and may not work depending on the type of disc. 	<p>—</p> <p>27</p> <p>—</p>
When playing PAL disc, picture distorted.	<ul style="list-style-type: none"> Set "Transfer Mode" in Picture Menu to "Auto". 	26

(Continued on next page)



Progressive video		Page
There is ghosting when progressive or HDMI output is on.	<ul style="list-style-type: none"> This problem is caused by the editing method or material used on DVD-Video, but should be corrected if you use interlaced output. Set "Video Output Mode" in Picture Menu to "480i" or "576i". (Alternatively, press and hold [CANCEL] to switch to "480i" or "576i".) Disable the HDMI AV OUT connection and use other video connections. Make the settings in the following order: <ol style="list-style-type: none"> Set "Video Output" in the "HDMI" tab to "Off". Set "Video Output Mode" in Picture Menu to "480i" or "576i". (Alternatively, press and hold [CANCEL] to switch to "480i" or "576i".) 	25
		25, 30
Pictures not in progressive output.	<ul style="list-style-type: none"> Select "480p" or "576p" in "Video Output Mode" in Picture Menu. The unit's VIDEO OUT or S-VIDEO OUT terminal outputs the interlaced signal even if "PRG" is displayed. 	25 13, 14

Listening to the radio

Distorted sound or noise is heard. "ST" flickers or does not light.	<ul style="list-style-type: none"> Adjust the position of the FM or AM antenna. Use an outdoor antenna. 	— 33
A beat sound is heard.	<ul style="list-style-type: none"> Turn the television off or move it away from the unit. 	—
A low hum is heard during AM broadcasts.	<ul style="list-style-type: none"> Separate the antenna from other cables. 	—

Unit displays

The display is dark.	<ul style="list-style-type: none"> Select "Bright" in "FL Dimmer" in the "Others" tab. 	30
"NO PLAY"	<ul style="list-style-type: none"> You inserted a disc the unit cannot play; insert one it can. You inserted a blank disc. You inserted a disc that has not been finalized. 	17 — —
"NO DISC"	<ul style="list-style-type: none"> You have not inserted a disc; insert one. You have not inserted the disc correctly; insert it correctly. 	— 18
"F61"	<ul style="list-style-type: none"> Check and correct the speaker cable connections. If this does not fix the problem, consult the dealer. 	6, 7, 11
"DVD U11"	<ul style="list-style-type: none"> Disc may be dirty. Wipe it clean. 	17
"ERROR"	<ul style="list-style-type: none"> Incorrect operation performed. Read the instructions and try again. 	—
"DVD H□□"	<ul style="list-style-type: none"> Trouble may have occurred. The numbers following "H" and "F" depend on the status of the unit. Turn the unit off and then back on. Alternatively, turn the unit off, disconnect the AC mains lead, and then reconnect it. 	—
"DVD F□□□"	<ul style="list-style-type: none"> If the service numbers fail to clear, note the service number and contact a qualified service person. 	—
□ stands for a number.		
HT995W		
"W" is flashing.	<ul style="list-style-type: none"> There is no link between the main unit and the wireless accessory. Check that the wireless accessory is plugged into the mains socket. Ensure that the digital transceiver is fully inserted into the slot of the main unit. 	— —
"D.MIX" is flashing. DVD-A	<ul style="list-style-type: none"> Down-mixing is the process of remixing the multiple-channel audio found on some discs into two channels. The disc contains single-channel or multiple-channel signals which may not be reproduced authentically. 	—
"U701"	<ul style="list-style-type: none"> The connected equipment is not HDMI-compatible. 	—
"U70□"	<ul style="list-style-type: none"> The HDMI connection acts unusually. <ul style="list-style-type: none"> The connected equipment is not HDMI-compatible. The HDMI cable is too long. The HDMI cable is damaged. 	— — — —
□ stands for a number.		
The actual number following "U70" will depend on the state of the main unit.		

Television displays

"⊘"	<ul style="list-style-type: none"> The operation is prohibited by the unit or disc. 	—
"Cannot play group xx, content xx" "Cannot display group xx, content xx"	<ul style="list-style-type: none"> You are trying to display incompatible group or content. 	—
"This disc may not be played in your region"	<ul style="list-style-type: none"> Only DVD-Video discs that include or have the same region number as the one on the rear panel of this unit can be played. 	Cover page
No on-screen display.	<ul style="list-style-type: none"> Select "On" in "On-Screen Messages" in the "Display" tab. 	30
"Group xx content xx is protected"	<ul style="list-style-type: none"> You are trying to play protected group or content. You cannot play it. 	—
"Check the disc"	<ul style="list-style-type: none"> This disc may be dirty. 	17
"Authorization Error" DivX	<ul style="list-style-type: none"> You are trying to play the DivX VOD content that was purchased with a different registration code. You cannot play the content on this unit. 	5
Southeast Asia and Thailand		
"Rental Expired" DivX	<ul style="list-style-type: none"> The DivX VOD content has zero remaining plays. You cannot play it. 	5
Others		
"Rented Movie Expired" DivX		
"Due to copyright protection, audio cannot be output from HDMI" DVD-A	<ul style="list-style-type: none"> If you connect to equipment that does not support CPPM (→ page 43, Glossary), audio from a CPPM copy-protected DVD-Audio disc cannot be output from the HDMI AV OUT terminal. 	—
Main unit's screen saver remains.	<ul style="list-style-type: none"> When using the HDMI connection, audio/video information is continually transferred between the main unit and the television regardless of which source has been selected on the main unit. This is normal. 	—



CPPM (Content Protection for Prerecorded Media)

A copy protection system used for DVD-Audio files. This unit supports CPPM.

Decoder

A decoder restores the coded audio signals on DVDs to normal. This is called decoding.

DivX

DivX is a popular media technology created by DivX, Inc. DivX media files contain highly compressed video with high visual quality that maintains a relatively small file size.

Dolby Digital

This is a method of coding digital signals developed by Dolby Laboratories. Apart from stereo (2-channel) audio, these signals can also be multi-channel audio. A large amount of audio information can be recorded on one disc using this method.

DTS (Digital Theater Systems)

This surround system is used in many movie theaters around the world. There is good separation between the channels, so realistic sound effects are possible.

Dynamic range

Dynamic range is the difference between the lowest level of sound that can be heard above the noise of the equipment and the highest level of sound before distortion occurs.

Film and video

DVD-Videos are recorded using either film or video. This unit can determine which type has been used, then uses the most suitable method of progressive output.

Film: Recorded at 25 frames per second (PAL discs) or 24 frames per second (NTSC discs). (NTSC discs recorded at 30 frames per second as well).
Generally appropriate for motion picture films.

Video: Recorded at 25 frames/50 fields per second (PAL discs) or 30 frames/60 fields per second (NTSC discs). Generally appropriate for TV drama programs or animation.

Frame still and field still

Frames are the still pictures that go together to make a moving picture. There are about 30 frames shown each second.

One frame is made up of two fields. A regular television shows these fields one after the other to create frames.

A still is shown when you pause a moving picture. A frame still is made up of two alternating fields, so the picture may appear blurred, but overall quality is high.

A field still is not blurred, but it has only half the information of a frame still so picture quality is lower.

HDMI (High-Definition Multimedia Interface)

HDMI is a next-generation digital interface for consumer electronic products. Unlike conventional connections, it transmits uncompressed digital video and audio signals on a single cable. This unit supports high-definition video output (720p,1080i) from the HDMI AV OUT terminal. To enjoy high-definition video, a high-definition compatible television is required.

I/P/B

MPEG 2, the video compression standard adopted for use with DVD-Video, codes frames using these 3 picture types.

I: Intra coded picture

This picture has the best quality and is the best to use when adjusting the picture.

P: Predictive coded picture

This picture is calculated based on past I- or P-pictures.

B: Bidirectionally-predictive coded picture

This picture is calculated by comparing past and future I- and P-pictures so it has the lowest volume of information.

JPEG (Joint Photographic Experts Group)

This is a system used for compressing/decoding color still pictures. If you select JPEG as the storage system on digital cameras, etc., the data will be compressed to 1/10–1/100 of its original size. The benefit of JPEG is less deterioration in picture quality considering the degree of compression.

Linear PCM (pulse code modulation)

These are uncompressed digital signals, similar to those found on CDs.

MP3 (MPEG Audio Layer 3)

An audio compression method that compresses audio to approximately one tenth of its size without any considerable loss of audio quality.

MPEG4

A compression system for use on mobile devices or a network, that allows highly efficient recording at a low bit rate.

Playback control (PBC)

If a Video CD has playback control, you can select scenes and information with menus.

Progressive/Interlaced

The PAL video signal standard has 576 interlaced (i) scan lines, whereas progressive scanning, called 576p, uses twice the number of scan lines. For the NTSC standard, these are called 480i and 480p respectively.

Using progressive output, you can enjoy the high-resolution video recorded on media such as DVD-Video.

Your television must be compatible to enjoy progressive video.

Sampling frequency

Sampling is the process of converting the heights of sound wave (analog signal) samples taken at set periods into digits (digital encoding).

Sampling frequency is the number of samples taken per second, so larger numbers mean more faithful reproduction of the original sound.

WMA (Windows Media™ Audio)

WMA is a compression format developed by Microsoft Corporation. It achieves the same sound quality as MP3 with a file size that is smaller than that of MP3.



AMPLIFIER SECTION

HT995

RMS Output Power: Dolby Digital Mode

Front Ch	125 W per channel (3 Ω), 1 kHz, 10 % THD
Surround Ch	125 W per channel (3 Ω), 1 kHz, 10 % THD
Center Ch	250 W per channel (6 Ω), 1 kHz, 10 % THD
Subwoofer Ch	250 W per channel (6 Ω), 100 Hz, 10 % THD
Total RMS Dolby Digital mode power	1000 W

PMPO Output Power

7500 W

DIN Output Power: Dolby Digital Mode

Front Ch	80 W per channel (3 Ω), 1 kHz, 1 % THD
Surround Ch	80 W per channel (3 Ω), 1 kHz, 1 % THD
Center Ch	75 W per channel (6 Ω), 1 kHz, 1 % THD
Subwoofer Ch	75 W per channel (6 Ω), 100 Hz, 1 % THD
Total DIN Dolby Digital mode power	470 W

HT995W

RMS Output Power: Dolby Digital Mode

Front Ch	125 W per channel (3 Ω), 1 kHz, 10 % THD
Surround Ch ^{#8}	125 W per channel (3 Ω), 1 kHz, 10 % THD
Center Ch	250 W per channel (6 Ω), 1 kHz, 10 % THD
Subwoofer Ch	250 W per channel (6 Ω), 100 Hz, 10 % THD
Total RMS Dolby Digital mode power	1000 W

DIN Output Power: Dolby Digital Mode

Front Ch	80 W per channel (3 Ω), 1 kHz, 1 % THD
Surround Ch ^{#8}	65 W per channel (3 Ω), 1 kHz, 1 % THD
Center Ch	75 W per channel (6 Ω), 1 kHz, 1 % THD
Subwoofer Ch	75 W per channel (6 Ω), 100 Hz, 1 % THD
Total DIN Dolby Digital mode power	440 W

FM/AM TUNER, TERMINALS SECTION

Preset Memory

FM 15 stations
AM/MW 15 stations

Frequency Modulation (FM)

Frequency range	87.50–108.00 MHz (50-kHz step)
Sensitivity	2.5 μV (IHF)
S/N 26 dB	2.2 μV
Antenna terminals	75 Ω (unbalanced)

Amplitude Modulation (AM/MW)

Frequency range	522–1629 kHz (9-kHz step)
	520–1630 kHz (10-kHz step)
	522–1629 kHz (9-kHz step)
AM Sensitivity S/N 20 dB at 999 kHz	560 μV/m

Digital audio input HT995W

Optical digital input	Optical terminal (1 system)
Sampling frequency	32 kHz, 44.1 kHz, 48 kHz

Phone jack

Terminal	Stereo, 3.5 mm jack
----------	---------------------

Mic jack HT995

Sensitivity	0.7 mV, 1.2 kΩ
Terminal	Mono, 6.3 mm jack (1 system)

Music Port (Front)

Sensitivity	100 mV, 15 kΩ
Terminal	Stereo, 3.5 mm jack

DISC SECTION

Discs played (8 cm or 12 cm)

- DVD (DVD-Video, DVD-Audio, DivX[®]1.2)
 - DVD-RAM (DVD-VR, MP3^{#2,6}, JPEG^{#2,3}, MPEG4^{#2,4}, DivX^{#1,2})
 - DVD-R (DVD-Video, DVD-VR, MP3^{#2,6}, JPEG^{#2,3}, MPEG4^{#2,4}, DivX^{#1,2})
 - DVD-R DL (DVD-Video, DVD-VR)
 - DVD-RW (DVD-Video, DVD-VR, MP3^{#2,6}, JPEG^{#2,3}, MPEG4^{#2,4}, DivX^{#1,2})
 - +R/+RW (Video)
 - +R DL (Video)
 - CD, CD-R/RW [CD-DA, Video CD, SVCD^{#5}, MP3^{#2,6}, WMA^{#2,7}, JPEG^{#2,3}, MPEG4^{#2,4}, DivX^{#1,2}, HighMAT Level 2 (Audio and Image)]
- ^{#1} Plays all versions of DivX[®] video (including DivX[®]6) with standard playback of DivX[®] media files. Certified to the DivX Home Theater Profile.
GMC (Global Motion Compensation) is not supported.
- ^{#2} The total combined maximum number of recognizable audio, picture and video contents and groups: 4000 audio, picture and video contents and 400 groups.
- ^{#3} Exif Ver 2.1 JPEG Baseline files
Picture resolution: between 160×120 and 6144×4096 pixels (Sub sampling is 4:0:0, 4:2:0, 4:2:2 or 4:4:4). Extremely long and narrow pictures may not be displayed.
- ^{#4} MPEG4 data recorded with Panasonic SD multi cameras or DVD video recorders
Conforming to SD VIDEO specifications (ASF standard)/MPEG4 (Simple Profile) video system/G.726 audio system
- ^{#5} Conforming to IEC62107
- ^{#6} MPEG-1 Layer 3, MPEG-2 Layer 3
- ^{#7} Windows Media Audio Ver.9.0 L3
Not compatible with Multiple Bit Rate (MBR)

Pick up

Wavelength (DVD/CD)	662/785 nm
Laser power (DVD/CD)	CLASS 1/CLASS 1M

Audio output (Disc)

Number of channels	5.1ch (FL, FR, C, SL, SR, SW)
--------------------	-------------------------------



VIDEO SECTION

Video system	PAL625/50, PAL525/60, NTSC
Composite video output	
Output level	1 Vp-p (75 Ω)
Terminal	Pin jack (1 system)
S-video output	
Y output level	1 Vp-p (75 Ω)
C output level	PAL: 0.3 Vp-p (75 Ω) NTSC: 0.286 Vp-p (75 Ω)
Terminal	S terminal (1 system)
Component video output (NTSC: 480p/480i, PAL: 576p/576i)	
Y output level	1 Vp-p (75 Ω)
P _B output level	0.7 Vp-p (75 Ω)
P _R output level	0.7 Vp-p (75 Ω)
Terminal	Pin jack (Y: green, P _B : blue, P _R : red) (1 system)
HDMI AV output	
Terminal	19-pin type A connector HDMI Ver.1.2a (EDID Ver.1.3)

SPEAKER SECTION

HT995

Front speakers SB-FS995

Speaker box	
Type	2 way, 2 speaker system (Bass reflex)
Speaker unit(s)	Impedance 3 Ω
1. Woofer	6.5 cm Cone type
2. Tweeter	6 cm Cone type
Input power (IEC)	125 W ^{*9} (Max)
Output sound pressure	81 dB/W (1.0 m)
Cross over frequency	7 kHz
Frequency range	82 Hz–30 kHz (–16 dB) 96 Hz–25 kHz (–10 dB)
Dimensions (W×H×D)	110 mm×1000 mm×81 mm
Mass	2.4 kg
Full assembly with Stand Base	
Dimensions (W×H×D) (Max)	258 mm×1350 mm×269 mm
Dimensions (W×H×D) (Min)	258 mm×1100 mm×269 mm
Mass	5.1 kg

Surround speakers SB-FS996

Speaker box	
Type	1 way, 1 speaker system (Bass reflex)
Speaker unit(s)	Impedance 3 Ω
Full range	6.5 cm Cone type
Input power (IEC)	125 W ^{*9} (Max)
Output sound pressure	80 dB/W (1.0 m)
Frequency range	87 Hz–25 kHz (–16 dB) 98 Hz–22 kHz (–10 dB)
Dimensions (W×H×D)	110 mm×1000 mm×81 mm
Mass	1.9 kg
Full assembly with Stand Base	
Dimensions (W×H×D) (Max)	258 mm×1350 mm×269 mm
Dimensions (W×H×D) (Min)	258 mm×1100 mm×269 mm
Mass	4.6 kg

Center speaker SB-PC995

Type	2 way, 2 speaker system (Bass reflex)
Speaker unit(s)	Impedance 6 Ω
1. Full range	6.5 cm Cone type
2. Full range	6.5 cm Cone type
Input power (IEC)	250 W ^{*9} (Max)
Output sound pressure	83 dB/W (1.0 m)
Cross over frequency	5 kHz
Frequency range	105 Hz–25 kHz (–16 dB) 125 Hz–22 kHz (–10 dB)
Dimensions (W×H×D)	320 mm×94 mm×97 mm
Mass	1.3 kg

Subwoofer SB-W995

Type	1 way, 1 speaker system (Bass reflex)
Speaker unit(s)	Impedance 6 Ω
Woofer	17 cm Cone type
Input power (IEC)	250 W (Max)
Output sound pressure	81 dB/W (1.0 m)
Frequency range	29 Hz–160 Hz (–16 dB) 34 Hz–135 Hz (–10 dB)
Dimensions (W×H×D)	235 mm×448 mm×397 mm
Mass	6.6 kg

HT995W

Front speakers SB-FS990

Type	2 way, 2 speaker system (Bass reflex)
Speaker unit(s)	Impedance 3 Ω
1. Woofer	6.5 cm Cone type
2. Tweeter	6 cm Cone type
Input power (IEC)	125 W ^{*9} (Max)
Output sound pressure	81 dB/W (1.0 m)
Cross over frequency	7 kHz
Frequency range	82 Hz–30 kHz (–16 dB) 96 Hz–25 kHz (–10 dB)
Dimensions (W×H×D)	252 mm×1123 mm×234 mm
Mass	3.7 kg

Surround speakers SB-FS540

Type	1 way, 1 speaker system (Bass reflex)
Speaker unit(s)	Impedance 3 Ω
Full range	6.5 cm Cone type
Input power (IEC)	125 W ^{*9} (Max)
Output sound pressure	80 dB/W (1.0 m)
Frequency range	87 Hz–25 kHz (–16 dB) 98 Hz–22 kHz (–10 dB)
Dimensions (W×H×D)	252 mm×1123 mm×234 mm
Mass	3.7 kg

Center speaker SB-PC895

Type	2 way, 2 speaker system (Bass reflex)
Speaker unit(s)	Impedance 6 Ω
1. Full range	6.5 cm Cone type
2. Full range	6.5 cm Cone type
Input power (IEC)	250 W ^{*9} (Max)
Output sound pressure	83 dB/W (1.0 m)
Cross over frequency	5 kHz
Frequency range	105 Hz–25 kHz (–16 dB) 125 Hz–22 kHz (–10 dB)
Dimensions (W×H×D)	270 mm×92 mm×95.4 mm
Mass	1.25 kg

Subwoofer SB-W895

Type	1 way, 1 speaker system (Bass reflex)
Speaker unit(s)	Impedance 6 Ω
Woofer	16 cm Cone type
Input power (IEC)	250 W (Max)
Output sound pressure	80 dB/W (1.0 m)
Frequency range	32 Hz–220 Hz (–16 dB) 38 Hz–180 Hz (–10 dB)
Dimensions (W×H×D)	183 mm×396 mm×267 mm
Mass	4 kg

(Continued on next page)



GENERAL

Power supply		
HT995		AC 110–127 V, 220–240 V, 50/60 Hz
HT995W		AC 230–240 V, 50 Hz
Power consumption		
HT995 Main unit		120 W
HT995W Main unit		115 W
Dimensions (W×H×D)		430 mm×60 mm×354 mm
Mass	Main unit	3.35 kg
Operating temperature range		+5 °C to +35 °C
Operating humidity range		5 % to 90 % RH (no condensation)

Power consumption in standby mode	
HT995	approx. 0.65 W
HT995W	approx. 0.5 W

HT995W

WIRELESS TRANSMITTER AND RECEIVER

Power supply			AC 230–240 V, 50 Hz
Power consumption			
	Tx (SH-FX80T)		0.85 W
	Rx (SE-FX61)		30 W
Dimensions (W×H×D)	Tx (SH-FX80T)	97 mm×47.5 mm×8.5 mm	
	Rx (SE-FX61)	89 mm×189 mm×180 mm	
Mass			
	Tx (SH-FX80T)		0.03 kg
	Rx (SE-FX61)		0.7 kg
Wireless module	Frequency range		2.402–2.480 GHz
	No. of channels		79
	RF Output Power		19 dBm (Max)
Operating temperature range			+5 °C to +35 °C
Operating humidity range			5 % to 90 % RH (no condensation)

Power consumption in standby mode	approx. 0.5 W
--	---------------

^{#8} Power output of the wireless receiver amplifier SE-FX61

^{#9} Rating with low-cut filter equipped amplifier

Note

- Specifications are subject to change without notice.
Mass and dimensions are approximate.
- Total harmonic distortion is measured by a digital spectrum analyzer.



Manufactured under license from Dolby Laboratories. "Dolby", "Pro Logic" and the double-D symbol are trademarks of Dolby Laboratories.

"DTS" and "DTS Digital Surround" are registered trademarks of Digital Theater Systems, Inc.

This product incorporates copyright protection technology that is protected by method claims of certain U.S. patents and other intellectual property rights owned by Macrovision Corporation and other rights owners. Use of this copyright protection technology must be authorized by Macrovision Corporation, and is intended for home and other limited viewing uses only unless otherwise authorized by Macrovision Corporation. Reverse engineering or disassembly is prohibited.

MPEG Layer-3 audio decoding technology licensed from Fraunhofer IIS and Thomson multimedia.

Windows Media, and the Windows logo are trademarks, or registered trademarks of Microsoft Corporation in the United States and/or other countries.

WMA is a compression format developed by Microsoft Corporation. It achieves the same sound quality as MP3 with a file size that is smaller than that of MP3.



HighMAT™ and the HighMAT logo are either trademarks or registered trademarks of Microsoft Corporation in the United States and/or other countries.

 , HDCD®, High Definition Compatible Digital® and Pacific Microsonics™ are either registered trademarks or trademarks of Pacific Microsonics, Inc. in the United States and/or other countries.

HDCD system manufactured under license from Pacific Microsonics, Inc. This product is covered by one or more of the following: In the USA: 5,479,168, 5,638,074, 5,640,161, 5,808,574, 5,838,274, 5,854,600, 5,864,311, 5,872,531, and in Australia: 669114, with other patents pending.

This product is licensed under the MPEG-4 Visual patent portfolio license for the personal and non-commercial use of a consumer for (i) encoding video in compliance with the MPEG-4 Visual Standard ("MPEG-4 Video") and/or (ii) decoding MPEG-4 Video that was encoded by a consumer engaged in a personal and non-commercial activity and/or was obtained from a video provider licensed by MPEG LA to provide MPEG-4 Video. No license is granted or shall be implied for any other use. Additional information including that relating to promotional, internal and commercial uses and licensing may be obtained from MPEG LA, LLC. See <http://www.mpegla.com>.

Official DivX® Certified product.
Plays all versions of DivX® video (including DivX®6) with standard playback of DivX® media files.
DivX, DivX Certified, and associated logos are trademarks of DivX, Inc. and are used under license.



HDMI, the HDMI logo and High-Definition Multimedia Interface are trademarks or registered trademarks of HDMI Licensing LLC.

HDAVI Control™ is a trademark of Matsushita Electric Industrial Co., Ltd.



CAUTION!

THIS PRODUCT UTILIZES A LASER.
USE OF CONTROLS OR ADJUSTMENTS OR PERFORMANCE OF PROCEDURES OTHER THAN THOSE SPECIFIED HEREIN MAY RESULT IN HAZARDOUS RADIATION EXPOSURE.
DO NOT OPEN COVERS AND DO NOT REPAIR YOURSELF.
REFER SERVICING TO QUALIFIED PERSONNEL.

WARNING:

TO REDUCE THE RISK OF FIRE, ELECTRIC SHOCK OR PRODUCT DAMAGE, DO NOT EXPOSE THIS APPARATUS TO RAIN, MOISTURE, DRIPPING OR SPLASHING AND THAT NO OBJECTS FILLED WITH LIQUIDS, SUCH AS VASES, SHALL BE PLACED ON THE APPARATUS.

CAUTION!

- DO NOT INSTALL OR PLACE THIS UNIT IN A BOOKCASE, BUILT-IN CABINET OR IN ANOTHER CONFINED SPACE. ENSURE THE UNIT IS WELL VENTILATED. TO PREVENT RISK OF ELECTRIC SHOCK OR FIRE HAZARD DUE TO OVERHEATING, ENSURE THAT CURTAINS AND ANY OTHER MATERIALS DO NOT OBSTRUCT THE VENTILATION VENTS.
- DO NOT OBSTRUCT THE UNIT'S VENTILATION OPENINGS WITH NEWSPAPERS, TABLECLOTHS, CURTAINS, AND SIMILAR ITEMS.
- DO NOT PLACE SOURCES OF NAKED FLAMES, SUCH AS LIGHTED CANDLES, ON THE UNIT.
- DISPOSE OF BATTERIES IN AN ENVIRONMENTALLY FRIENDLY MANNER.

This product may receive radio interference caused by mobile telephones during use. If such interference is apparent, please increase separation between the product and the mobile telephone.

The socket outlet shall be installed near the equipment and easily accessible or the mains plug or an appliance coupler shall remain readily operable.

For Southeast Asia, Thailand, the Middle East, South Africa, Saudi Arabia and Kuwait

THIS UNIT IS INTENDED FOR USE IN TROPICAL CLIMATES.

For Australia and N.Z.

THIS UNIT IS INTENDED FOR USE IN MODERATE CLIMATES.

For Southeast Asia, Thailand, the Middle East, South Africa, Saudi Arabia and Kuwait

CAUTION:

The AC voltage is different according to the area.
Be sure to set the proper voltage in your area before use.
(For details, please refer to page 14.)

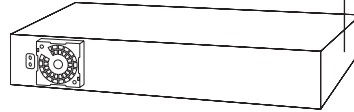

(Side of product)

CAUTION	- LASER RADIATION WHEN OPEN. DO NOT STARE INTO BEAM. FDA 21 CFR 1 Class
CAUTION	- CLASS 1M VISIBLE AND INVISIBLE LASER RADIATION WHEN OPEN. DO NOT VIEW DIRECTLY WITH OPTICAL INSTRUMENTS. IEC60825-1 +A21 Class 1M
VARNING	- KLASS 1M SYNLIG OCH OSYNLIG LASERSTRÅLNING NÄR DENNA DEL ÄR ÖPPNAD. BETRÄKTA EJ STRÅLEN DIREKT GENOM OPTISKE INSTRUMENTER.
FORSIGTIG	- SYNLIG OG USTYNLIG LASERSTRÅLING KLASS 1M. NÄR LÅGET ER ÅBENT. UNDGÅ AT SE LIGE PÅ MED OPTISKE INSTRUMENTER.
VARO!	- AVATTRESSA OLET ALTIIN LUOKAN 1M NÄKYNÄÄ JA NÄKYMÄTÖNTÄ. LASERSÄTELYÄ. ÄLÄ KATSO OPTISELLA LAITTEILLA SUORAAN SÄTEESEEN.
VORSICHT	- SICHTBARE UND UNSICHTBARE LASERSTRÄHLUNG KLASSE 1M. WENN ABDECKUNG GEÖFFNET. NICHT DIREKT MIT OPTISCHEN INSTRUMENTEN BETRACHTEN.
ATTENTION	- RAYONNEMENT LASER VISIBLE ET INVISIBLE. CLASSE 1M. EN CAS D'OUVERTURE. NE PAS REGARDER DIRECTEMENT À L'ADRE DES INSTRUMENTS D'OPTIQUE.
注意	- ここを開くと可視及び不可視レーザー光が出ます。 ビームを見たり、触れたりしないでください。
注意	- 打开时有可见及不可见激光辐射。避免直视辐射。 GB7241.1-2001/IEC 类 ROLX50075

(Inside of product)

-If you see this symbol-



Information on Disposal in other Countries outside the European Union

This symbol is only valid in the European Union.

If you wish to discard this product, please contact your local authorities or dealer and ask for the correct method of disposal.